

EDGE 29 -- EE PW

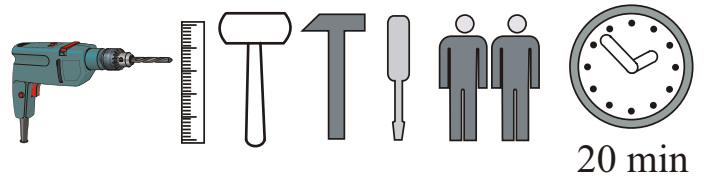

NO	Dim.			Col.-No	Qty
1	1502	200	16	1	1
2	1300	184	16	1	1

EDGE 29 -- EE PW

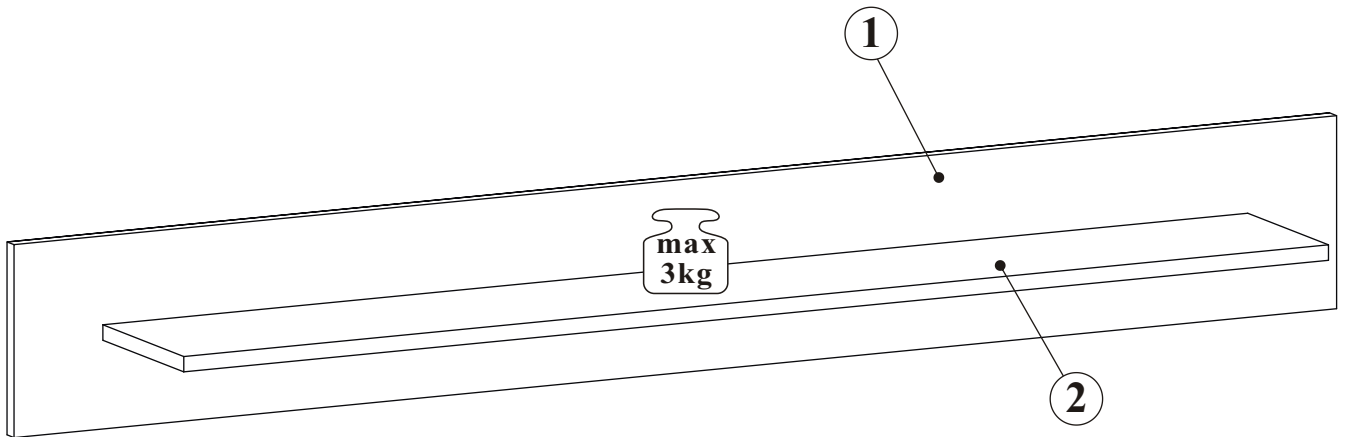
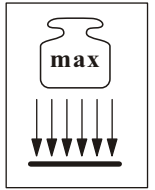
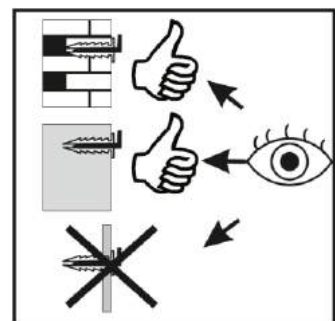
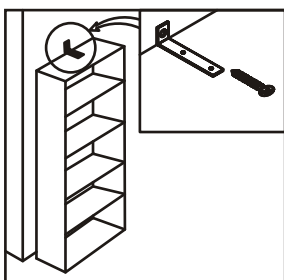
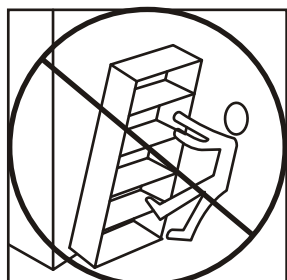
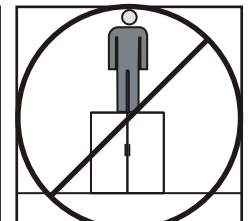
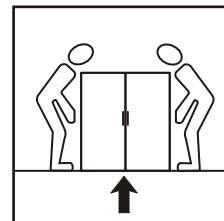
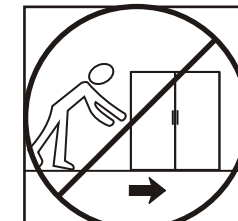
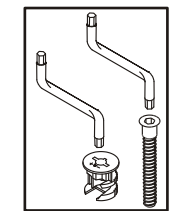
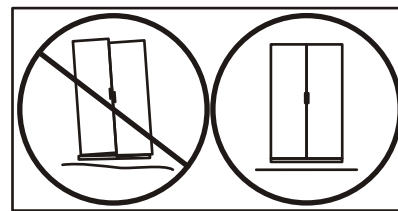
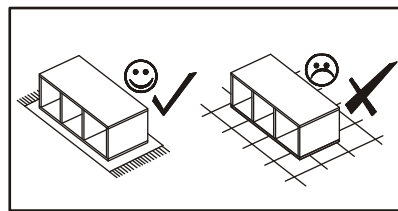
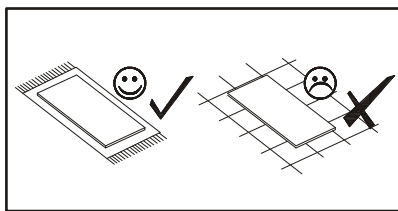
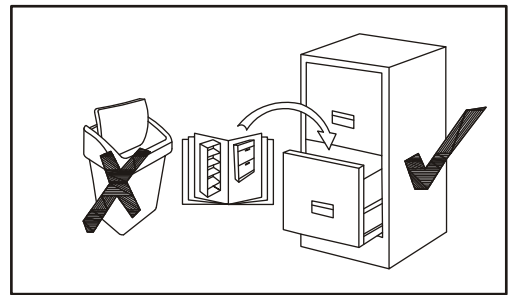
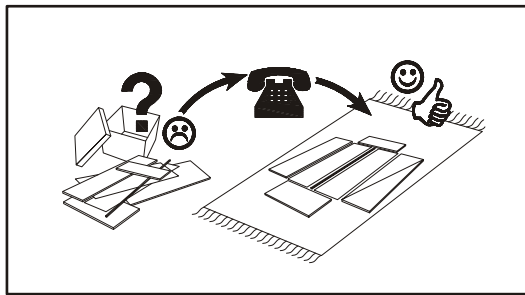
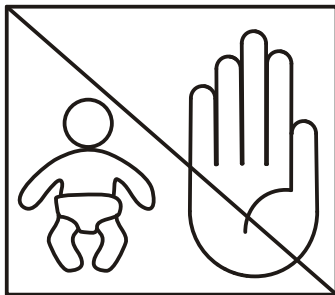
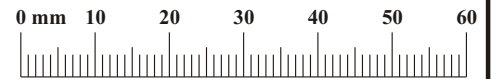
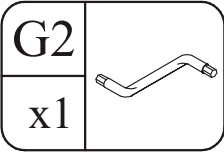
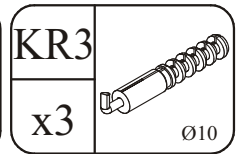
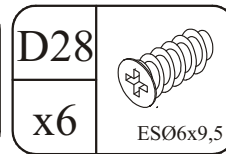
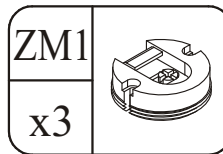
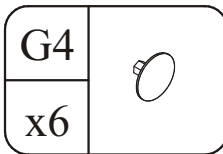
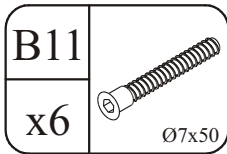
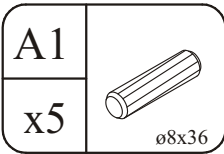

EDGE 29 -- EE PW

1

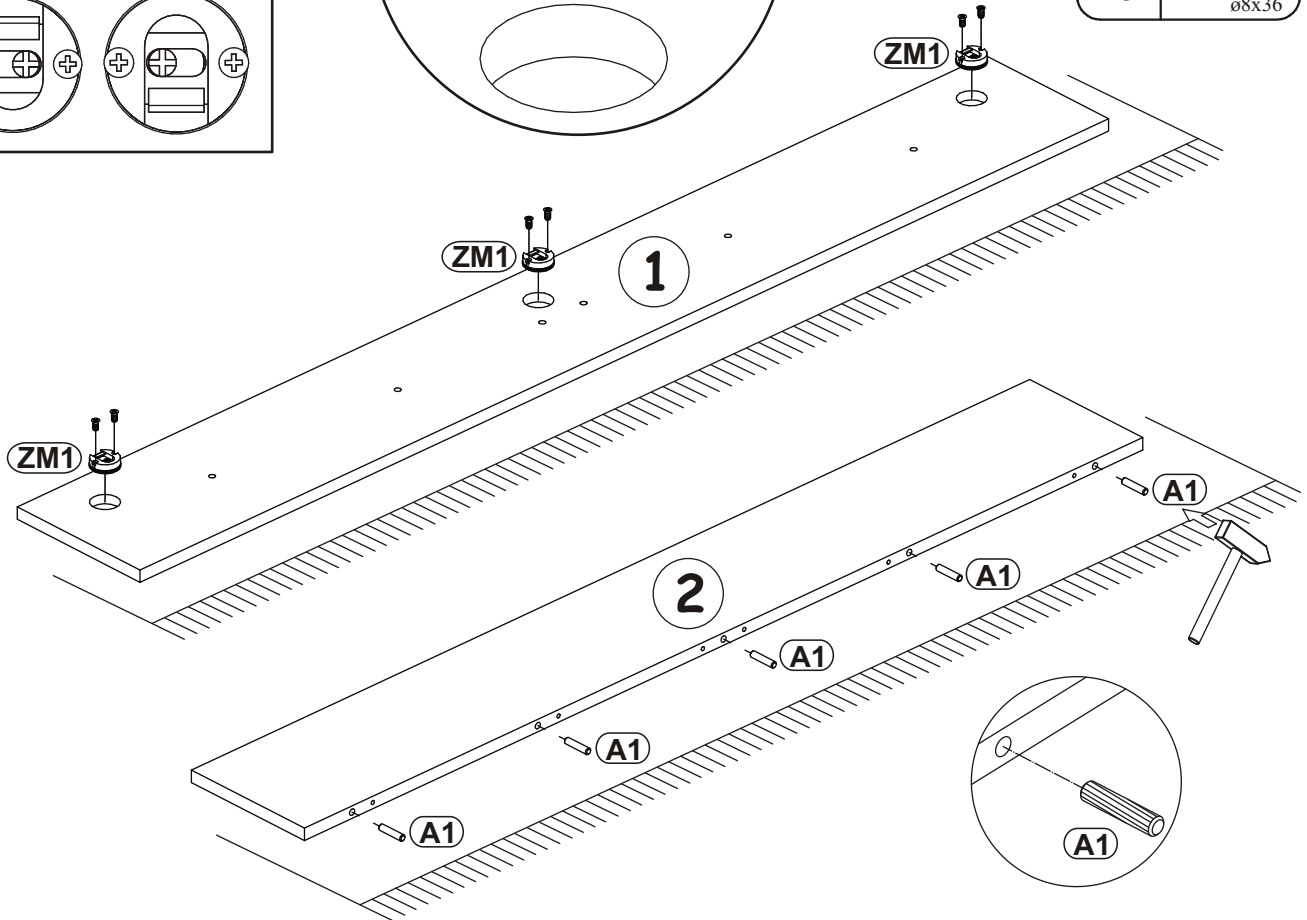
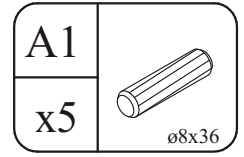
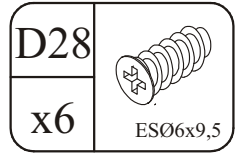
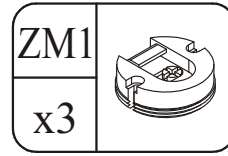
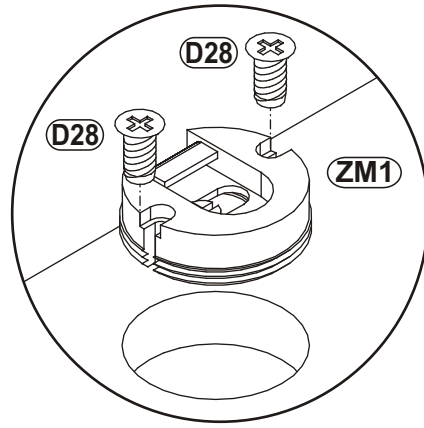
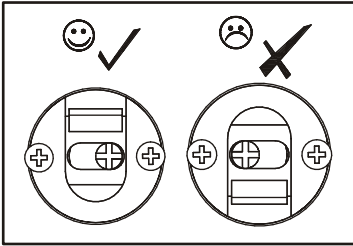

2

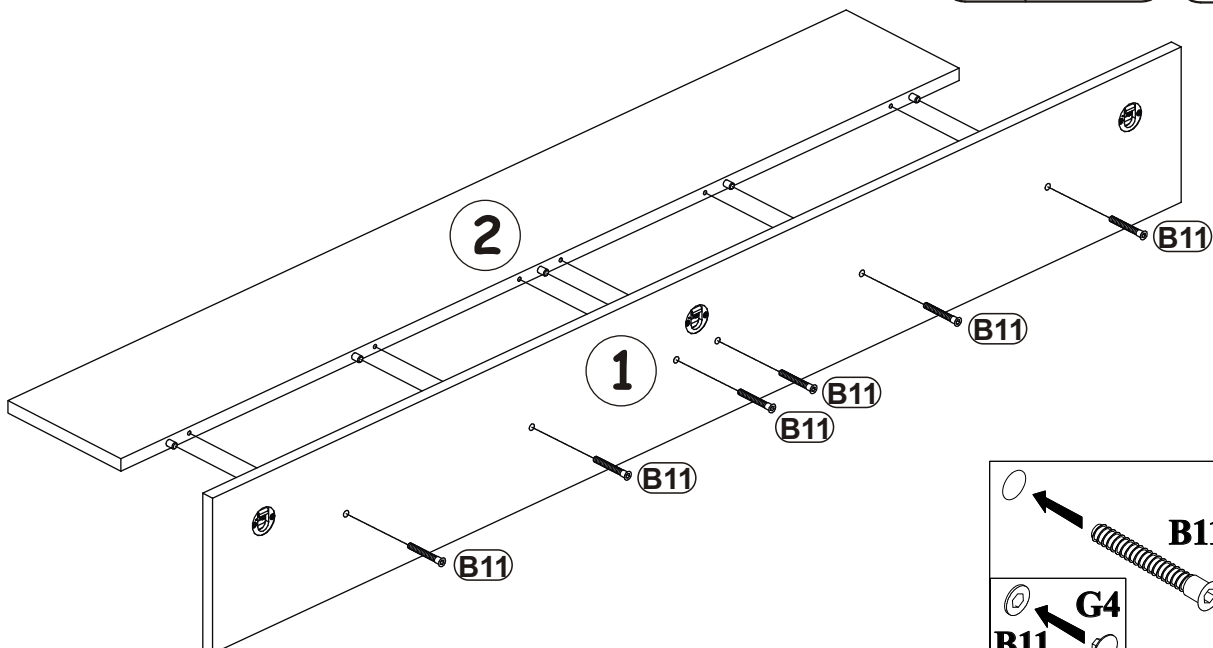
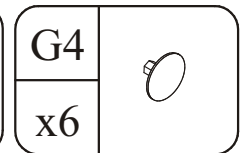
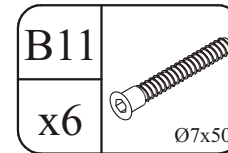

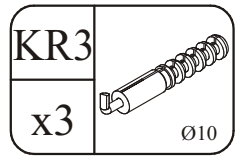

3

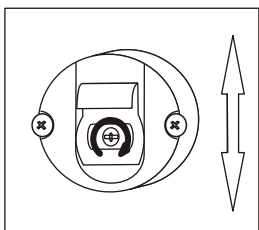
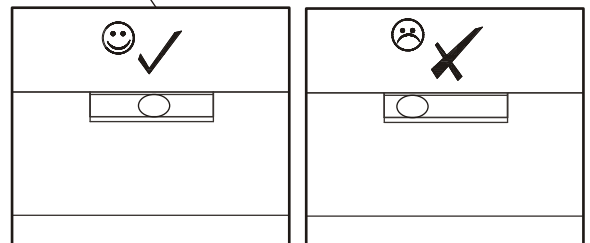
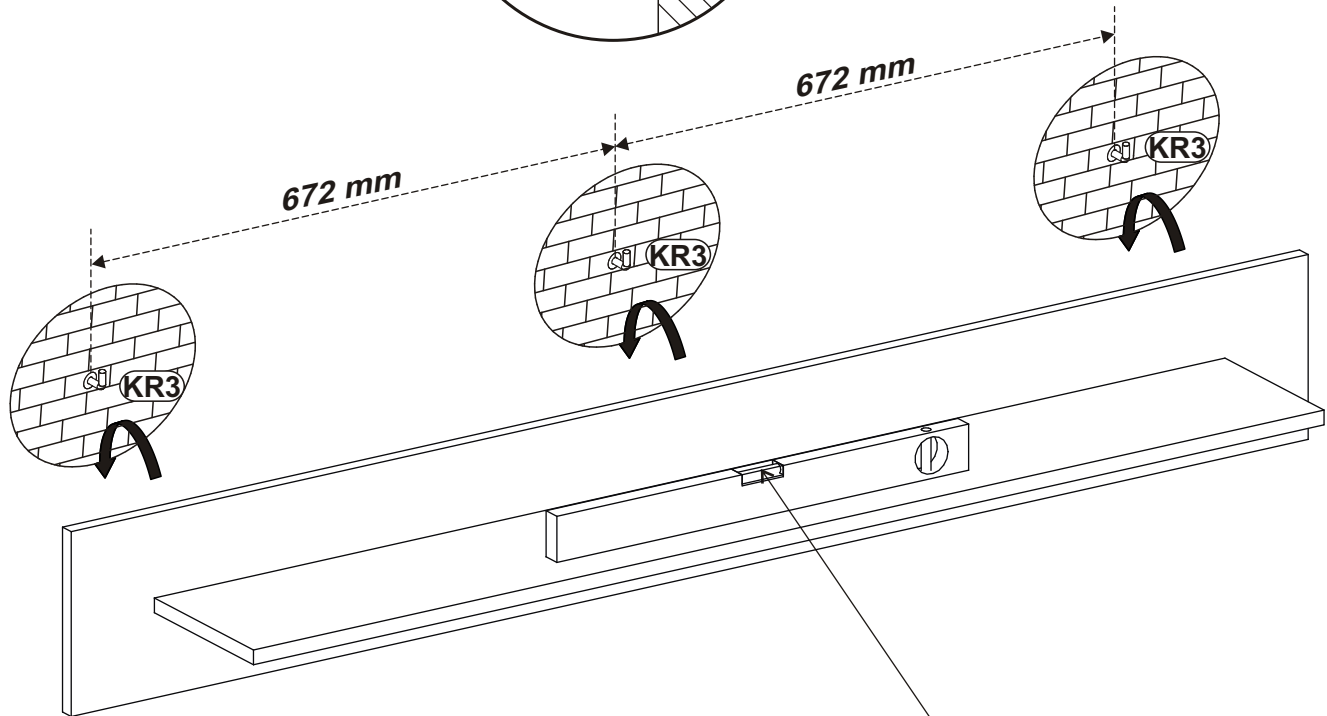
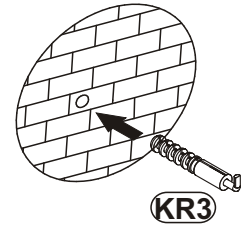
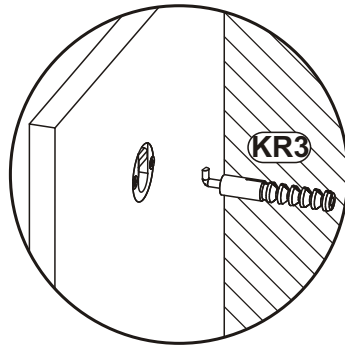
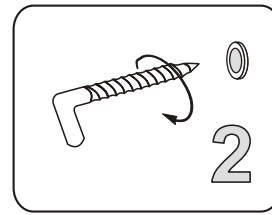
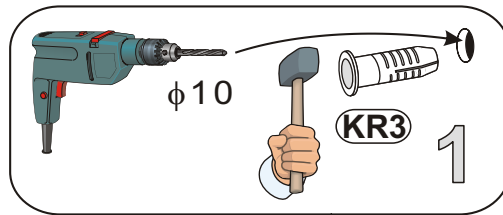
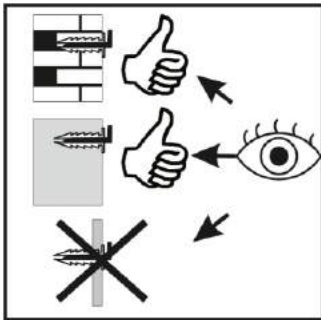

EDGE 29 -- EE RTV

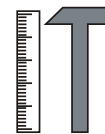
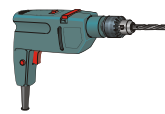
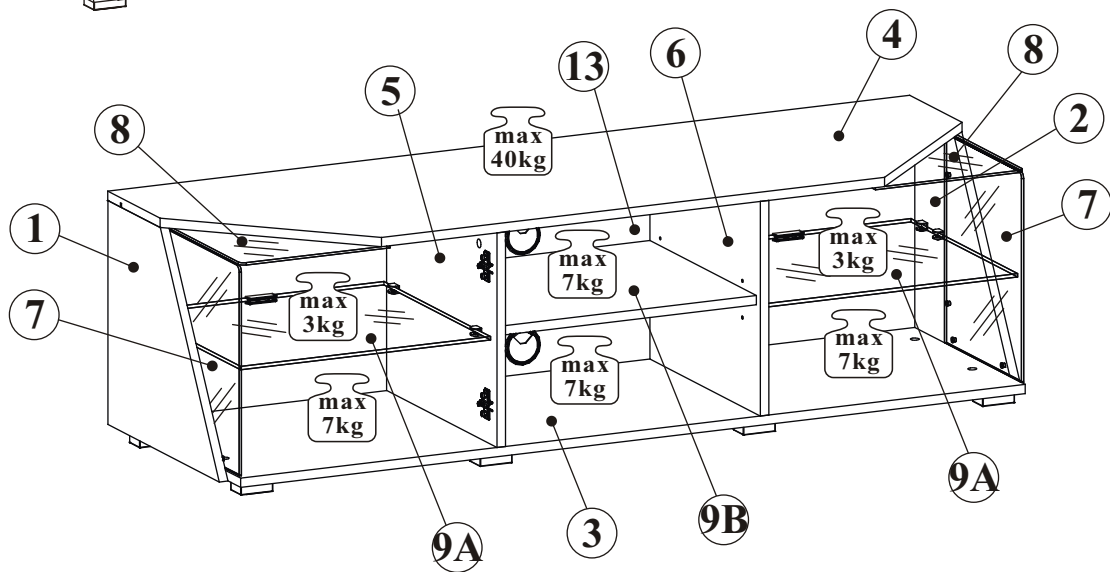
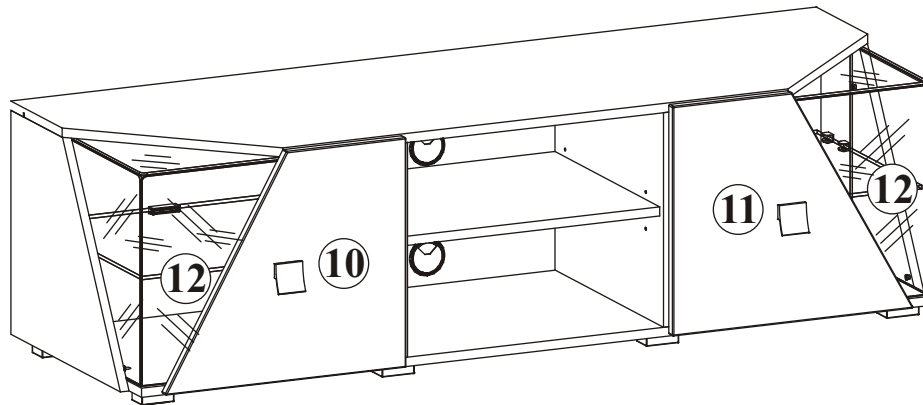
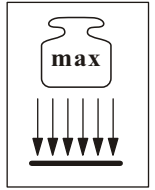







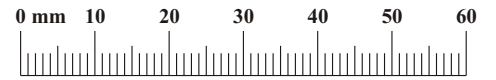

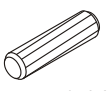
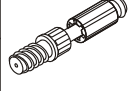



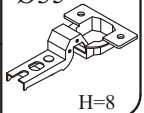
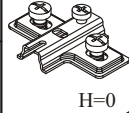

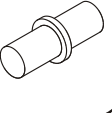
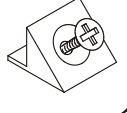
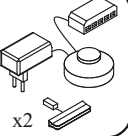
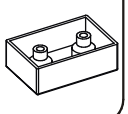
90 min

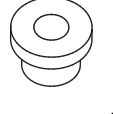
NO	Dim.			Col.-No	Qty
1	390	434	16	2	1
2	390	434	16	2	1
3	1469	484	16	1	1
4	1502	484	16	1	1
5	374	430	16	2	1
6	374	430	16	2	1
7	365	300	4	2	2
8	305	279	4	2	2
9A	468	415	6	2	2
9B	477	415	16	2	1
10	448	400	16	2	1
11	448	400	16	2	1
12	365	280	4	2	2
13	1481	385	3	1	1

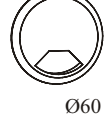
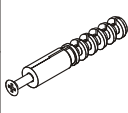
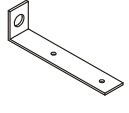
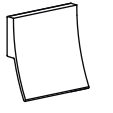
EDGE 29 -- EE RTV

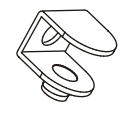

A1 x16  ø8x36	B4 x10 	B5 x10  ø15x12	G5 x10 	B11 x4  ø7x50	G4 x4 
E23 x4  Ø35 H=8	E2 x4  H=0	D10 x12  USØ3,5x13	G7 x4 	S1 x12 	LED x1  x2
ST17 x8 	UP11 x16  UPØ4x20	P2 x24 	UP13 x28  UPØ3x16	G2 x1 	G18 x2  Ø60
KR1 x2 	L1 x2 	U19 x2 	DS4 x4  WSM4x22	G31 x8 	D20 x8  ESØ6,3x9,5

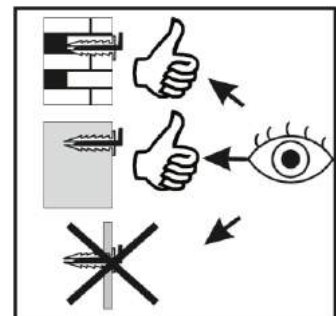
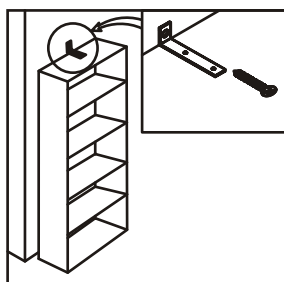
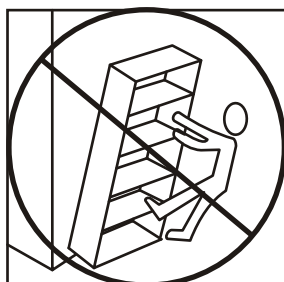
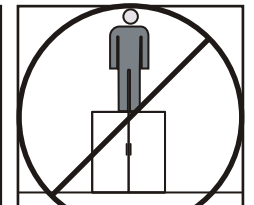
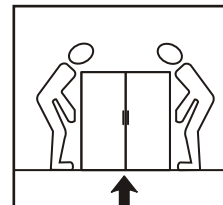
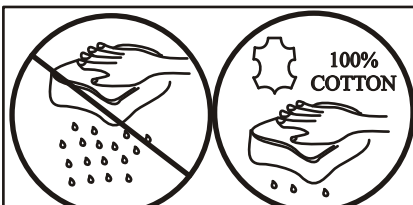
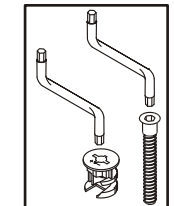
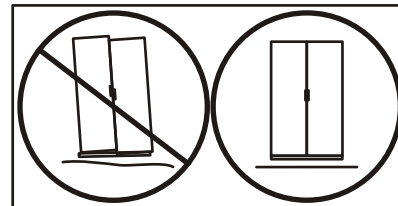
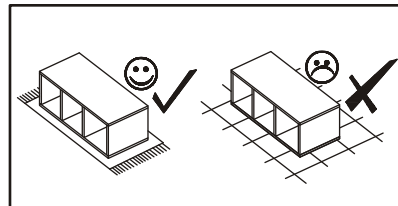
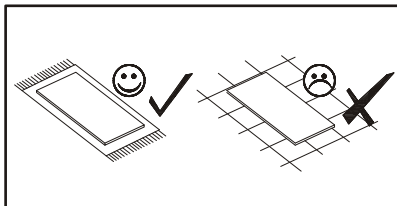
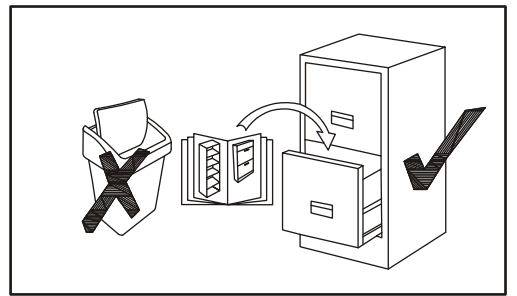
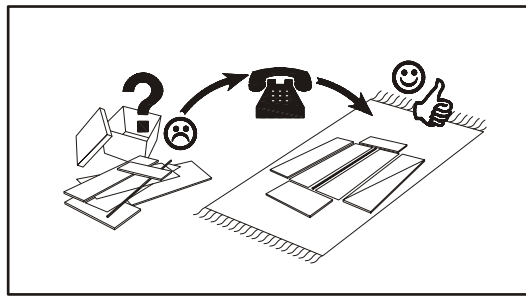
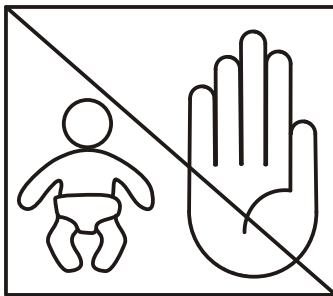

EDGE 29 -- EE RTV

1

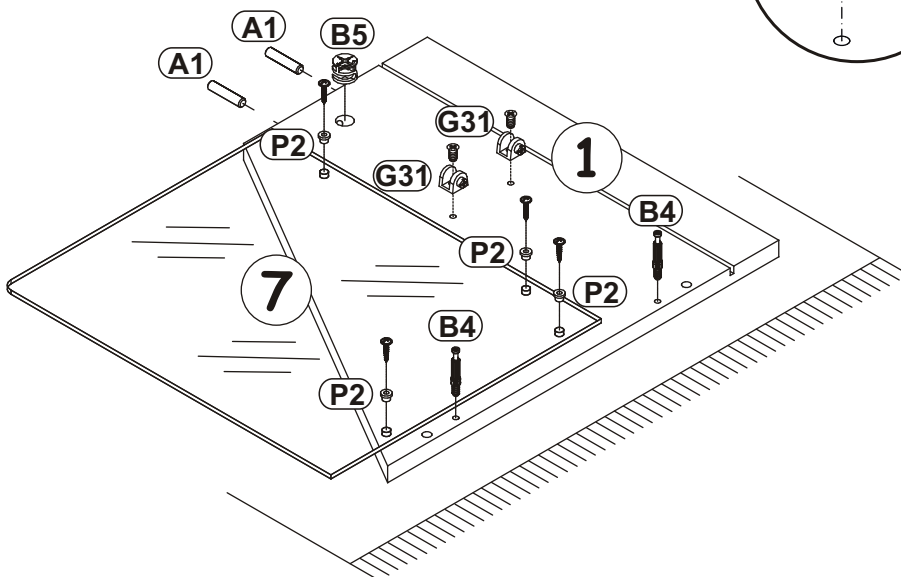
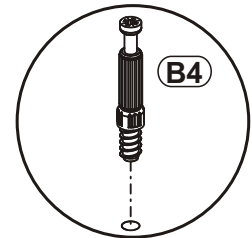
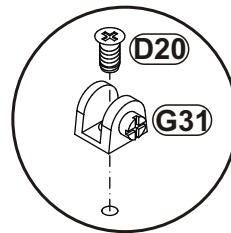
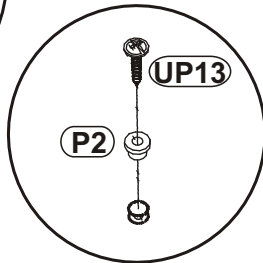
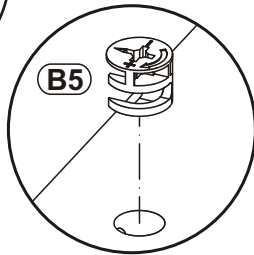
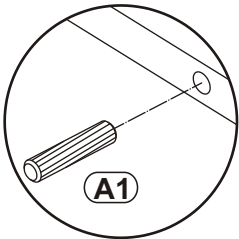
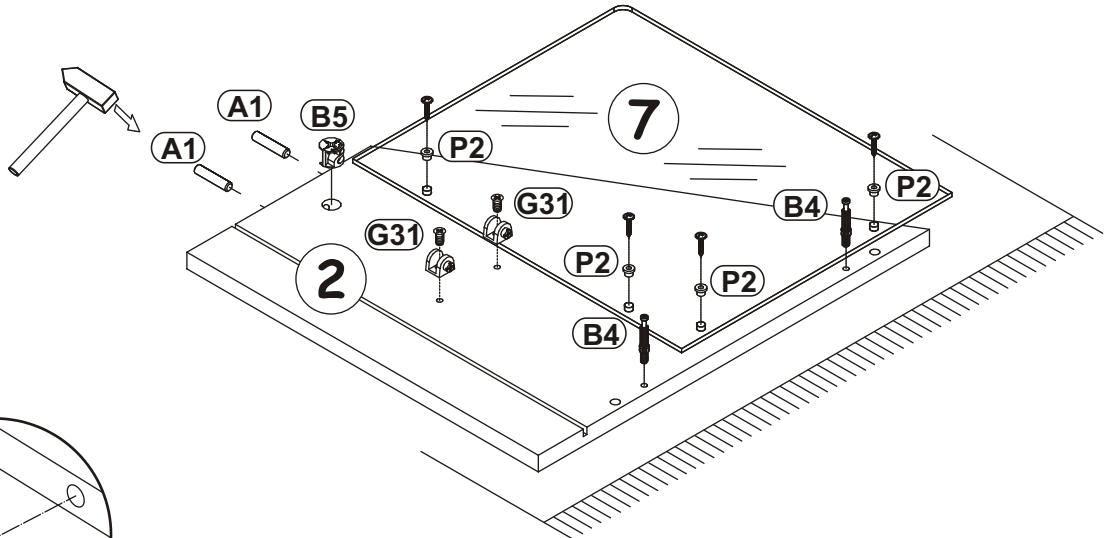
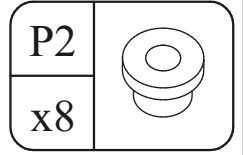
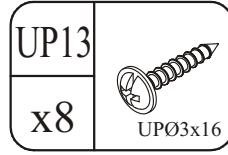
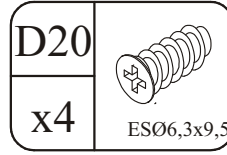
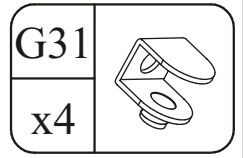
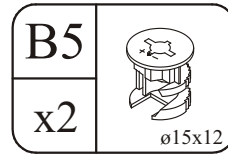
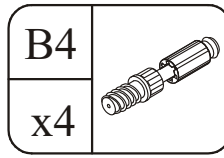
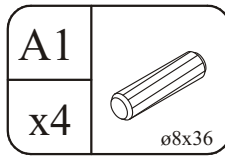

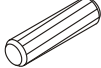

EDGE 29 -- EE RTV

2

A1	
x8	ø8x36

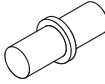
B5	
x4	ø15x12

G7	
x4	

G31	
x4	

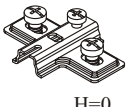
E2	
x4	H=0

D20	
x4	ESØ6,3x9,5

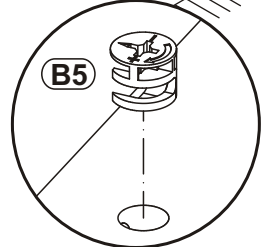
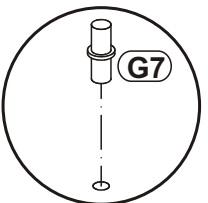
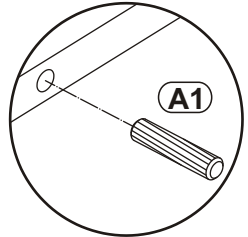
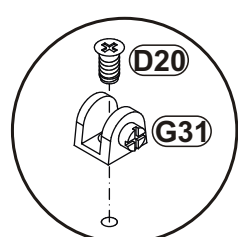
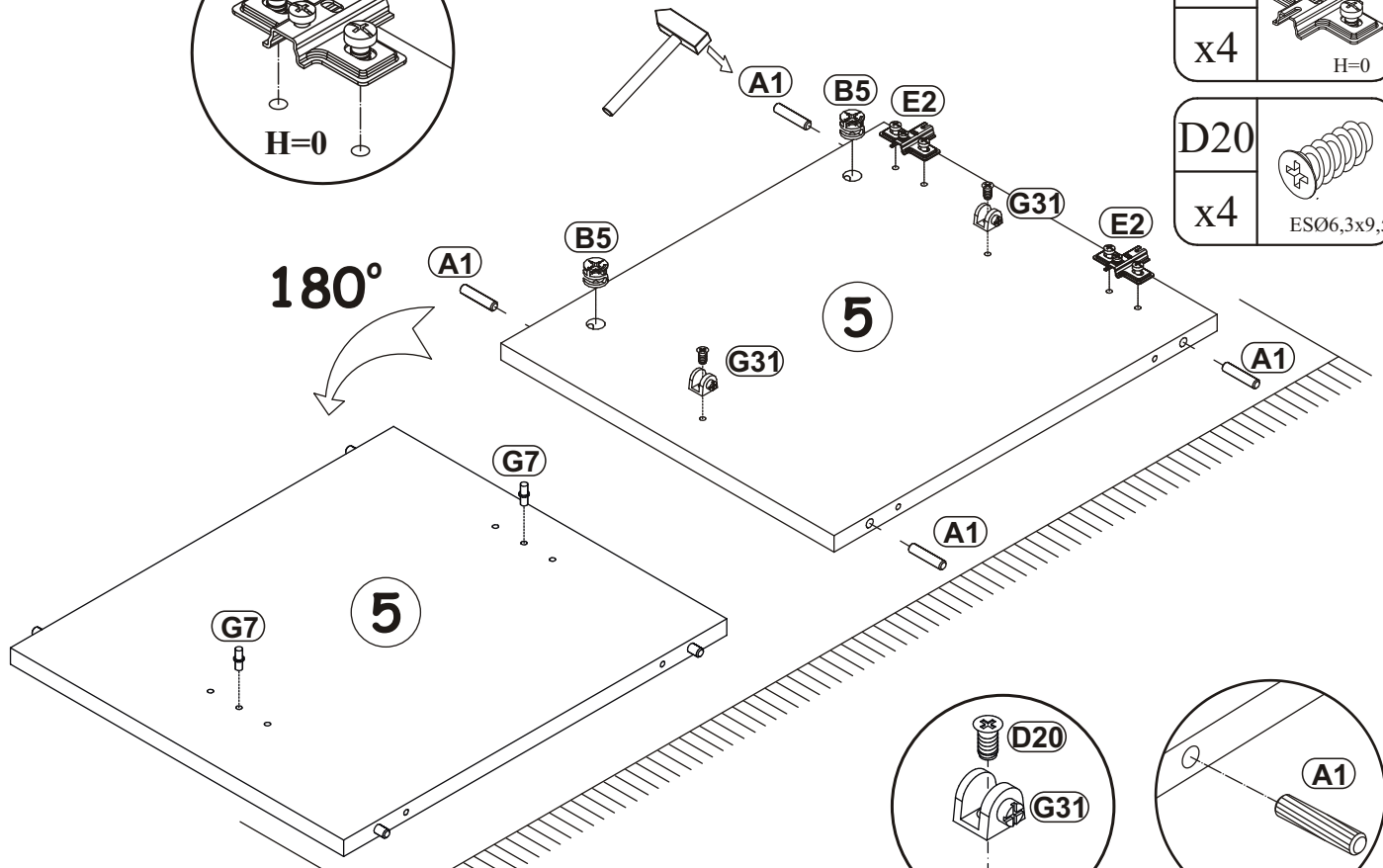
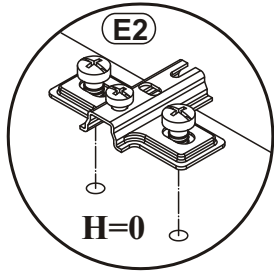

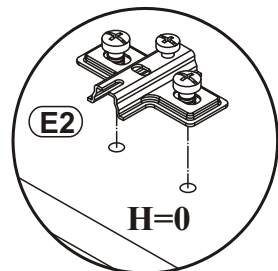
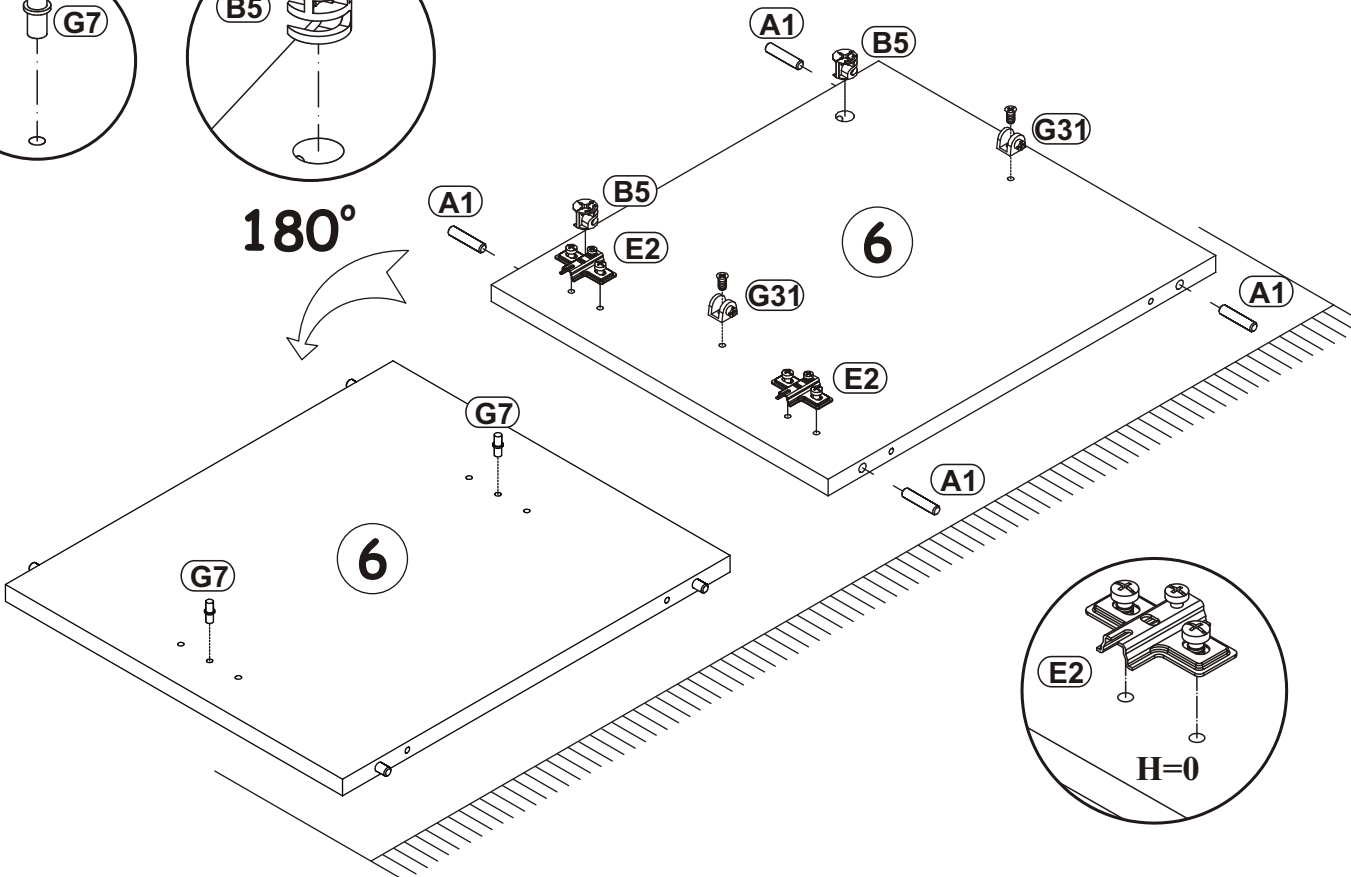

180°



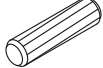

EDGE 29 -- EE RTV

3

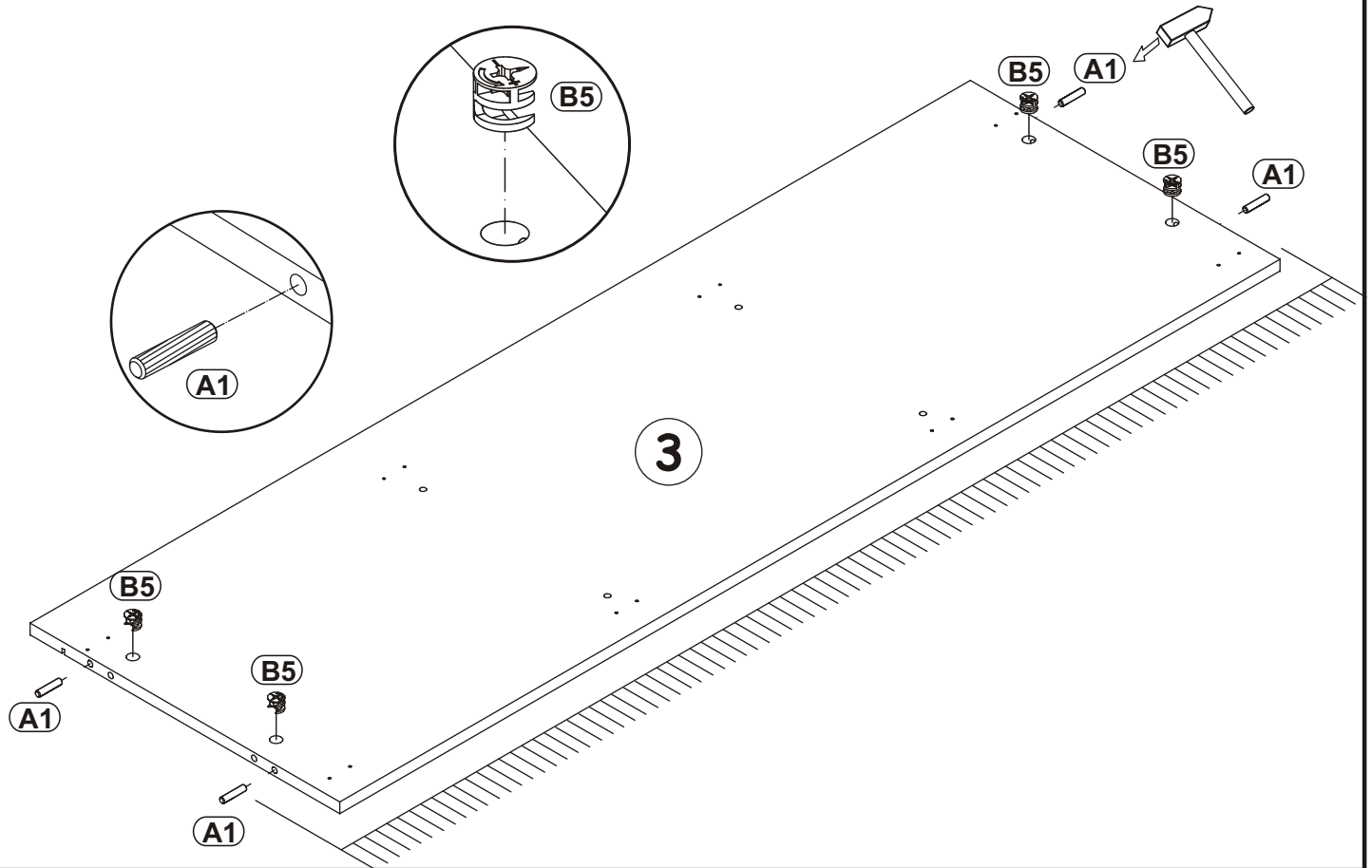
A1		B5	
x4	ø8x36	x4	ø15x12

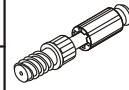
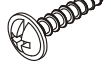

4

B4		UP13		P2	
x6		x8	UPØ3x16	x8	

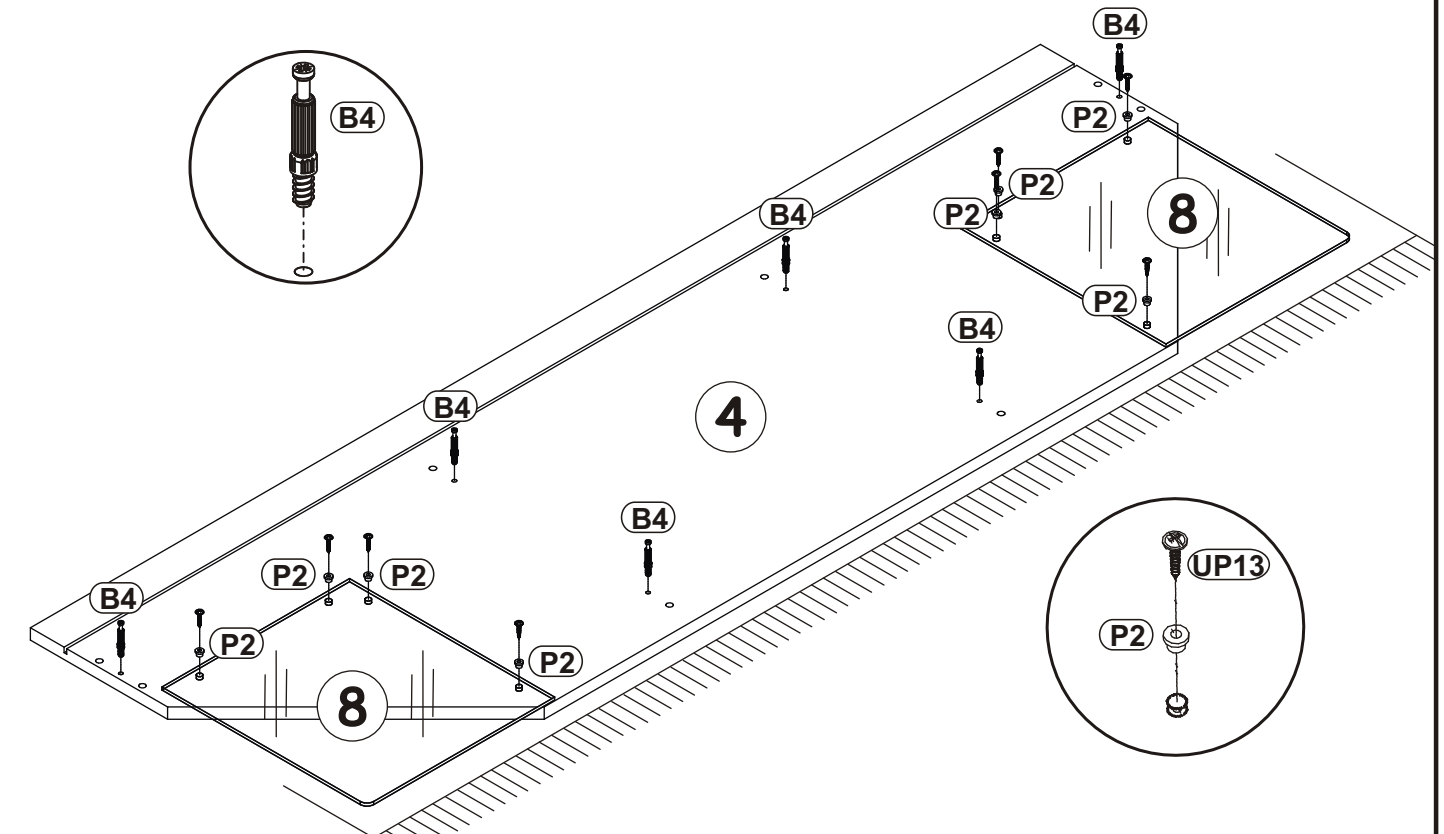

EDGE 29 -- EE RTV

5

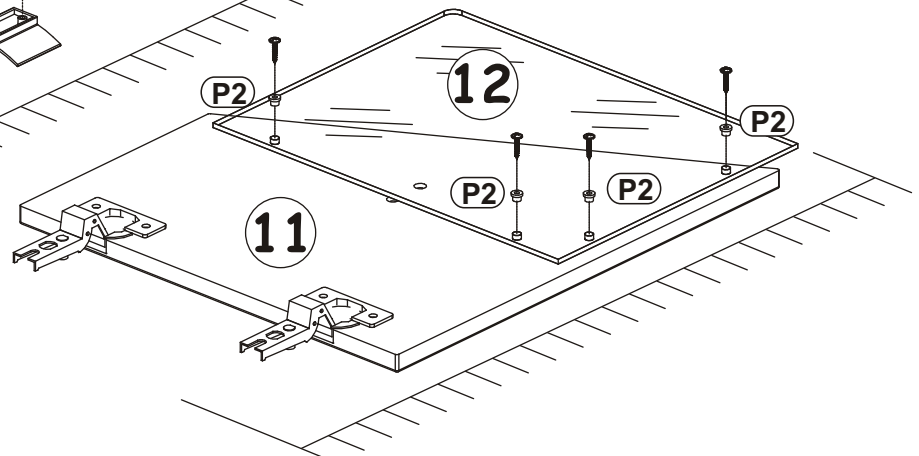
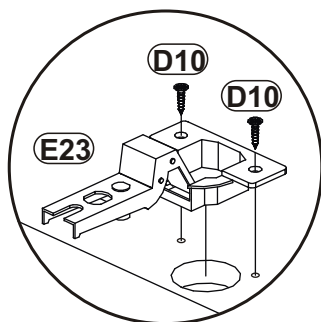
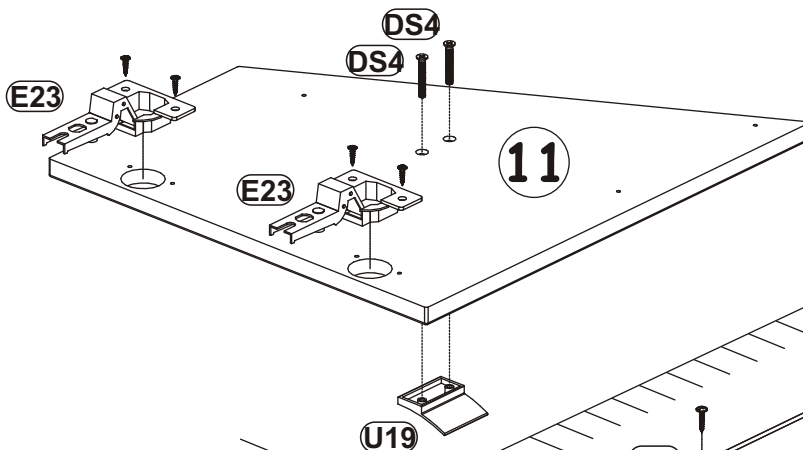
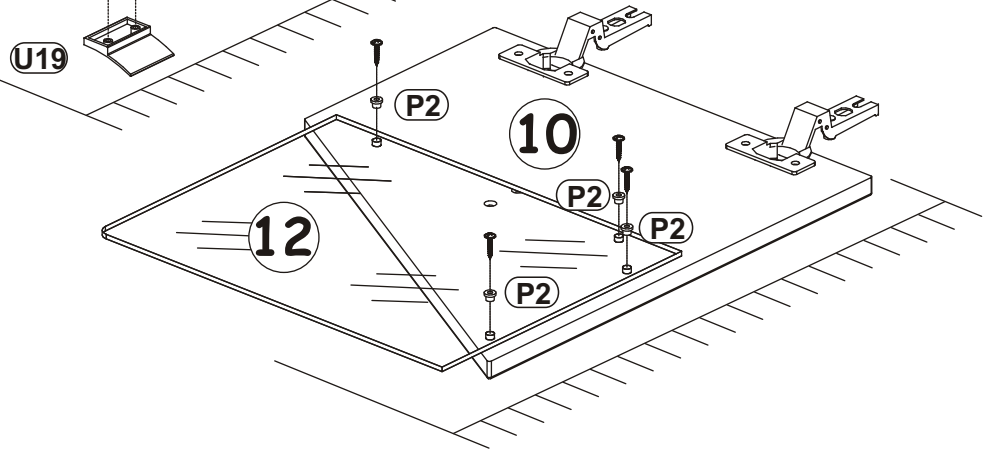
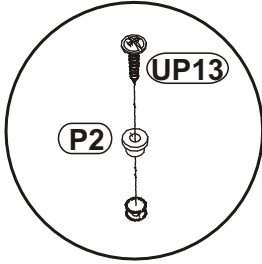
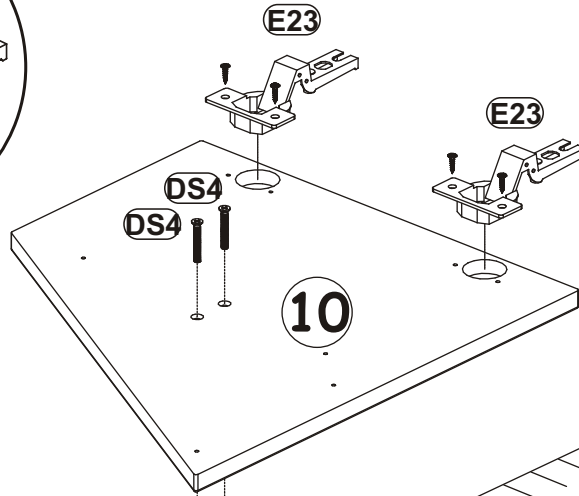
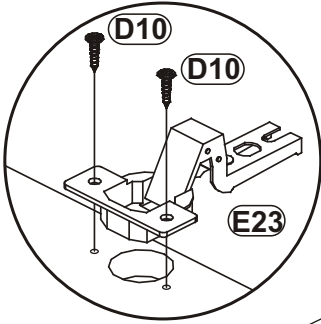
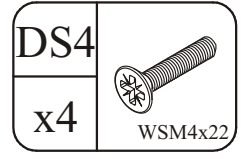
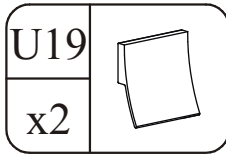
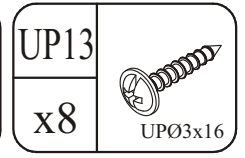
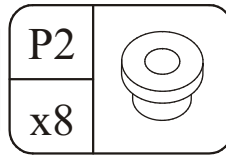
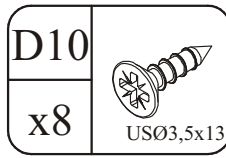
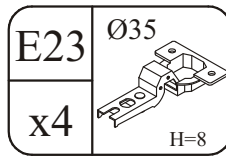

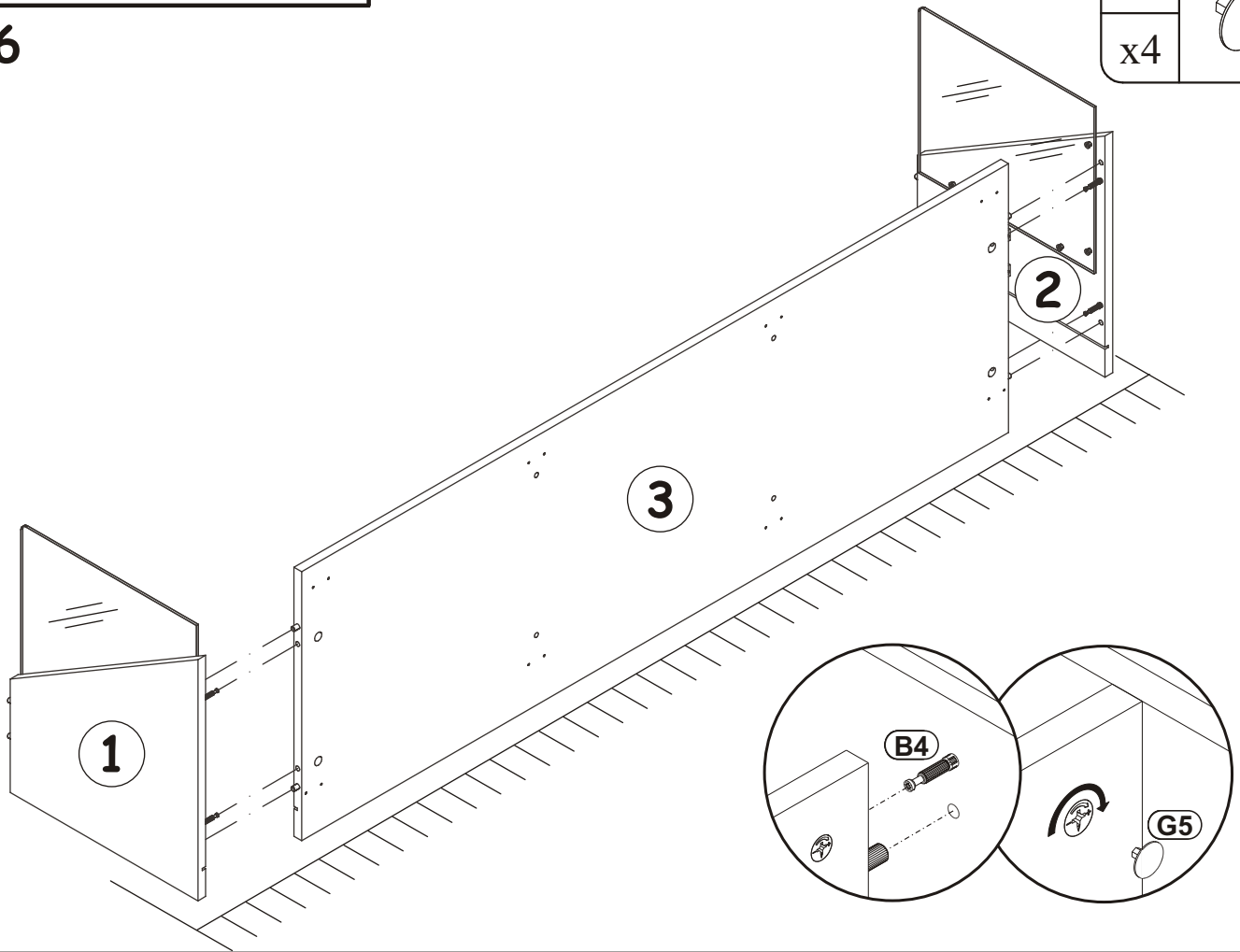

6

G5	
x4	



7

B11	
x4	Ø7x50

G4	
x4	

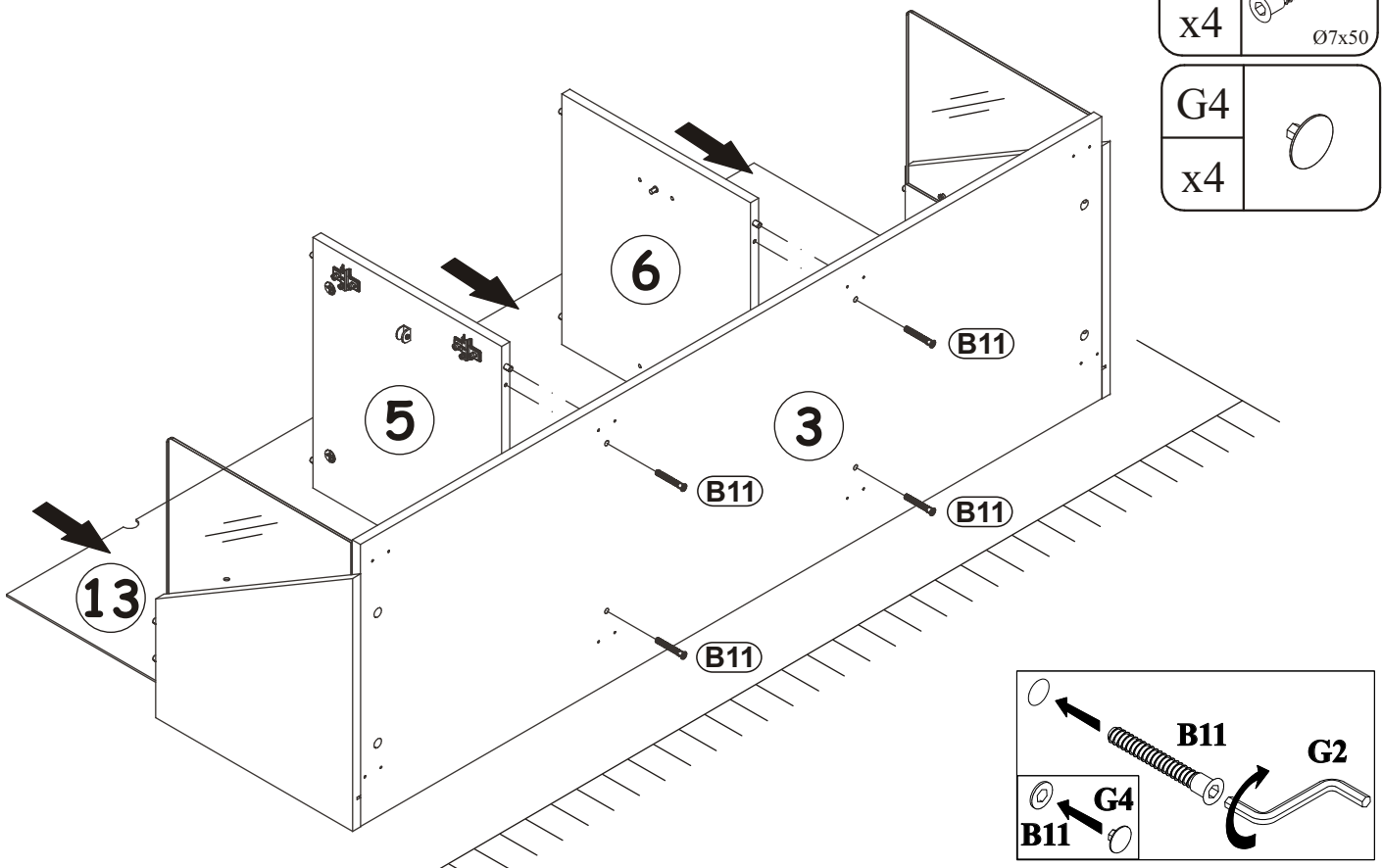

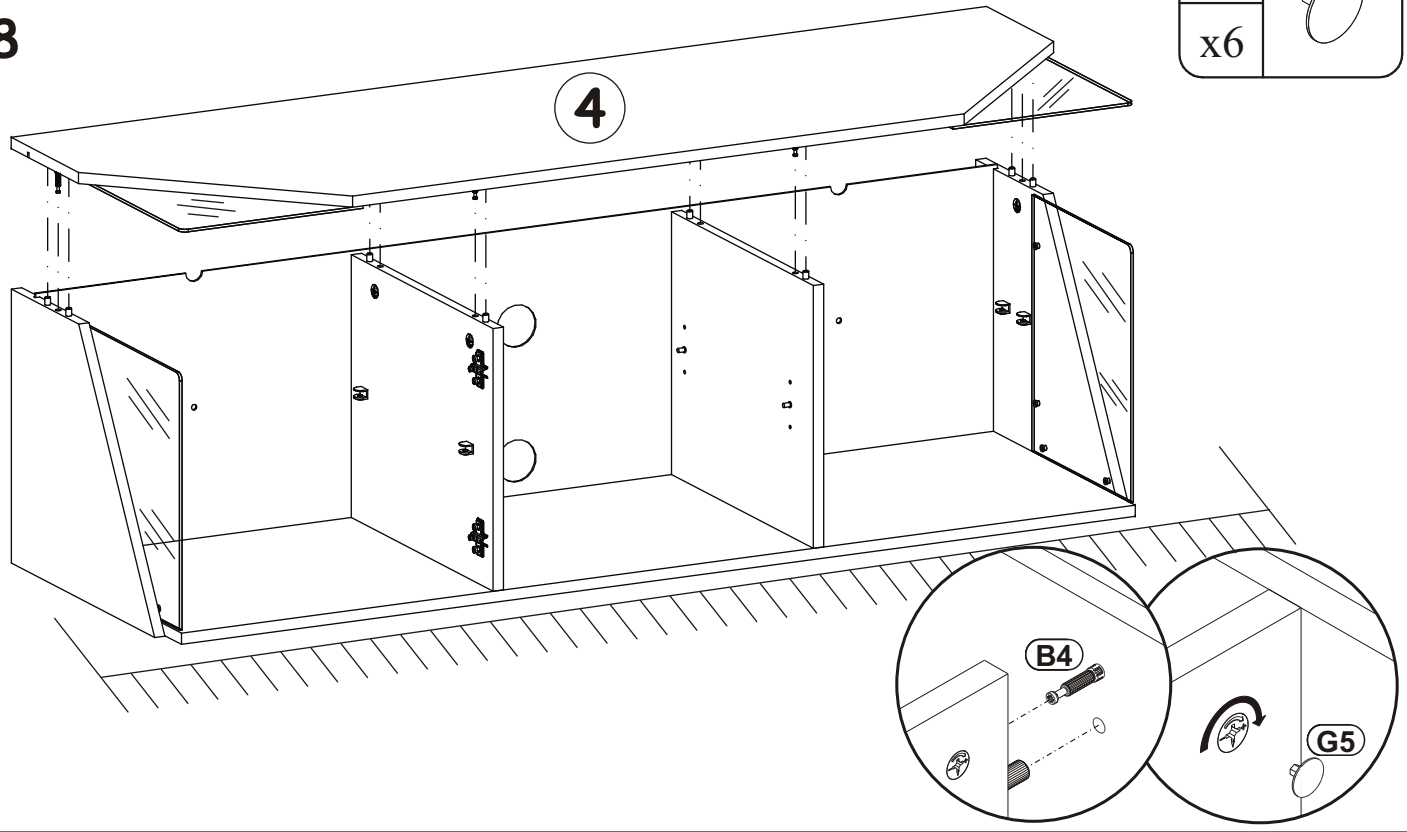

8

G5	
x6	



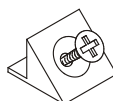
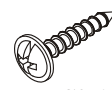
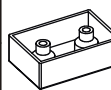

9

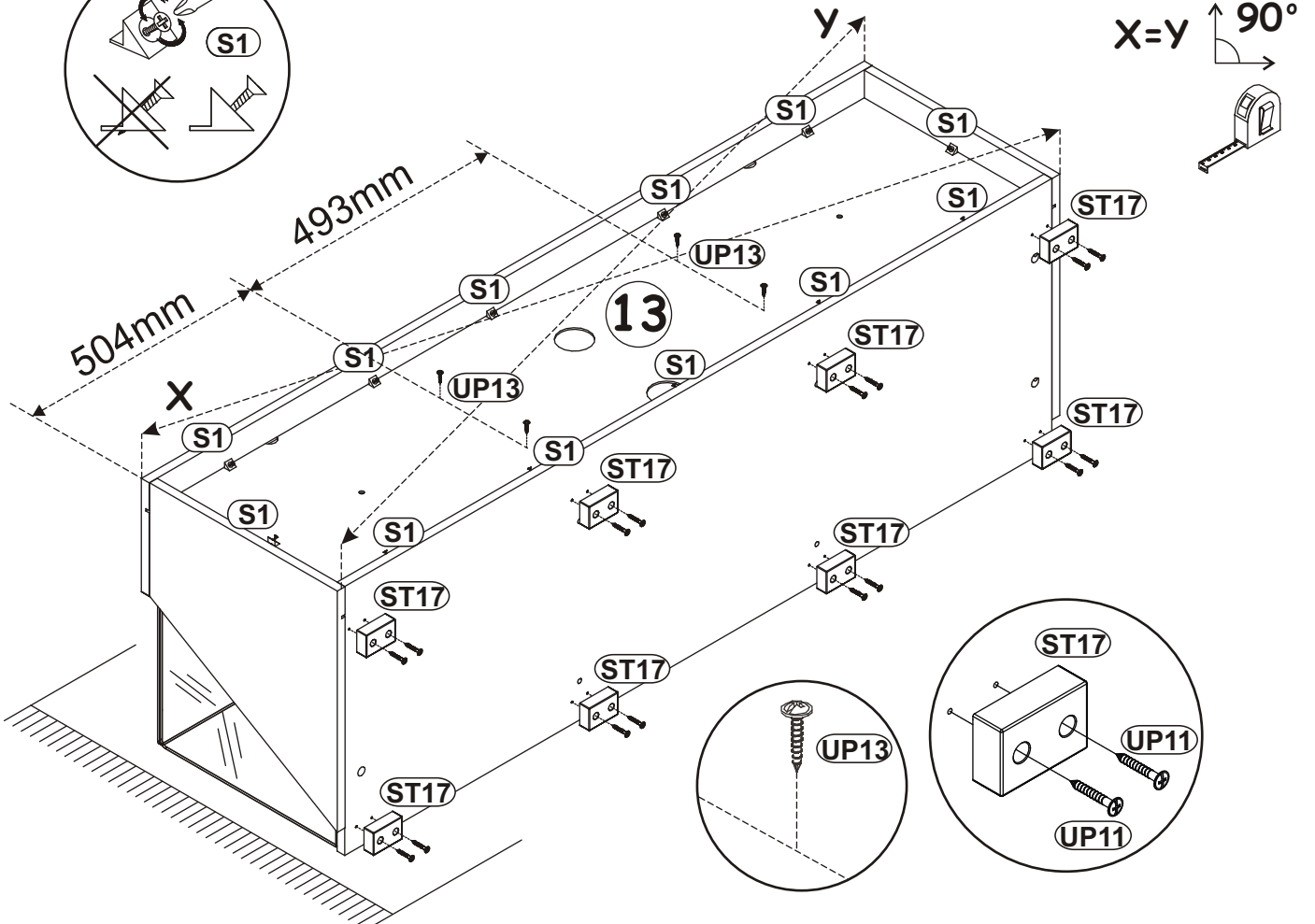
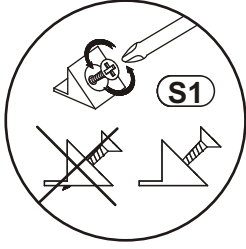
S1		UP13		ST17		UP11	
x12		x4	UPØ3x16	x8		x16	UPØ4x20

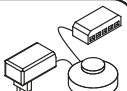

10

LED		G18	
x1	x2	x2	Ø60

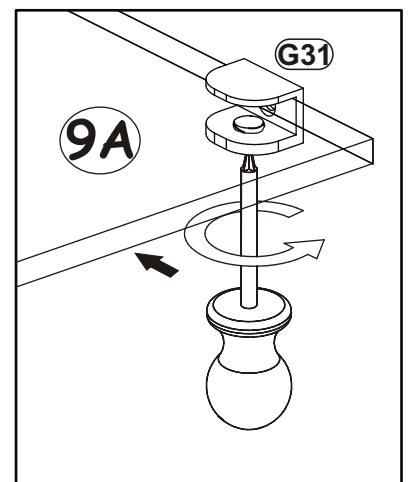
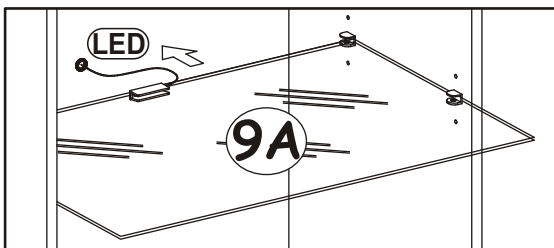
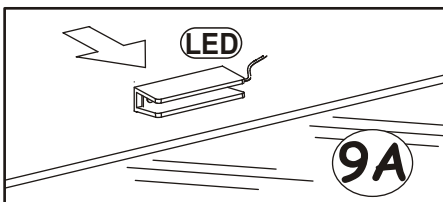
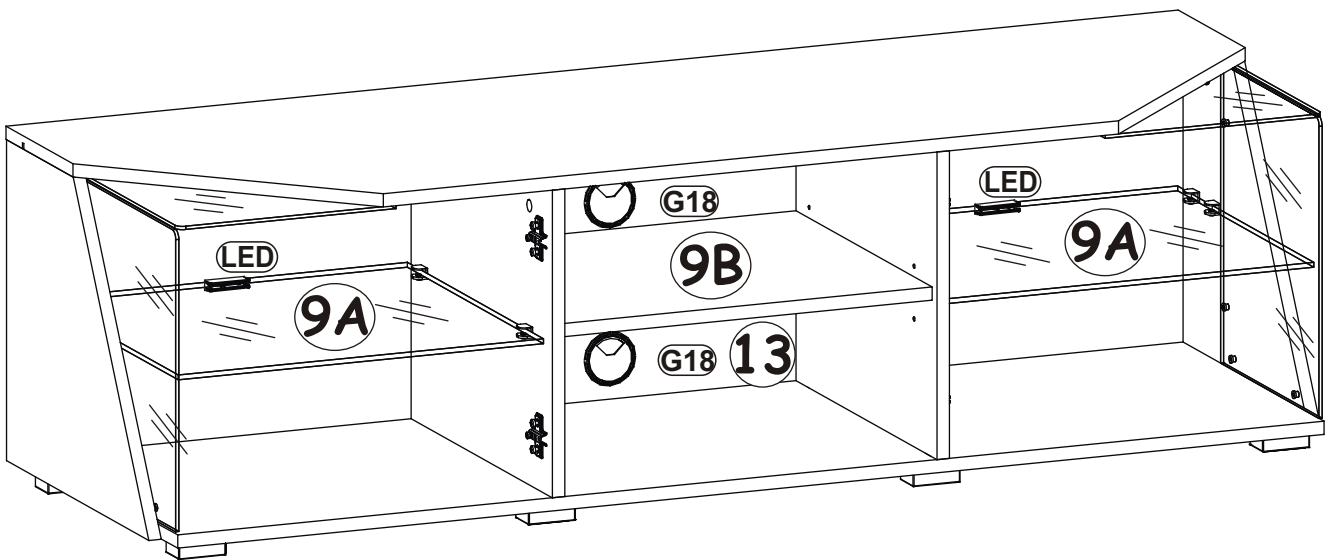
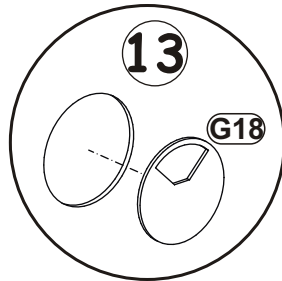

11

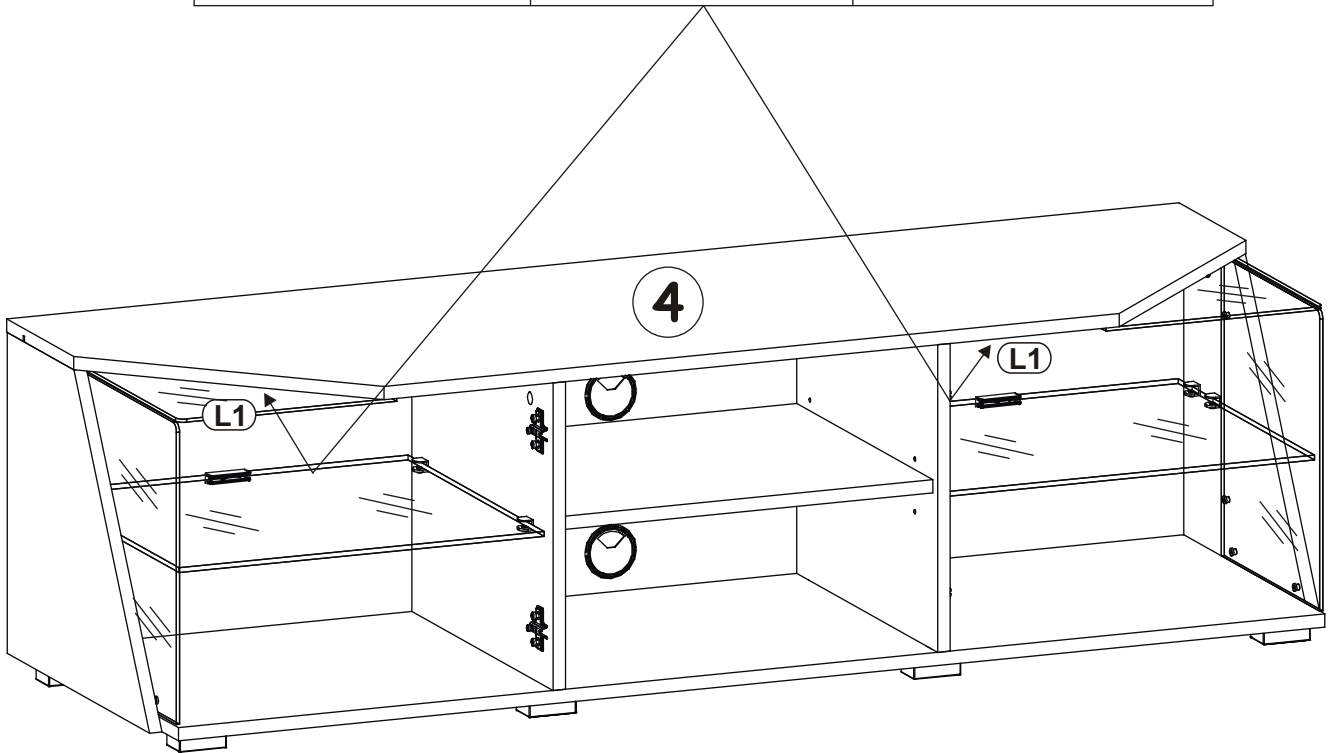
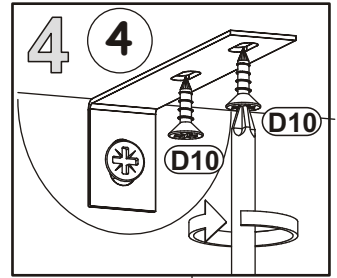
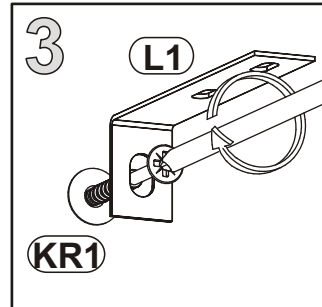
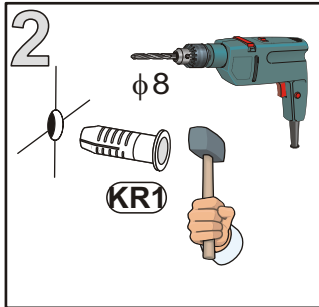
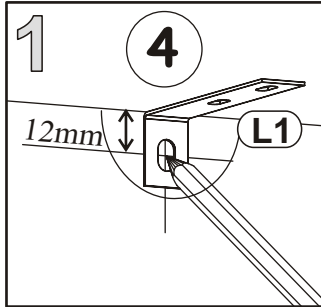
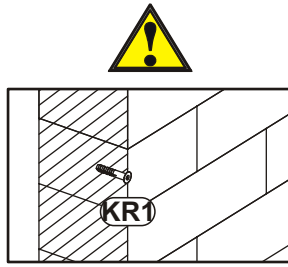
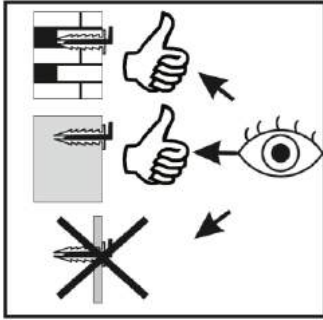
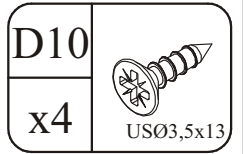
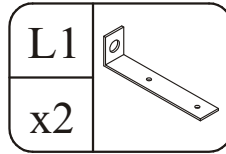
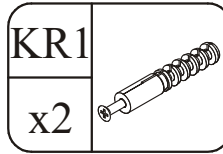

12

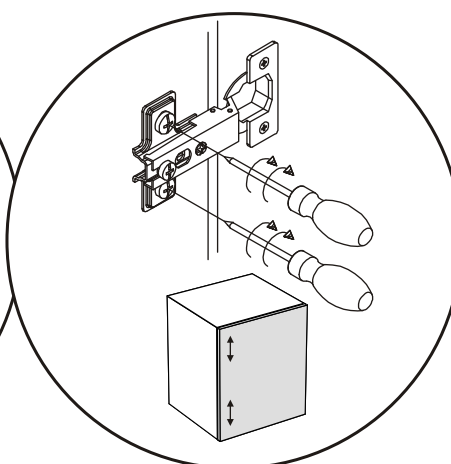
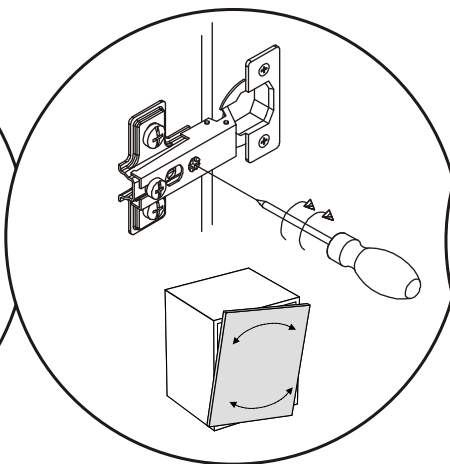
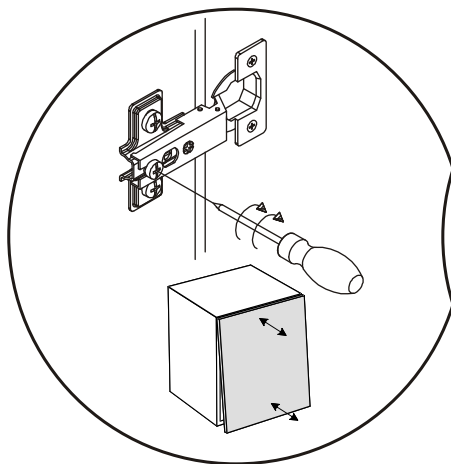
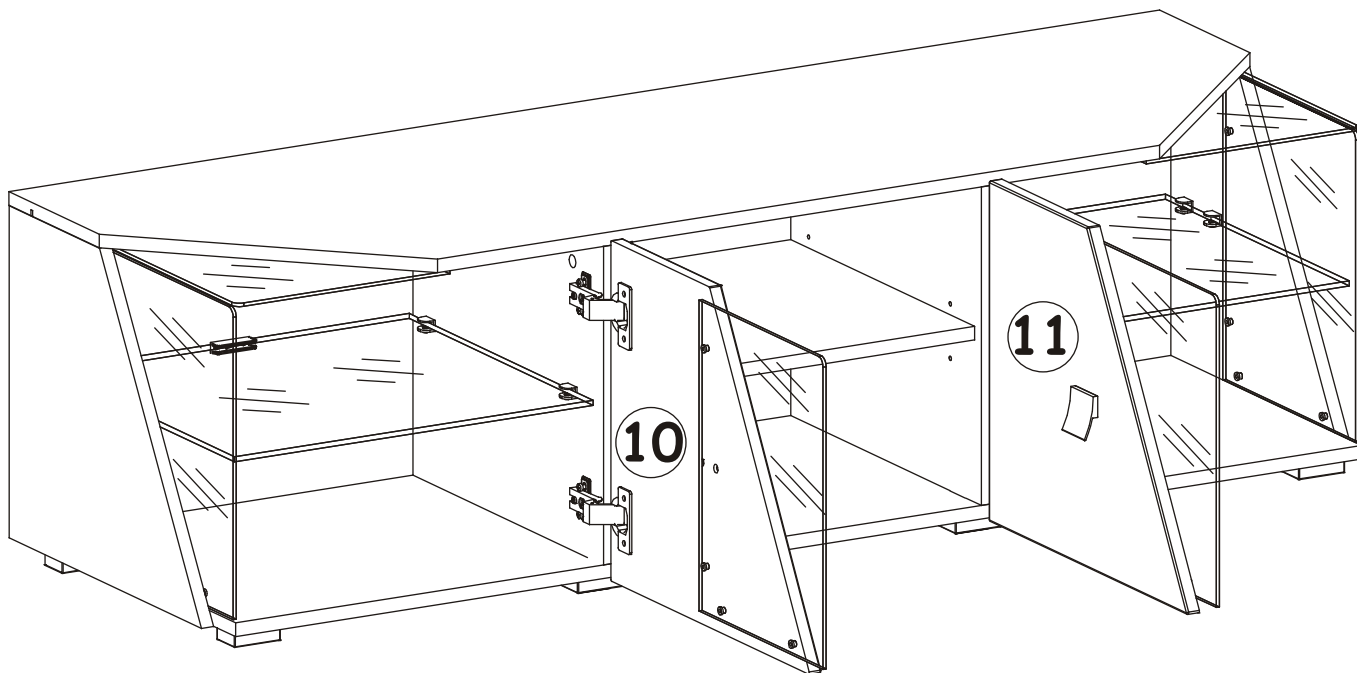

EDGE 29--EE SB

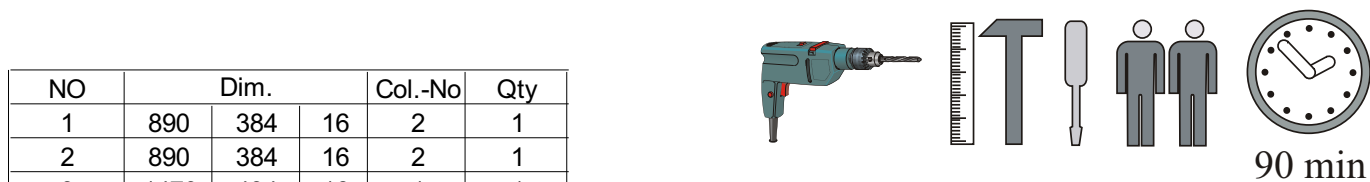
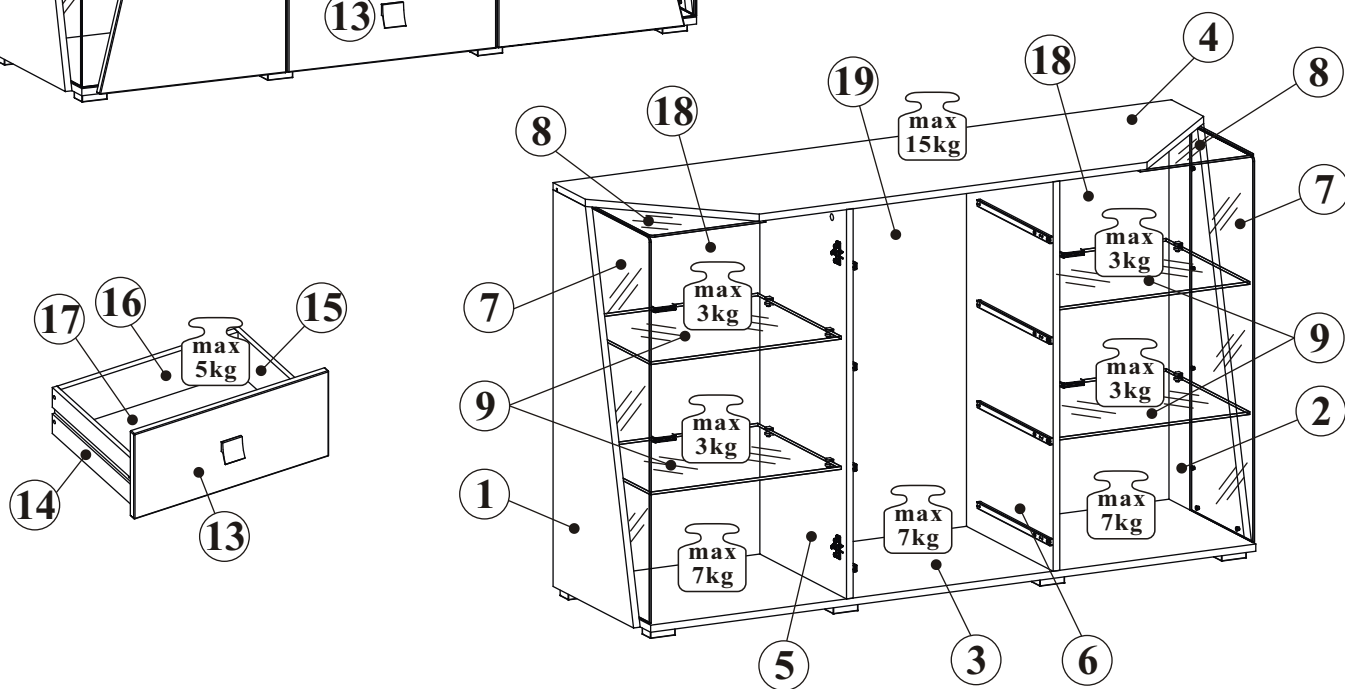
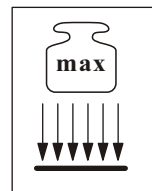
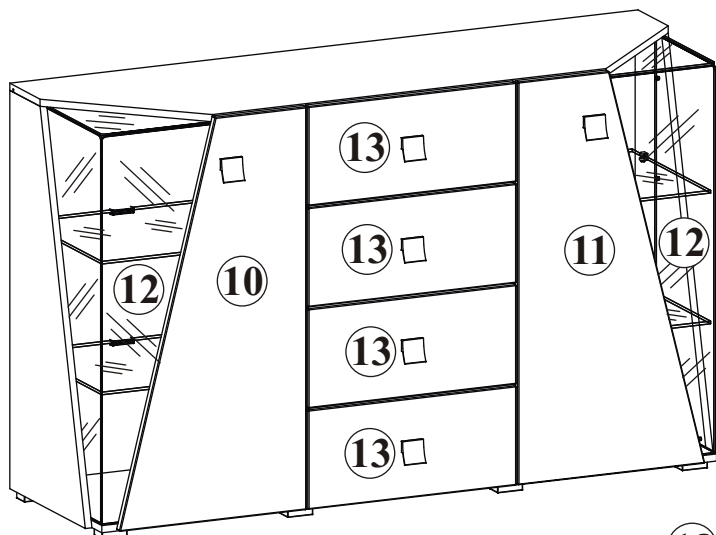

NO	Dim.			Col.-No	Qty
1	890	384	16	2	1
2	890	384	16	2	1
3	1470	434	16	1	1
4	1502	434	16	1	1
5	874	414	16	3	1
6	874	414	16	3	1
7	865	300	4	2	2
8	279	305	4	2	2
9	464	399	6	2	4
10	446	900	16	3	1
11	446	900	16	1	1
12	865	280	4	2	2
13	498	222	16	3	4
14	350	120	12	1	4
15	350	120	12	1	4
16	453	106	16	1	4
17	355	463	3	1	4
18	885	489	3	3	2
19	885	400	3	3	1

EDGE 29--EE SB

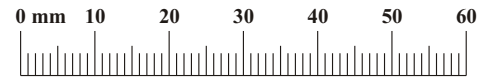

A1 x24 ø8x36	B4 x18	B5 x10 ø15x12	G5 x10	B7 x8 Ø15x10,3	G8 x8 ø20
E23 x4 Ø35 H=8	E2 x4 H=0	D10 x12 USØ3,5x13	S1 x22	B11 x20 Ø7x50	G4 x20
H6 x4 L-342mm	D21 x16 ESØ6x9,5	D18 x8 M4x9	G16 x12	UP13 x60 UPØ3x16	P2 x32
U19 x6	DS4 x4 WSM4x22	D26 x8 M4x22	ST17 x8	UP11 x16 UPØ4x20	LED x1 x4
G31 x12	D20 x12 ESØ6,3x9,5	KR1 x2	L1 x2	G2 x1	

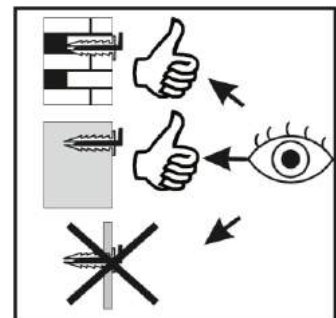
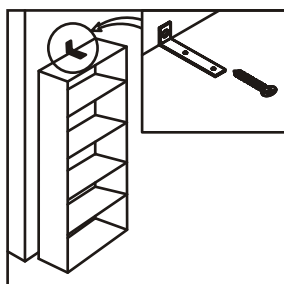
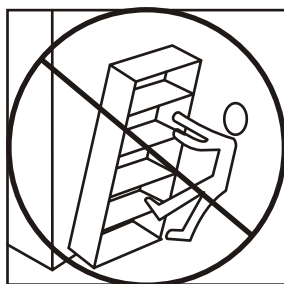
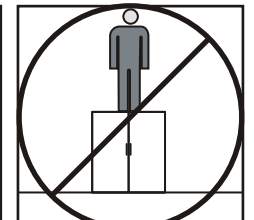
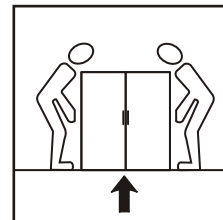
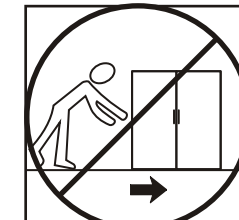
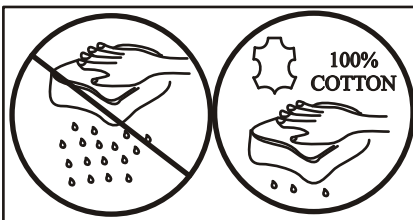
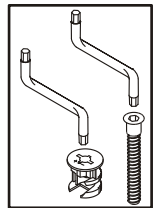
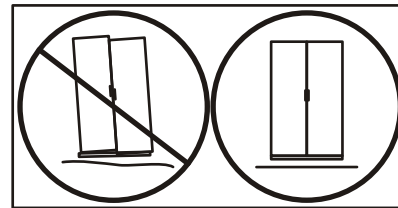
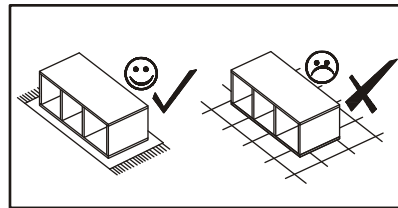
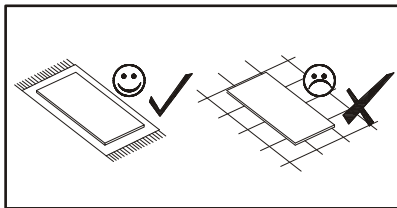
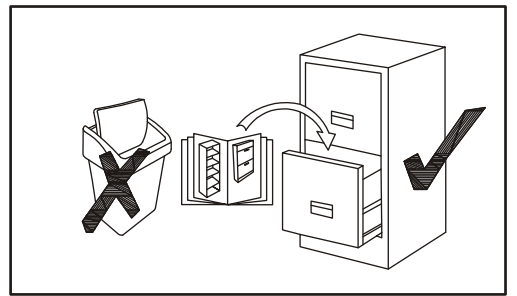
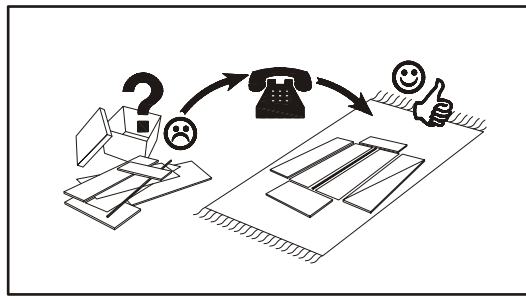
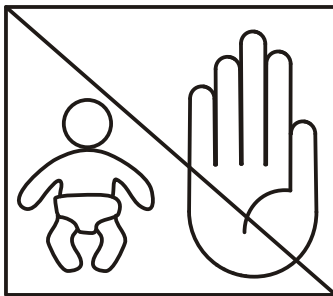



EDGE 29--EE SB

1

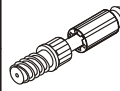
A1	
x4	ø8x36

B4	
x4	



B5	
x2	ø15x12

P2	
x12	

G31	
x4	

D20	
x4	ESØ6,3x9,5

UP13	
x12	UPØ3x16

10,3mm		B7
12mm		B5

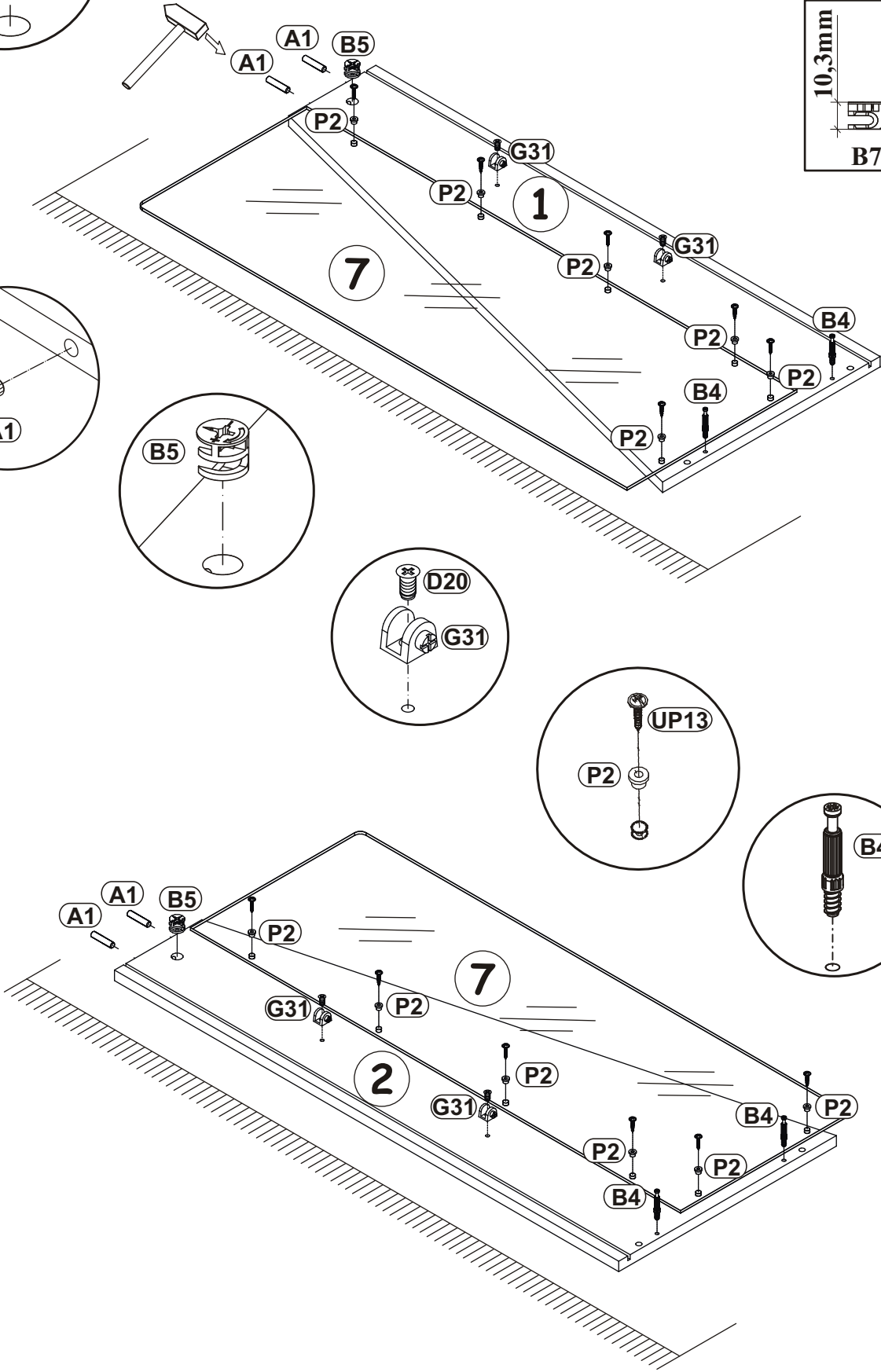
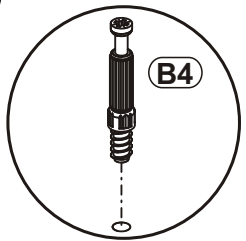
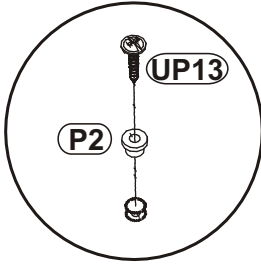
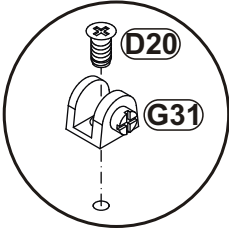
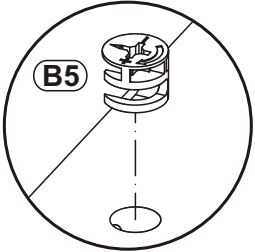
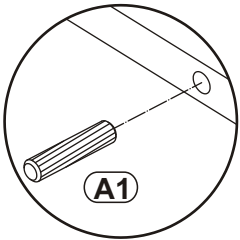
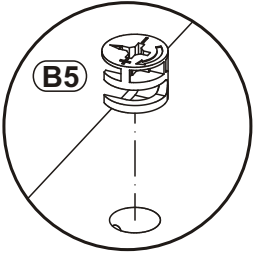

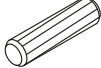

EDGE 29--EE SB

2

A1	
x4	ø8x36

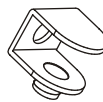
B5	
x2	ø15x12

G31	
x4	

D20	
x4	ESØ6,3x9,5

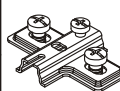
E2	
x2	H=0

H6	
x2	L-342mm

D21	
x8	ESØ6x9,5

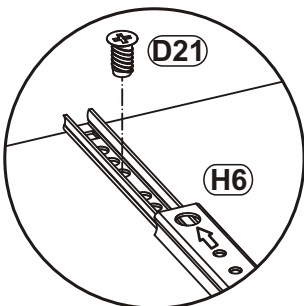
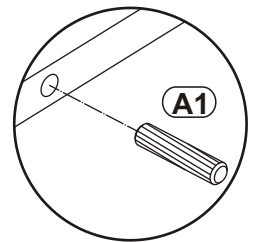
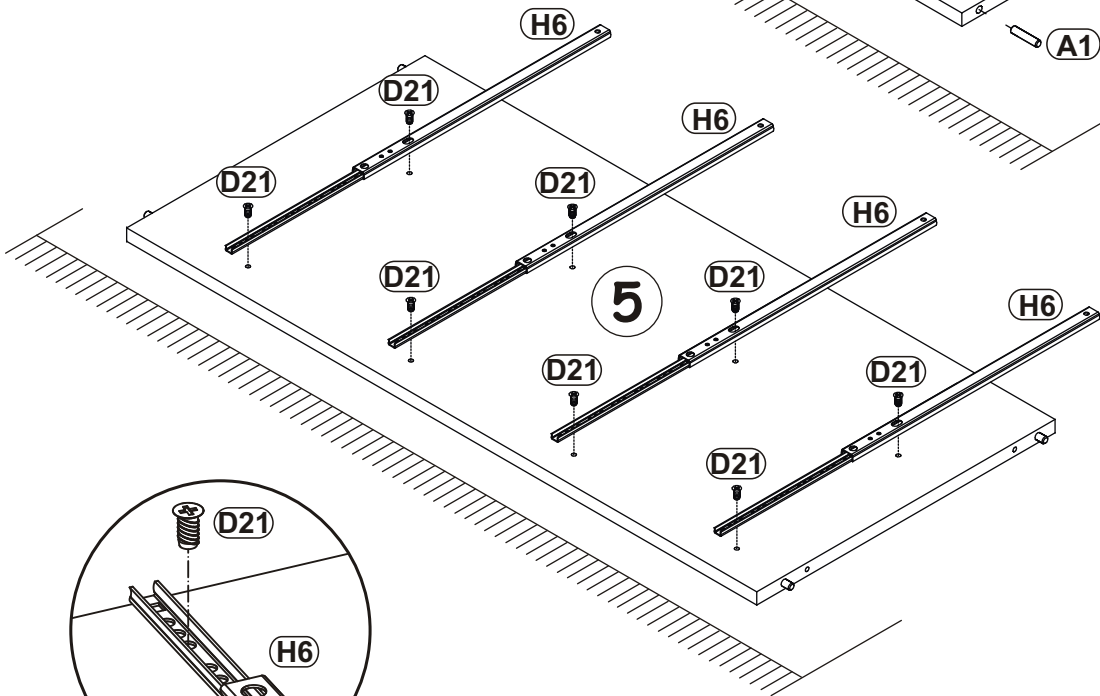
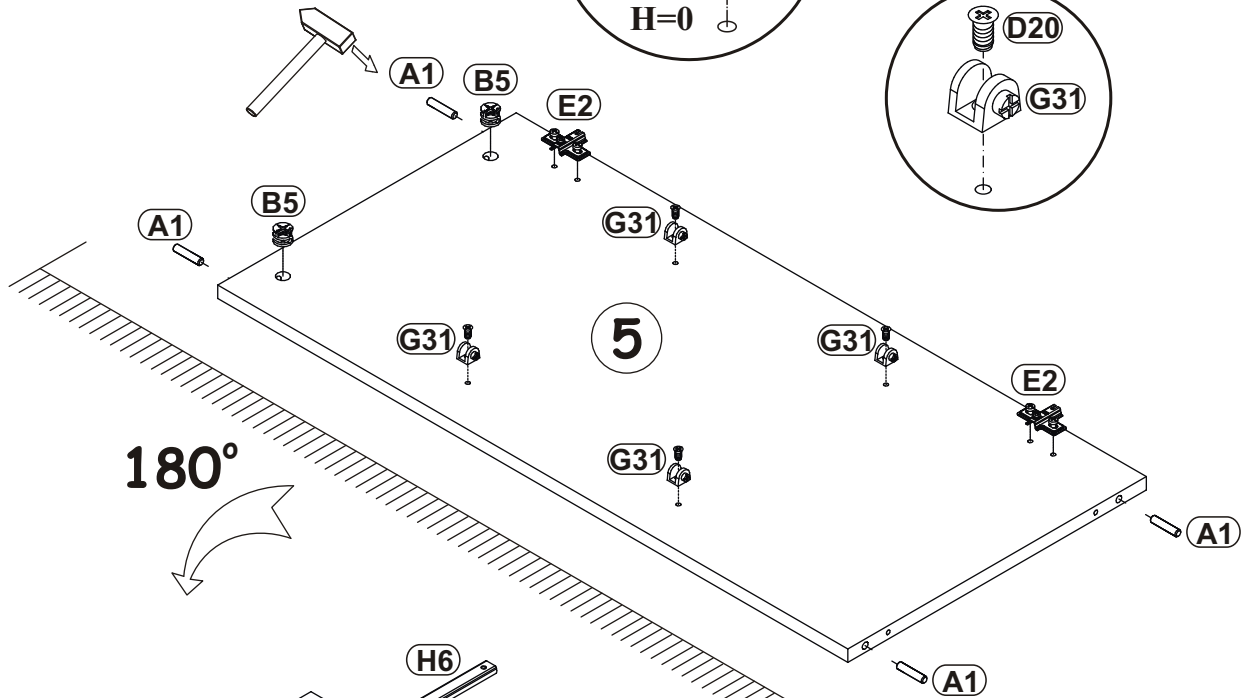
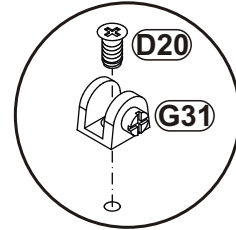
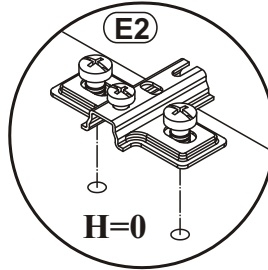
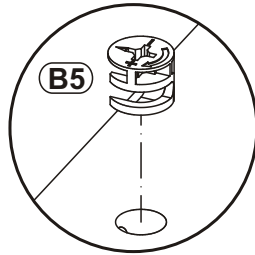
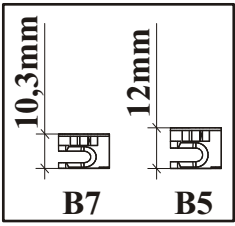

EDGE 29--EE SB

3

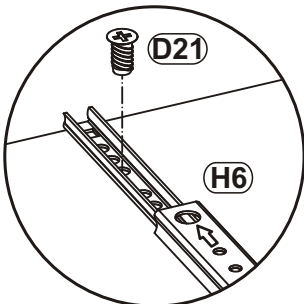
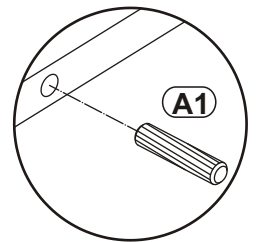
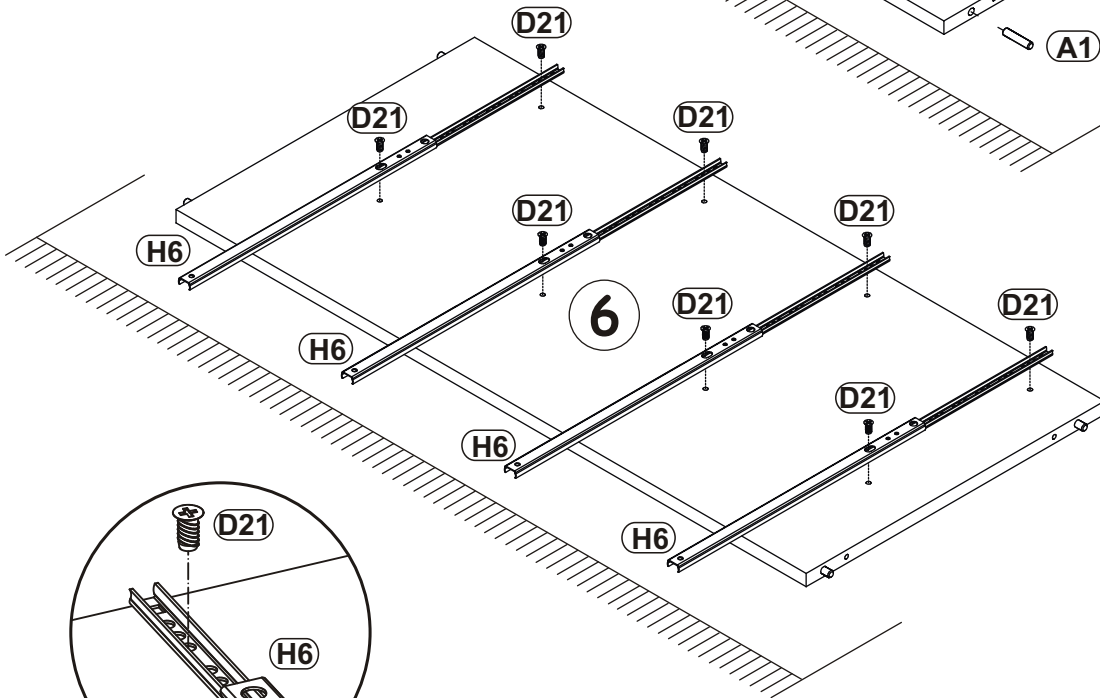
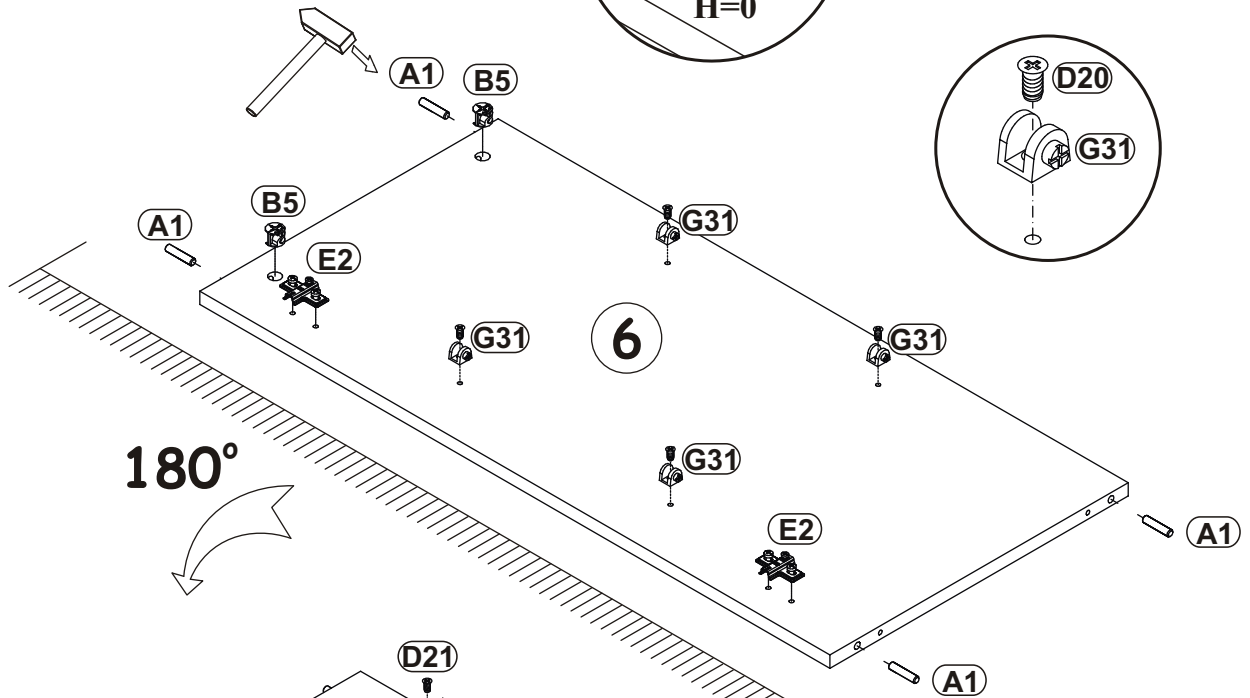
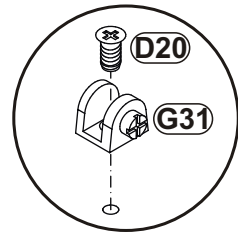
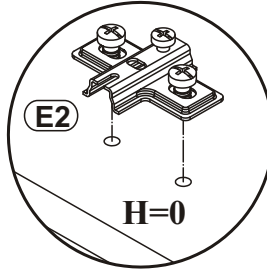
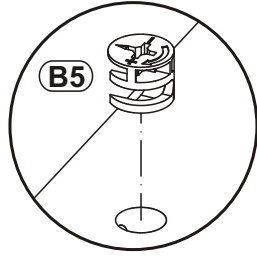
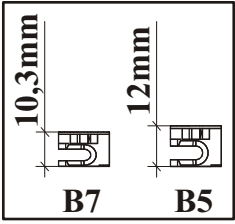
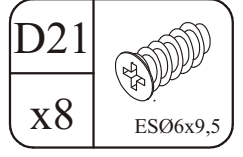
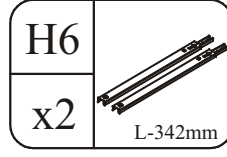
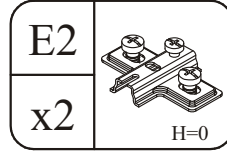
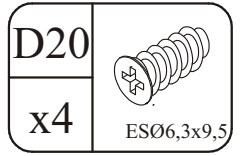
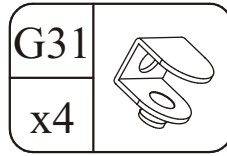
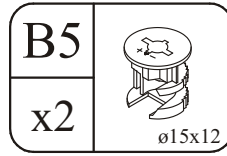
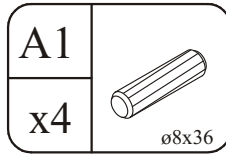

EDGE 29--EE SB

4

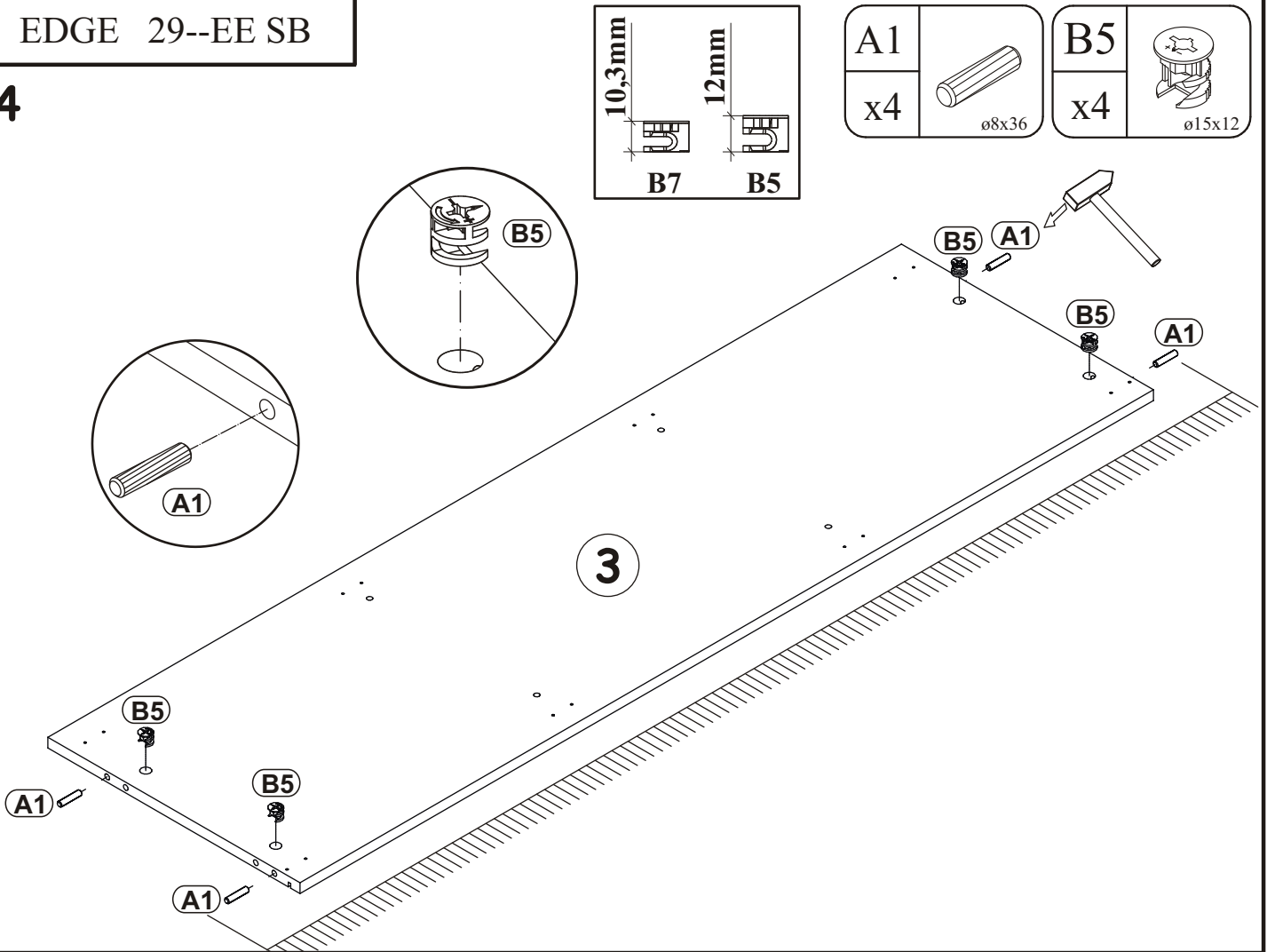

5

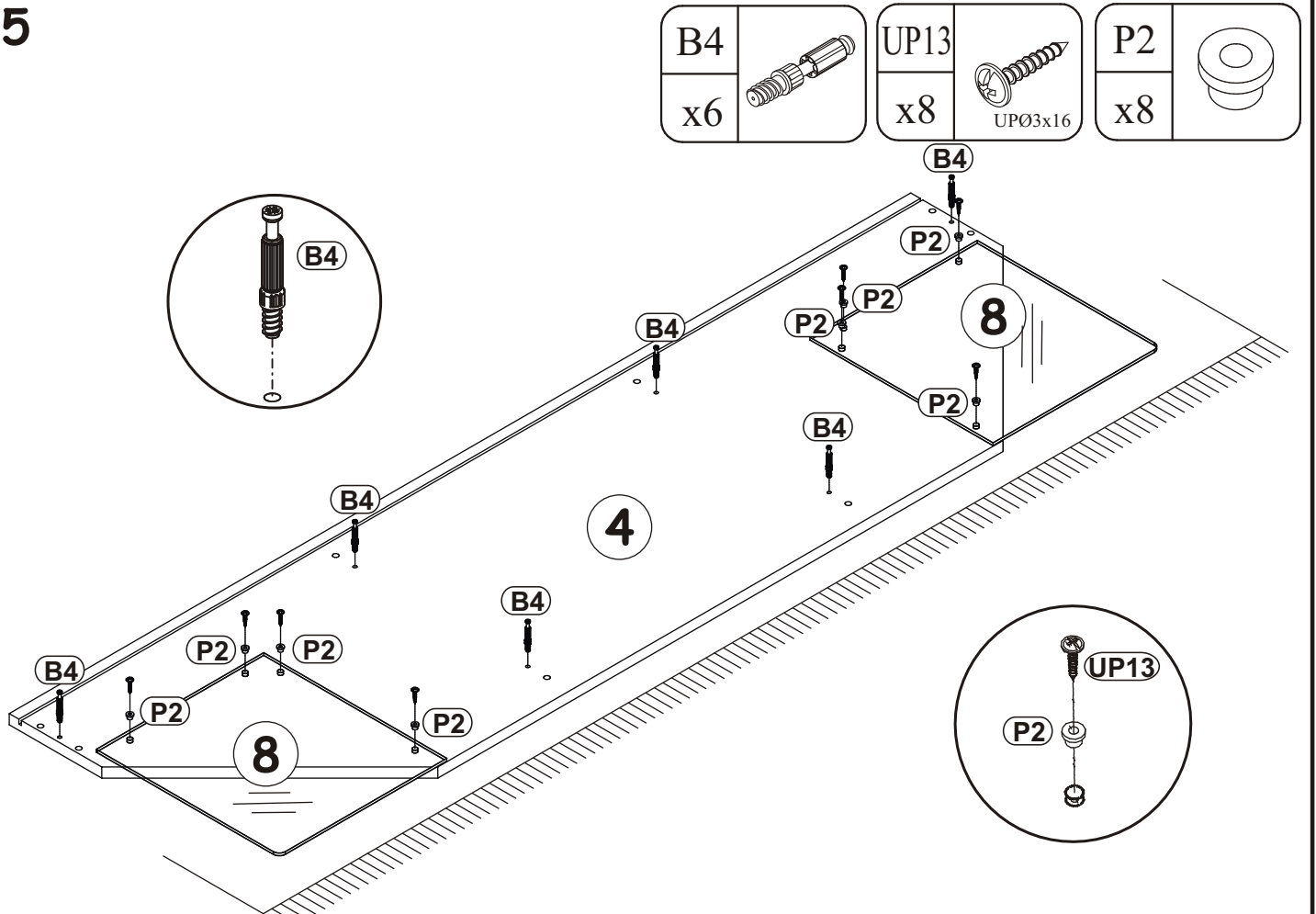

6

U19		DS4	
x2		x4	WSM4x22

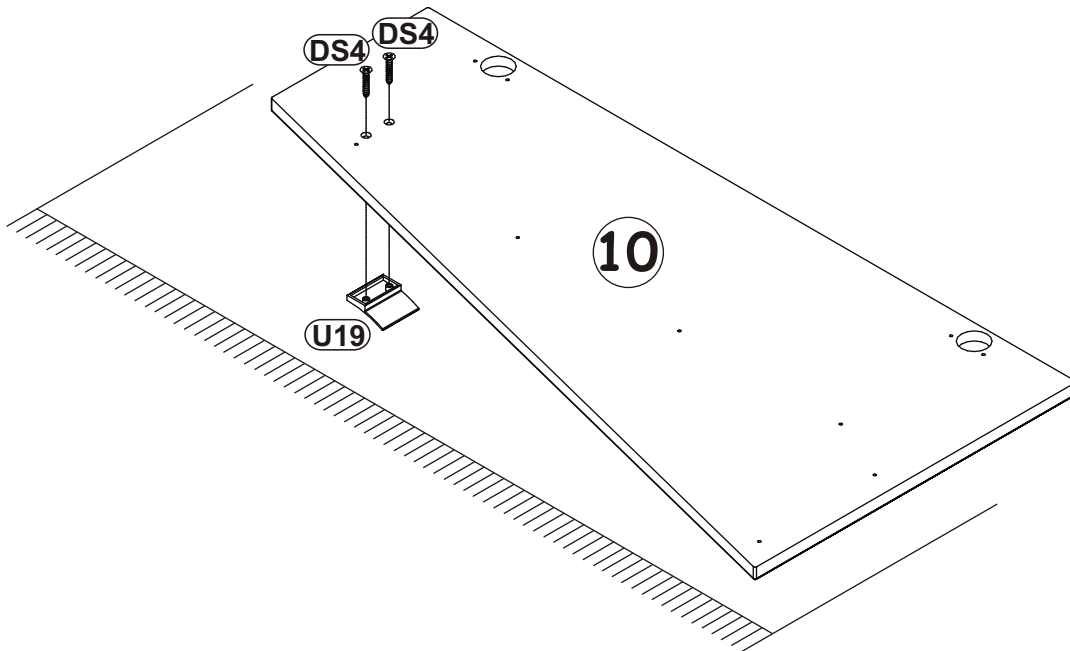
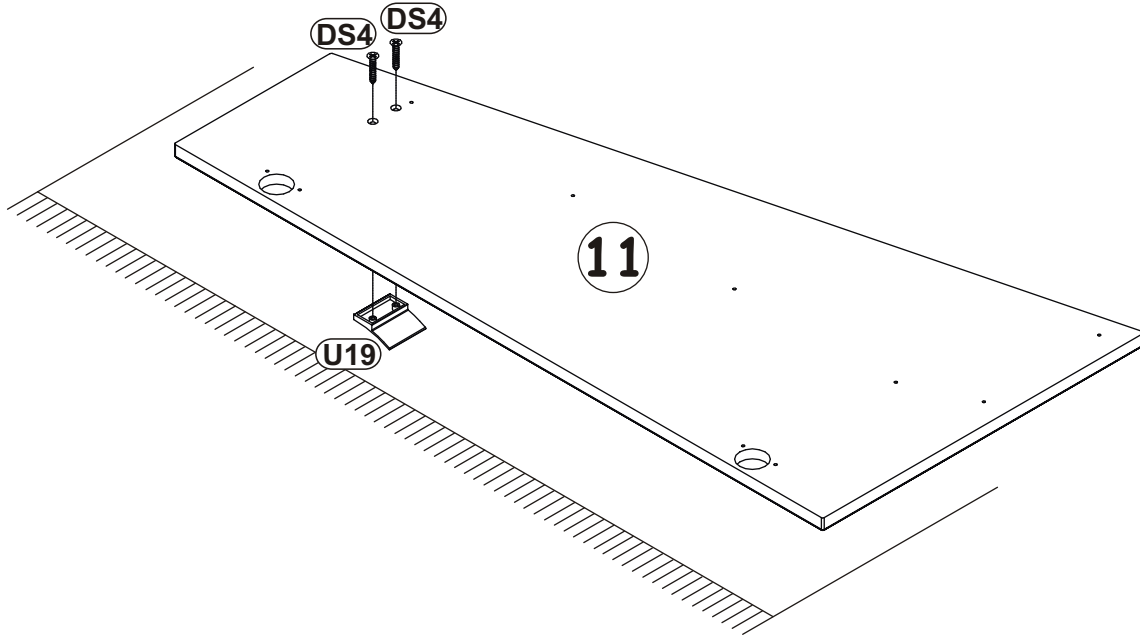

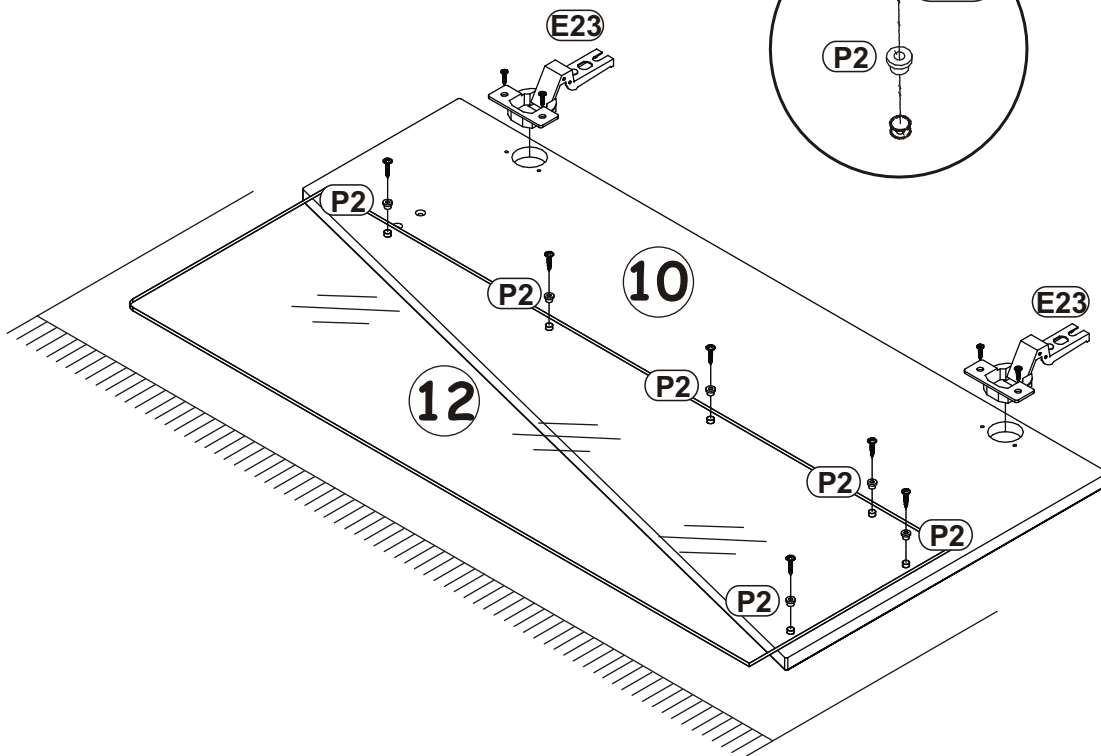
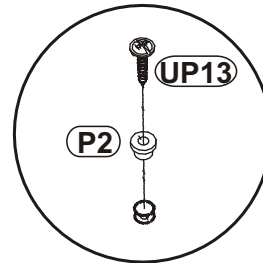
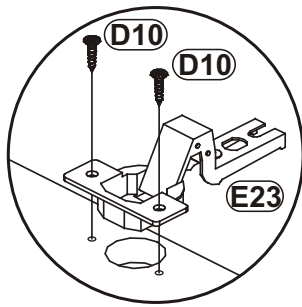
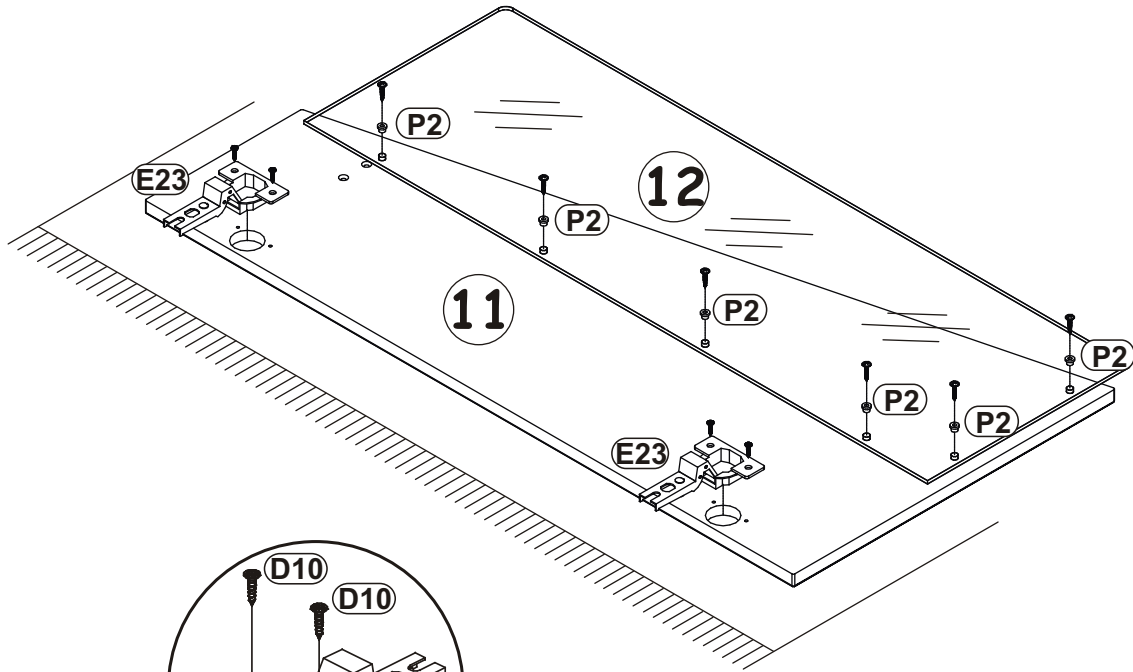
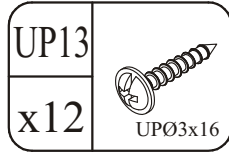
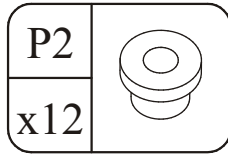
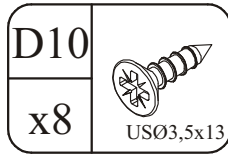
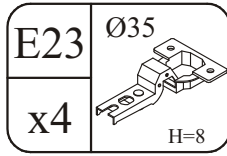

8

B4

x8

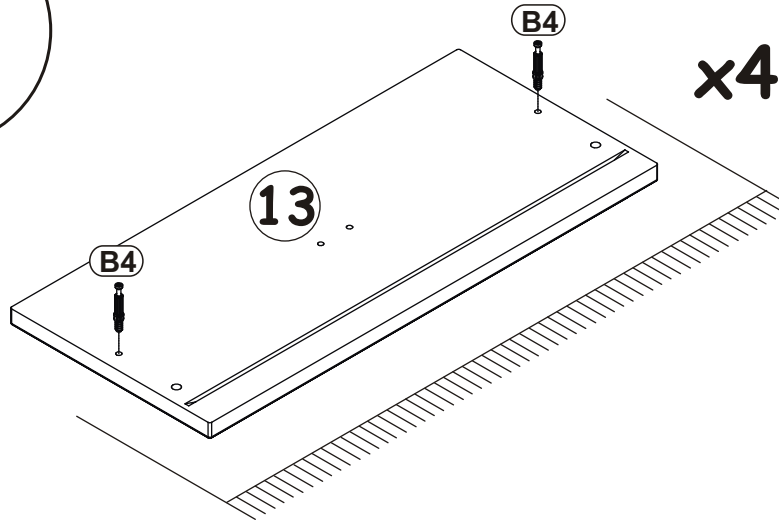
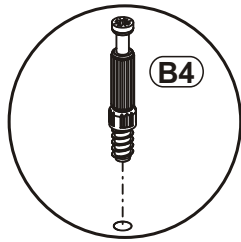
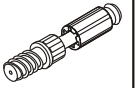

9

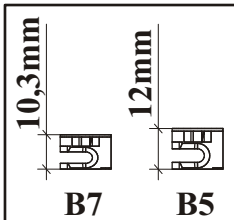

A1

x8

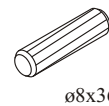

ø8x36

B7



x8

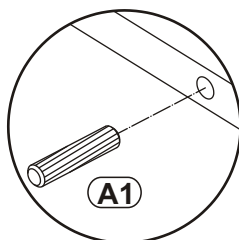
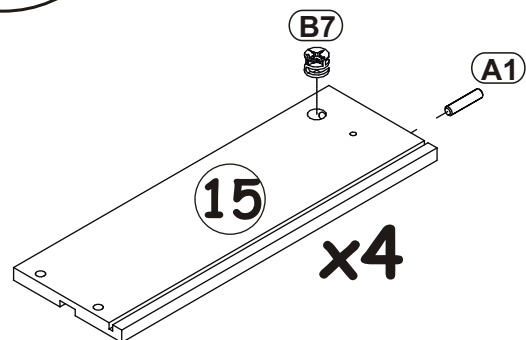
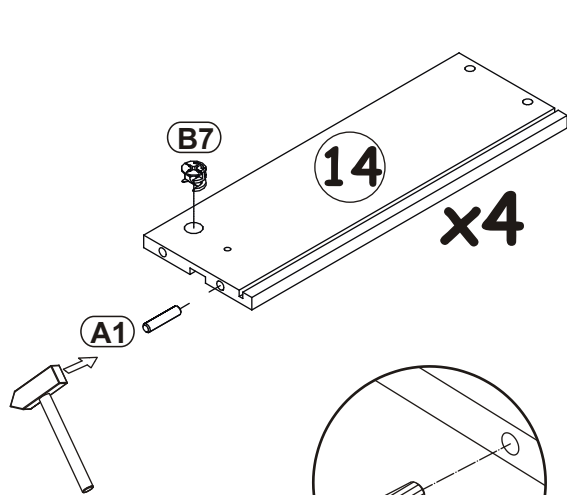
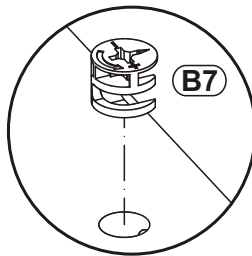

Ø15x10,3

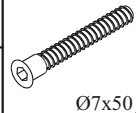

10

B11		G4	
x16	Ø7x50	x16	

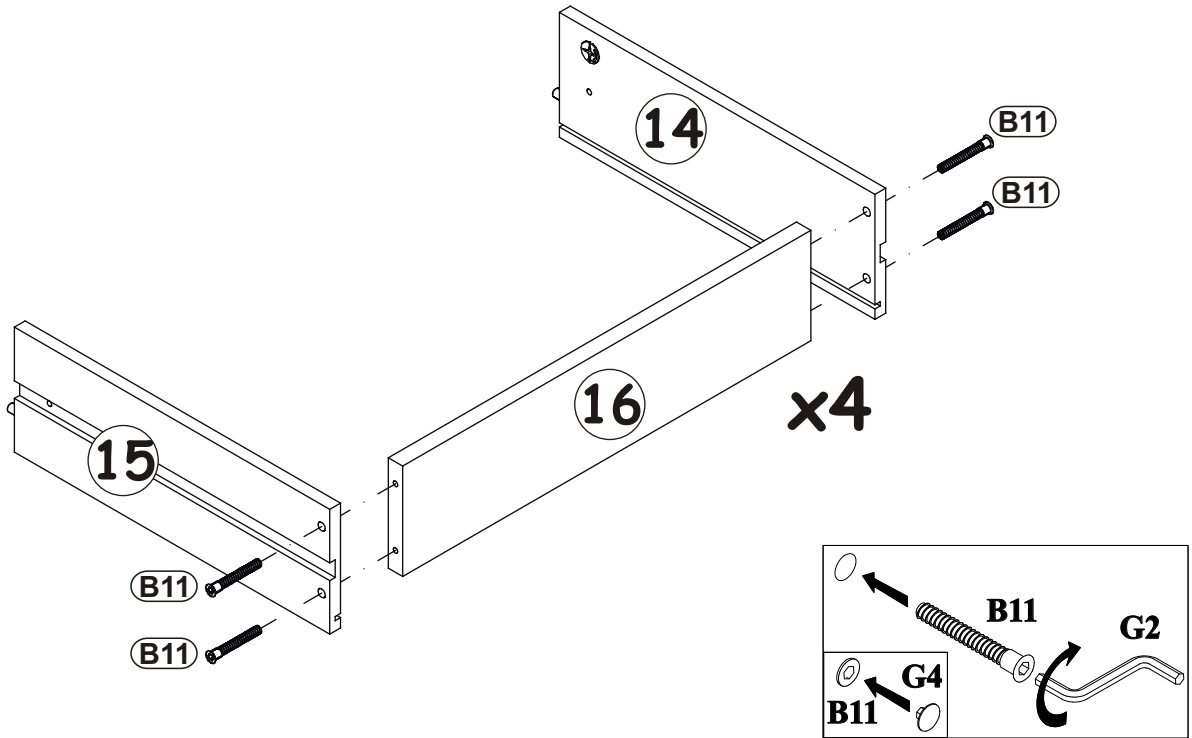

11

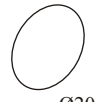
G8	
x8	Ø20

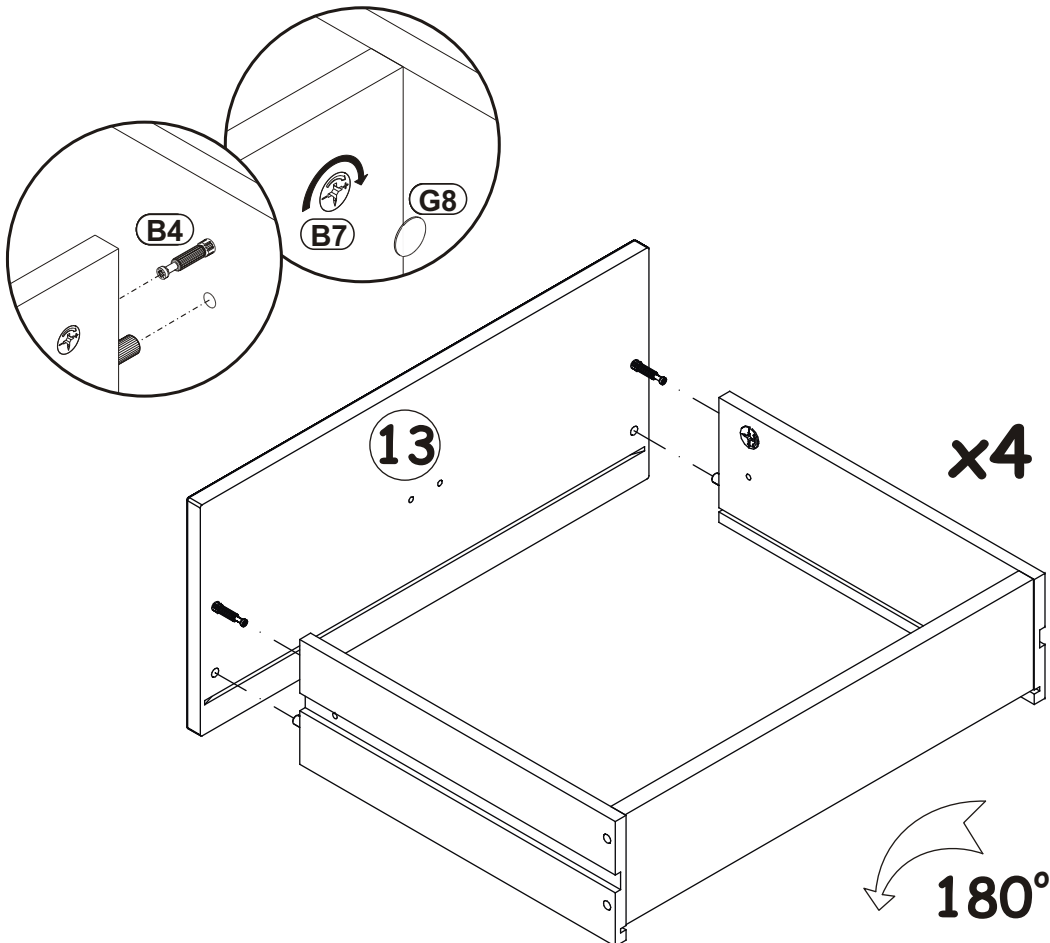

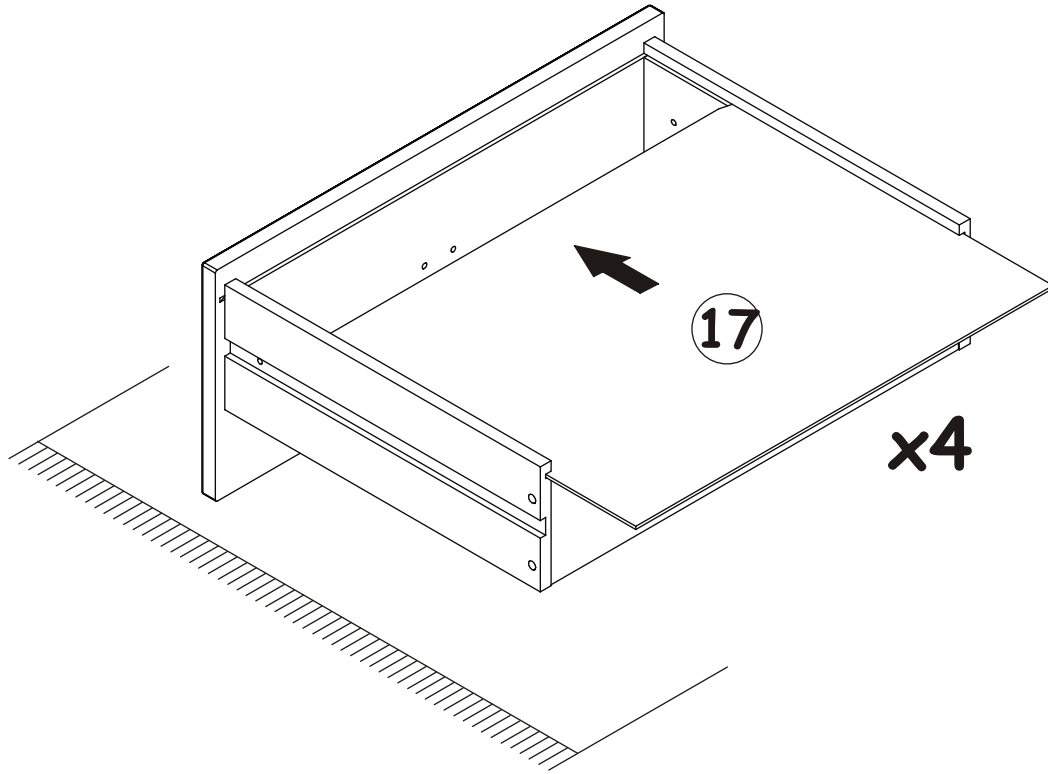

12

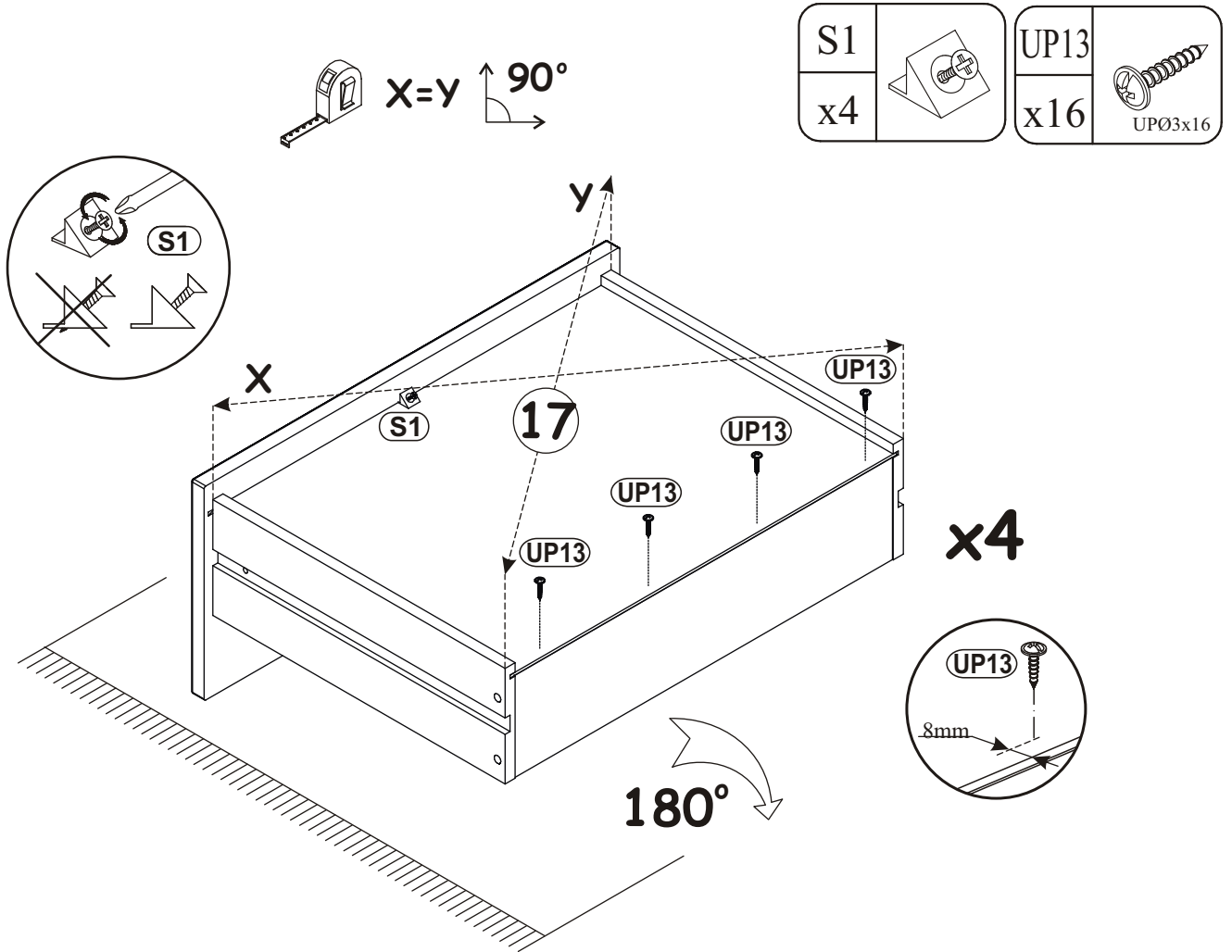

13



U19		D26	
x4		x8	M4x22

14

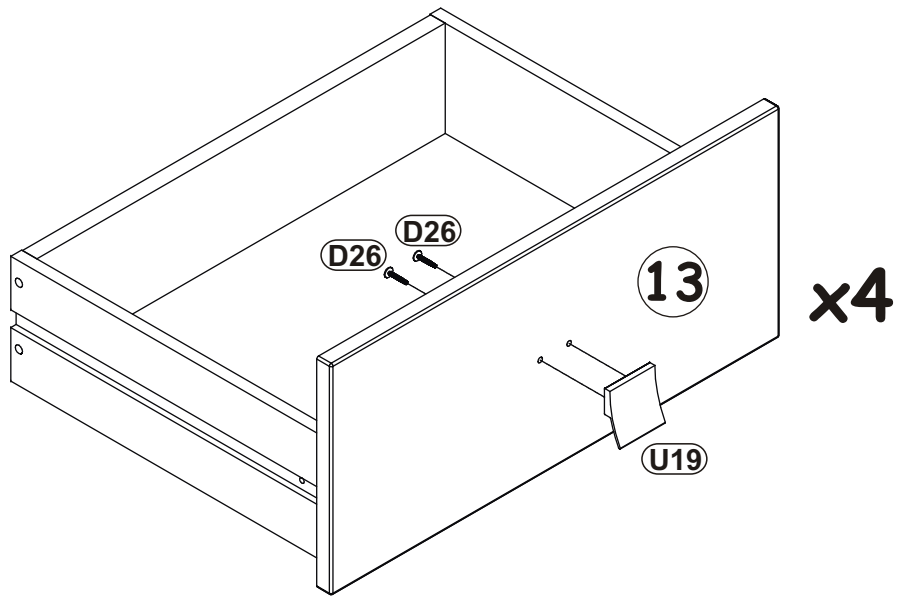

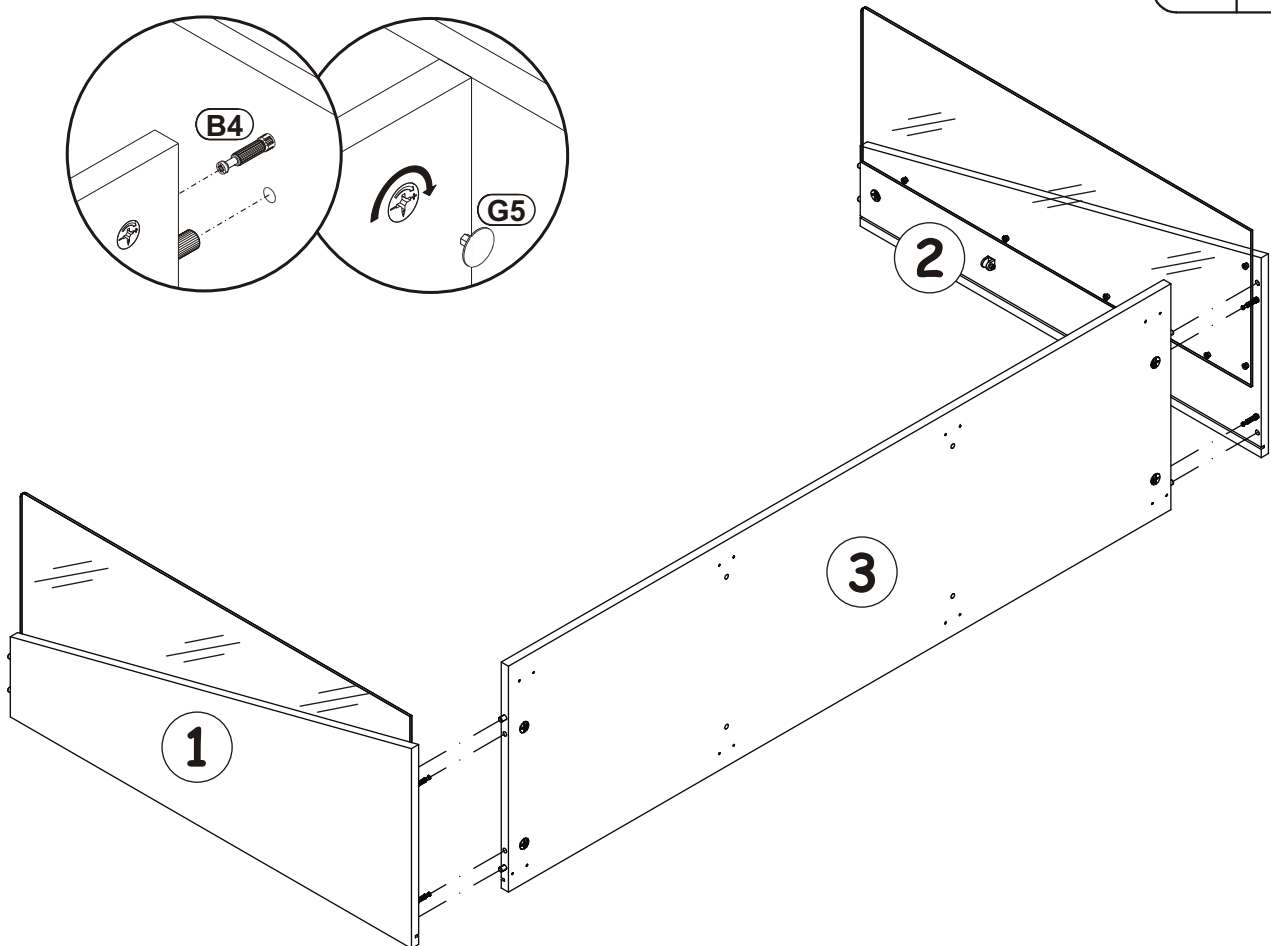

15

G5	
x4	



16

B11		G4	
x4	Ø7x50	x4	

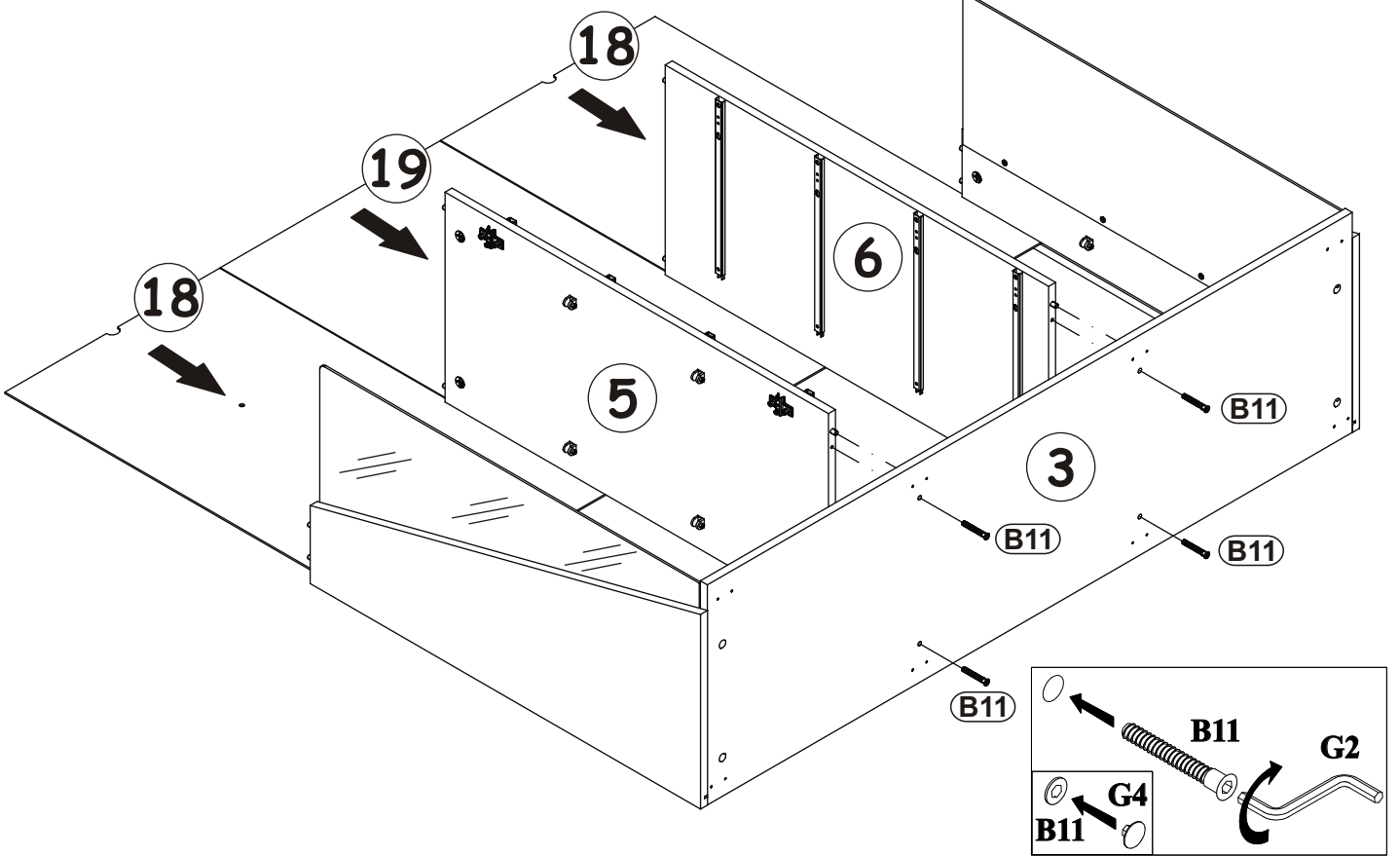

17

G5	
x6	

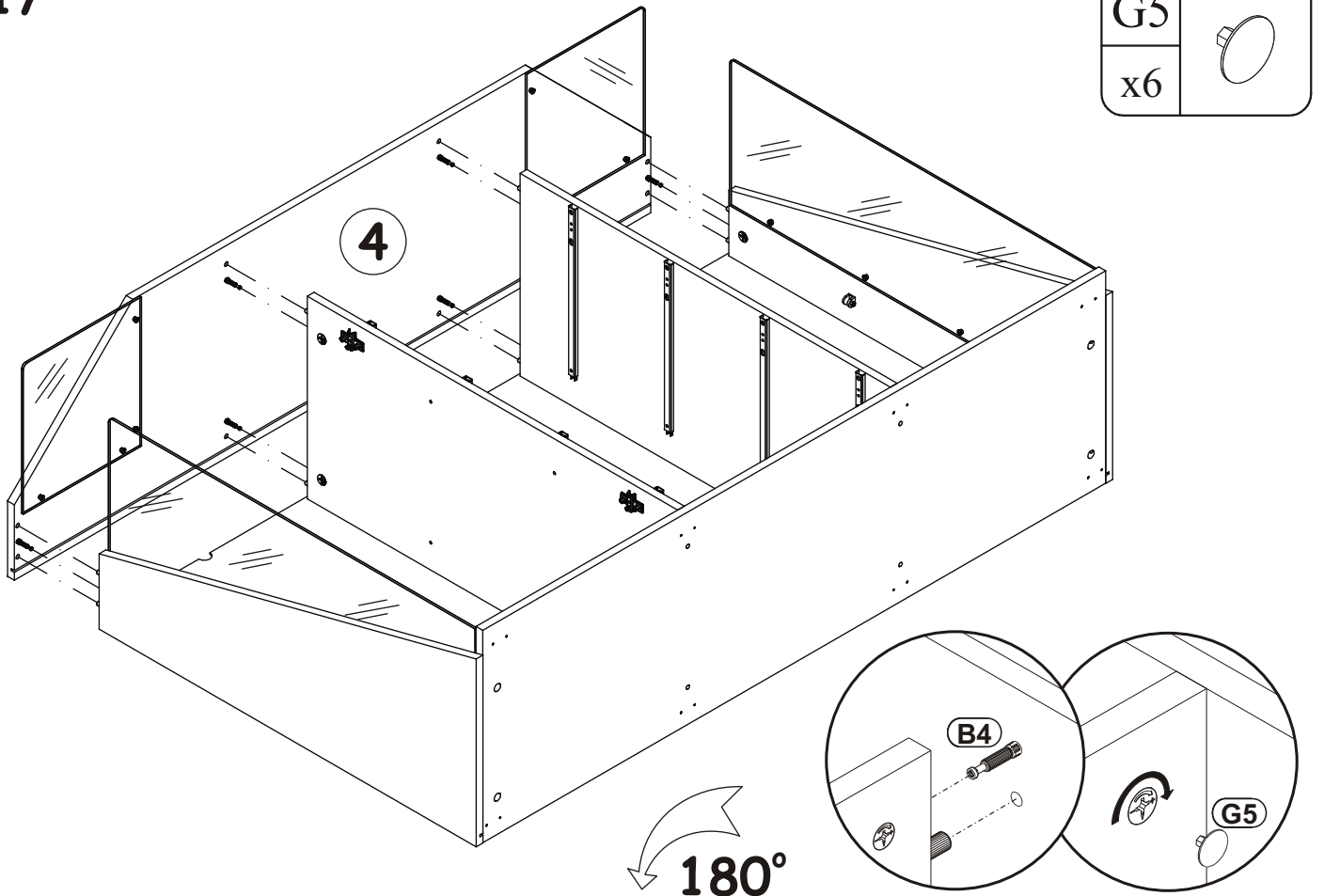

18

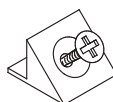
S1	
x18	

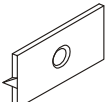
G16	
x12	

UP13	
x12	UPØ3x16

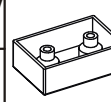

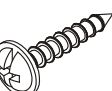
ST17	
x8	

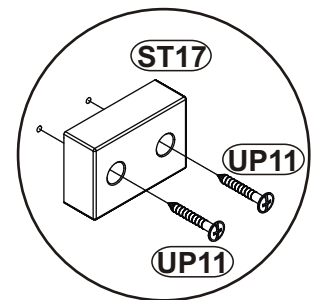
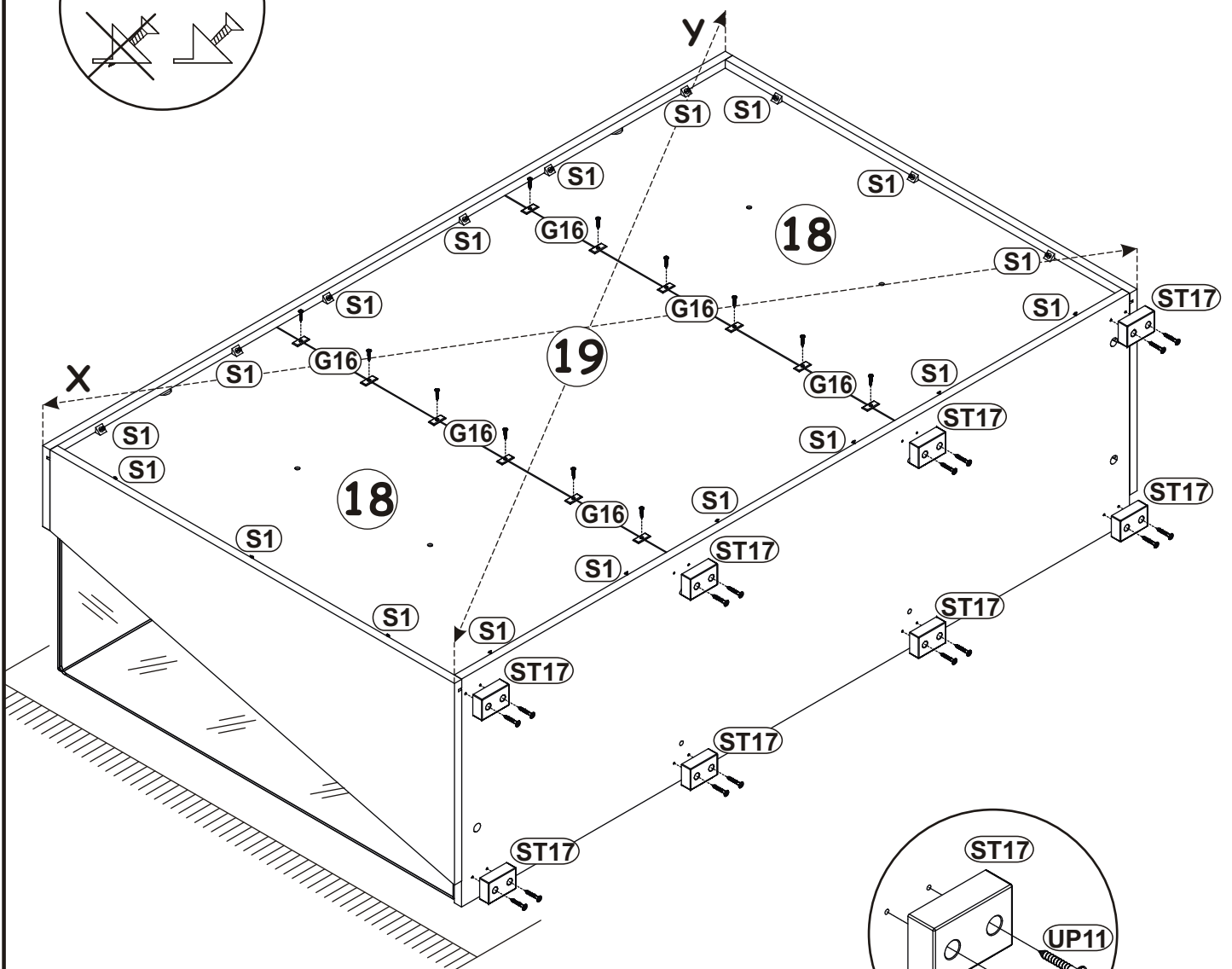
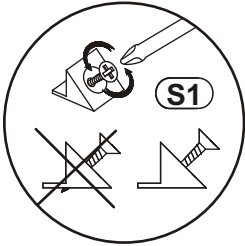
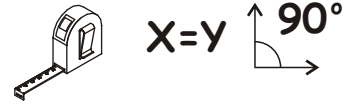
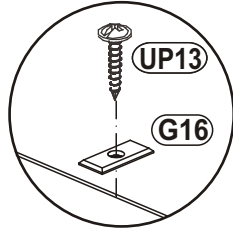
UP11	
x16	UPØ4x20

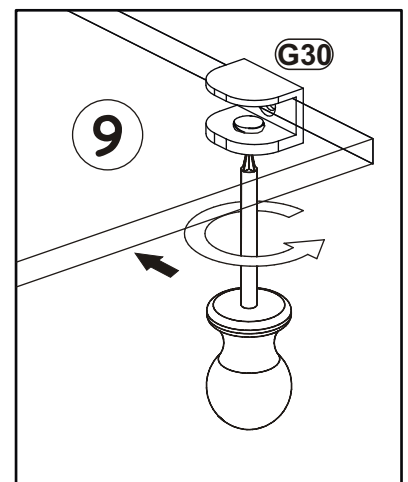
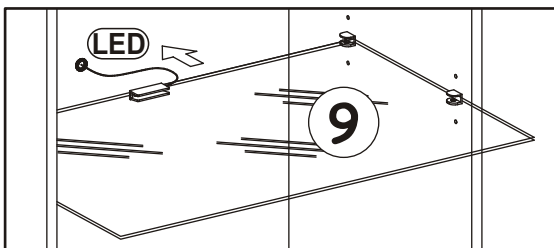
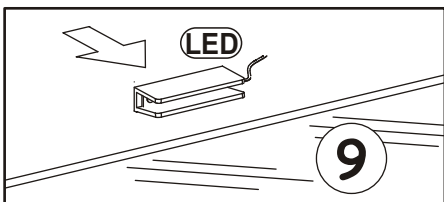
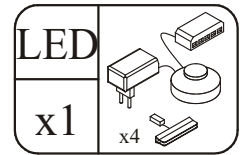

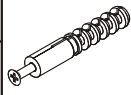
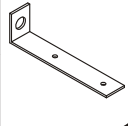

20

KR1		L1		D10	
x2		x2		x4	USØ3,5x13

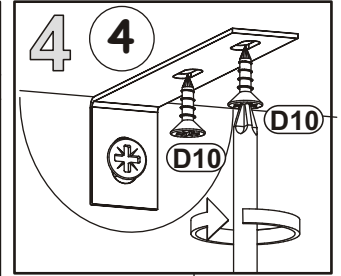
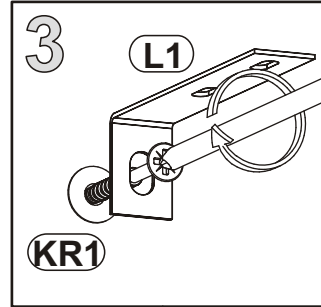
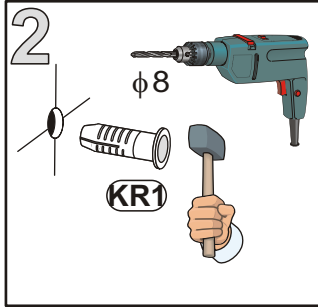
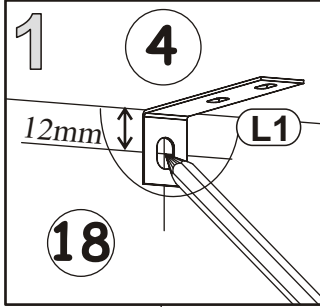
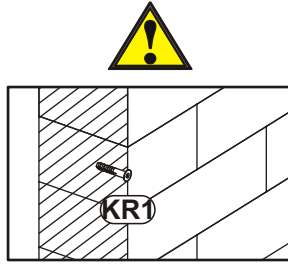
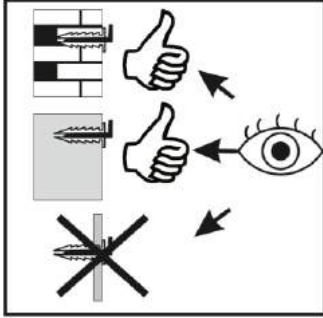

21

D18	
x8	M4x9

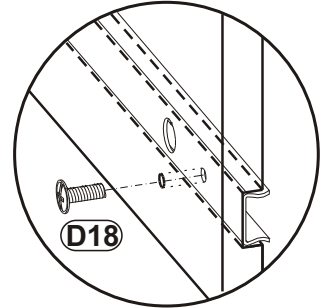
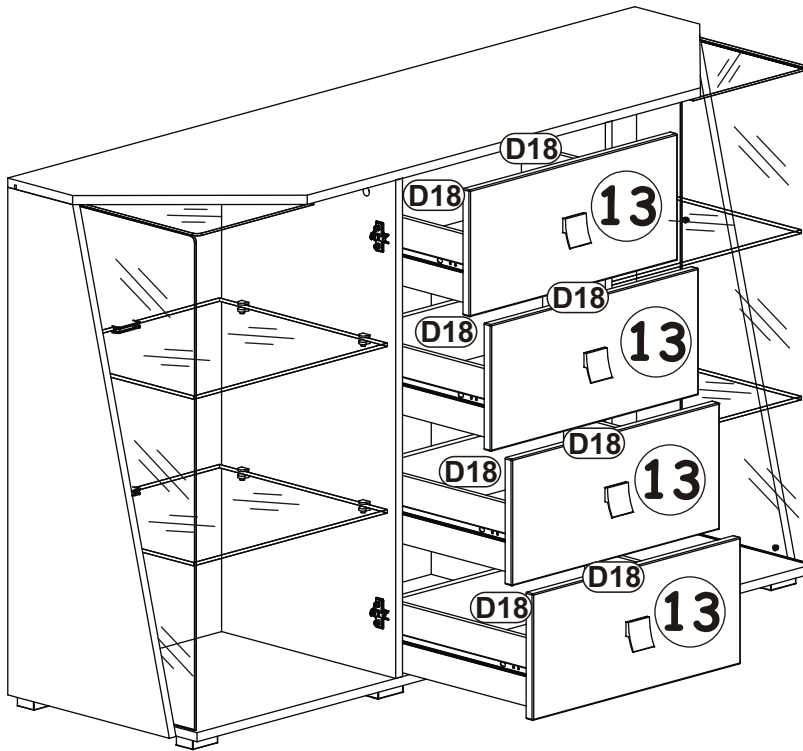

22

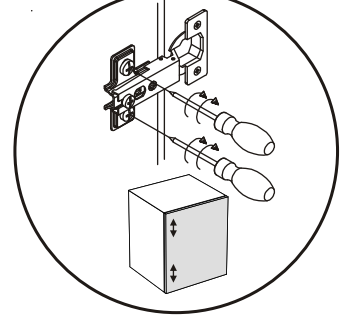
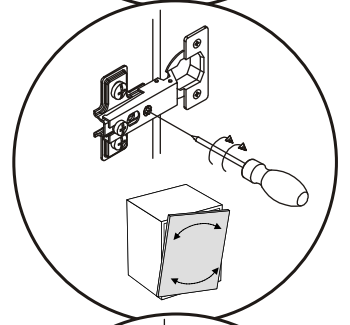
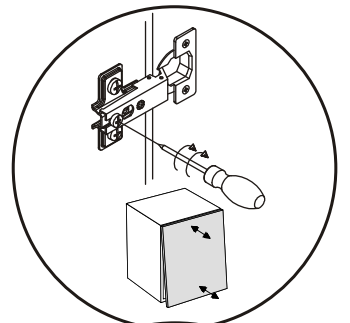
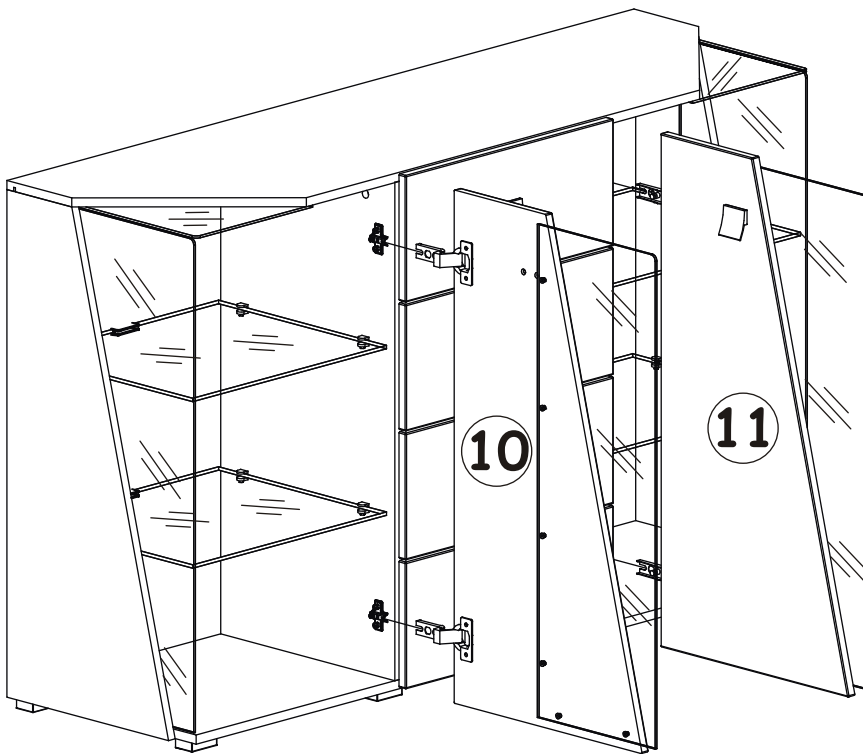

EDGE 29 -- EE WSN

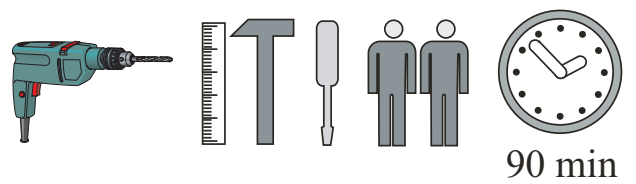
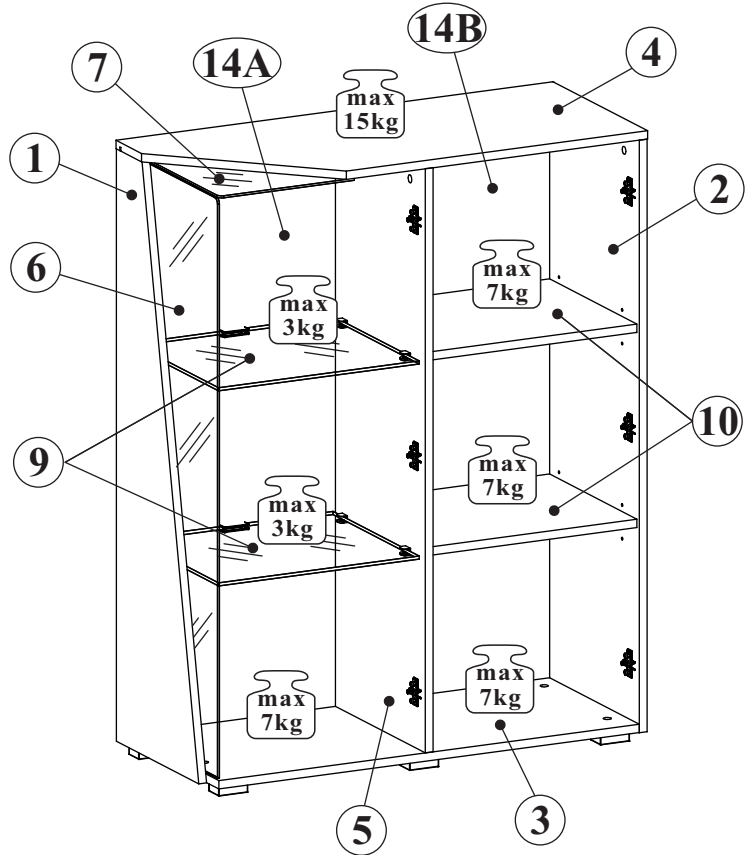
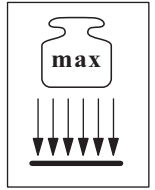
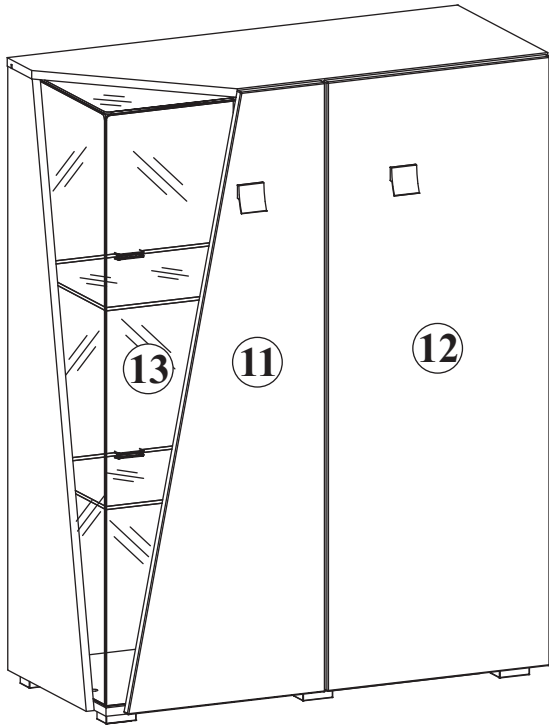

NO	Dim.			Col.-No	Qty
1	1130	334	16	1	1
2	1130	384	16	1	1
3	868	384	16	2	1
4	902	384	16	2	1
5	1114	364	16	1	1
6	1105	300	4	1	1
7	305	279	4	2	1
9	414	349	6	2	2
10	426	354	16	2	2
11	396	1140	16	1	1
12	446	1140	16	1	1
13	1105	280	4	1	1
14A	1125	440	3	1	1
14B	1125	440	3	2	1

EDGE 29 -- EE WSN

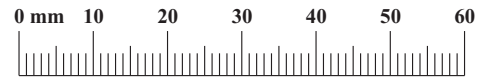

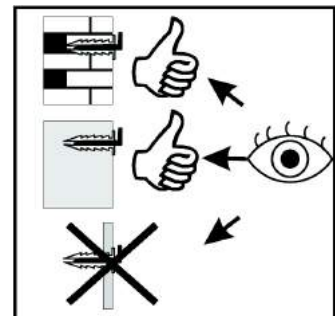
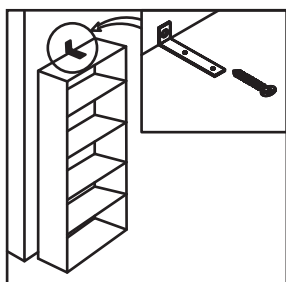
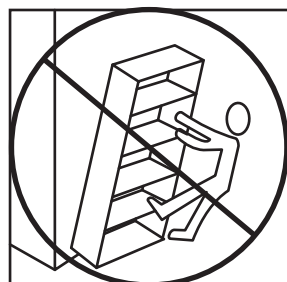
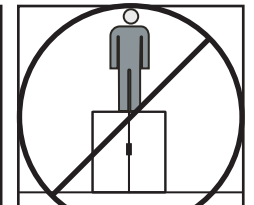
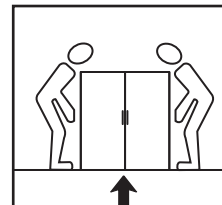
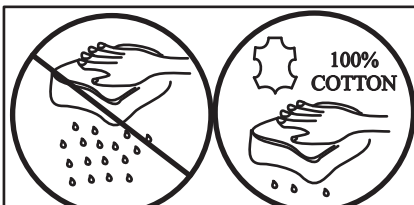
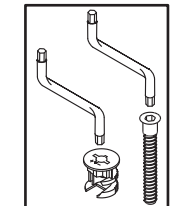
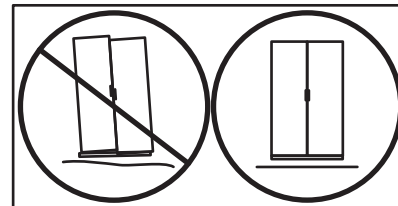
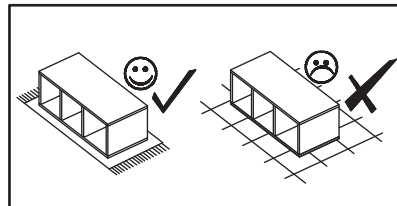
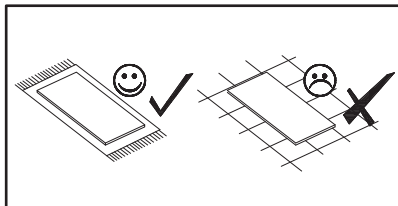
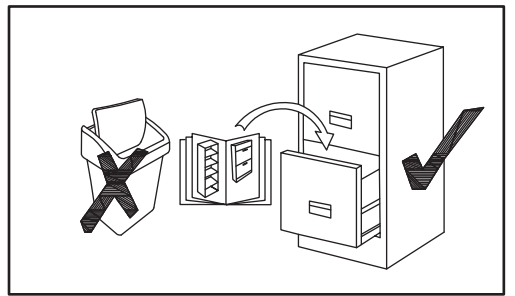
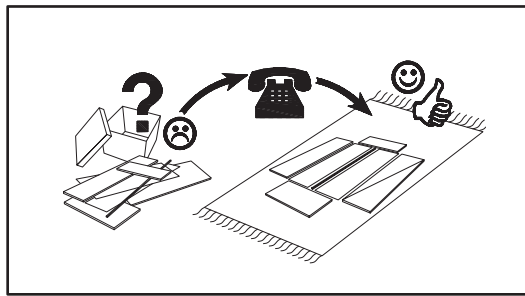
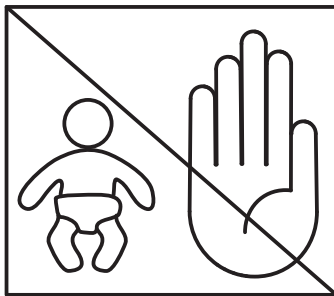

A1 x11 ø8x36	B4 x9	B5 x9 ø15x12	G5 x9	B11 x2 ø7x50	G4 x2
E21 x3 Ø35 H=0	E2 x6 H=0	E23 x3 Ø35 H=8	D10 x16 USØ3,5x13	G7 x8	G31 x6
ST17 x6	UP11 x12 UPØ4x20	G16 x7	UP13 x25 UPØ3x16	P2 x18	D20 x6 ESØ6,3x9,5
LED x1 x2	S1 x16	KR1 x2	L1 x2	G2 x1	U19 x2
DS4 x4 WSM4x22					



EDGE 29 -- EE WSN

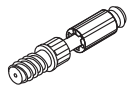

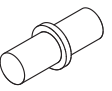
1

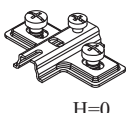

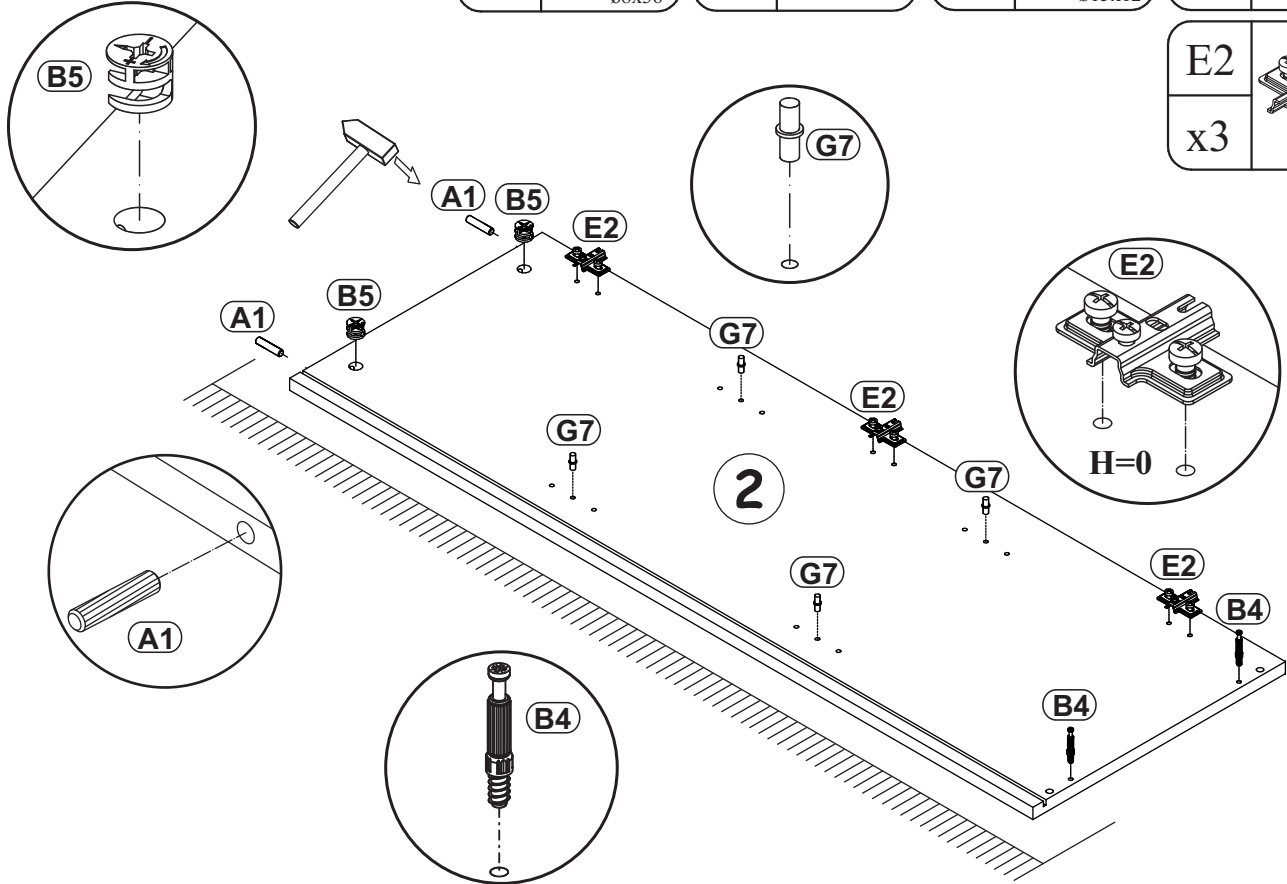
A1		B4		B5		G7	
x2	ø8x36	x2		x2	ø15x12	x4	

E2	
x3	H=0

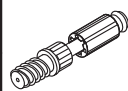

2

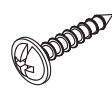
A1		B4		B5	
x1	ø8x36	x2		x1	ø15x12

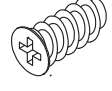
UP13		P2		D20	
x7	UPØ3x16	x7		X2	ESØ6,3x9,5

G31	
X2	

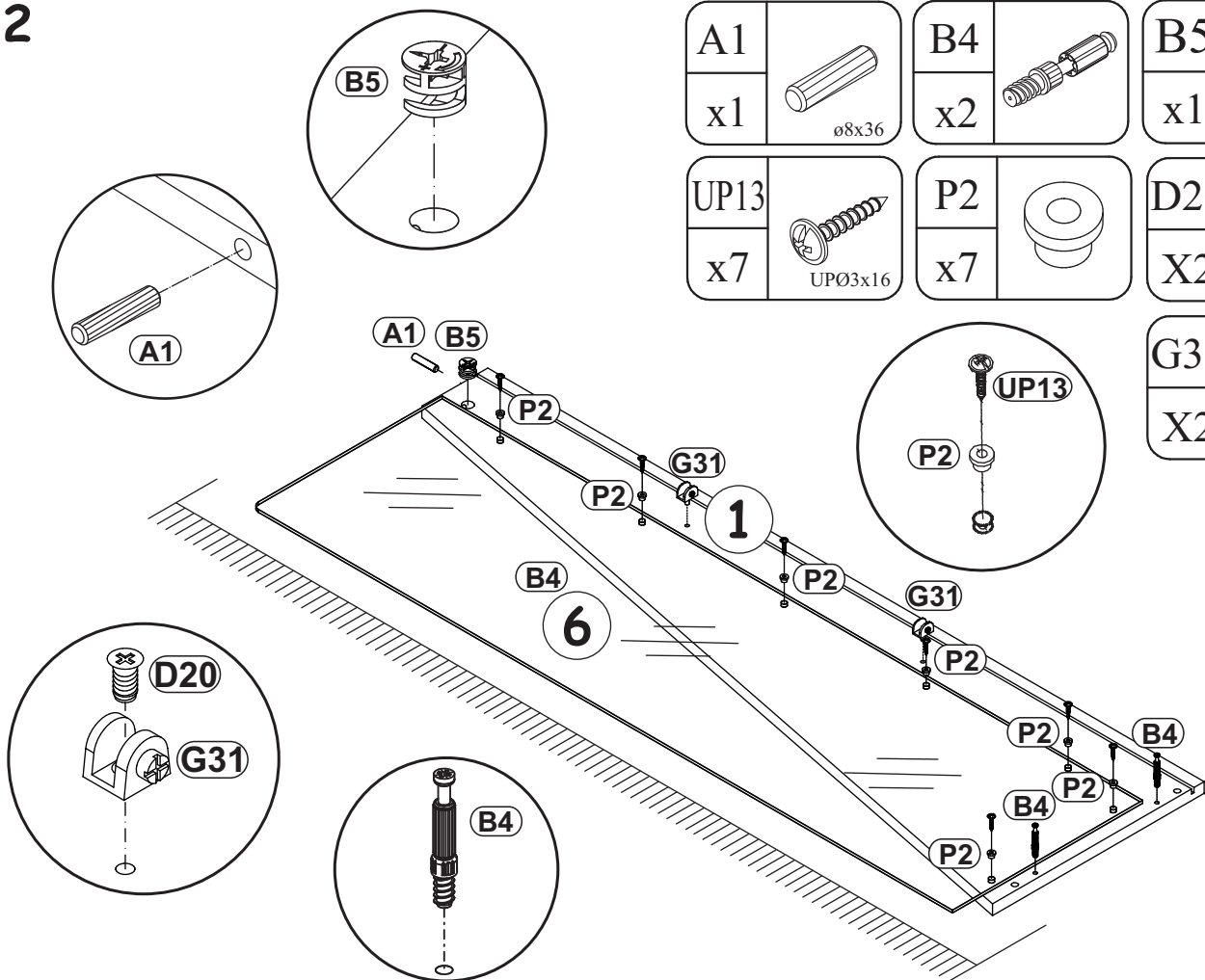

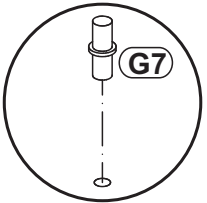
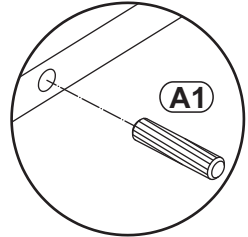
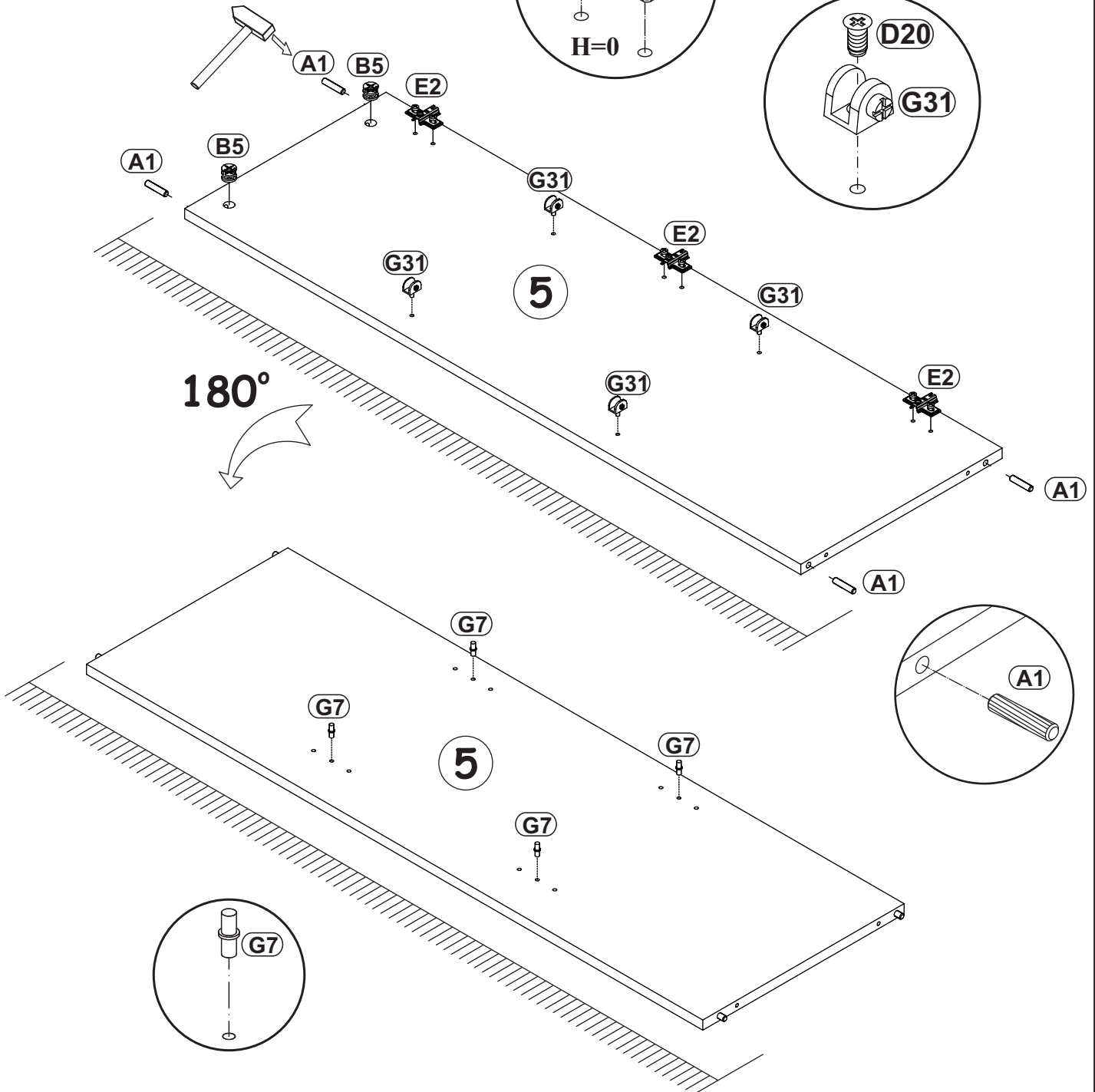
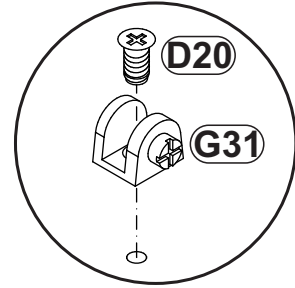
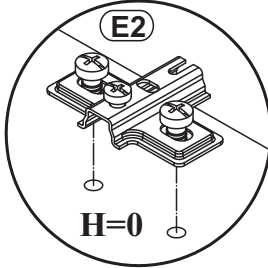
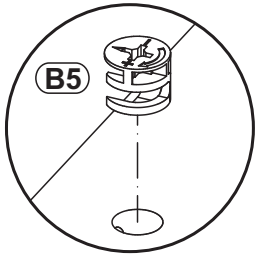
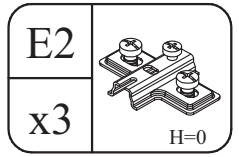
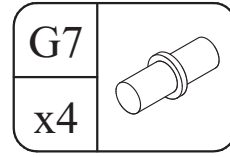
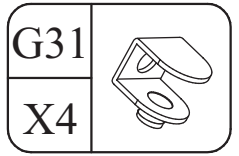
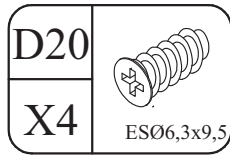
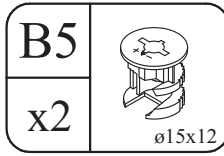
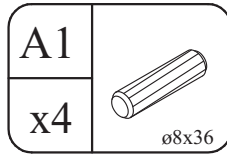

3



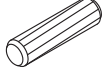

EDGE 29 -- EE WSN

4

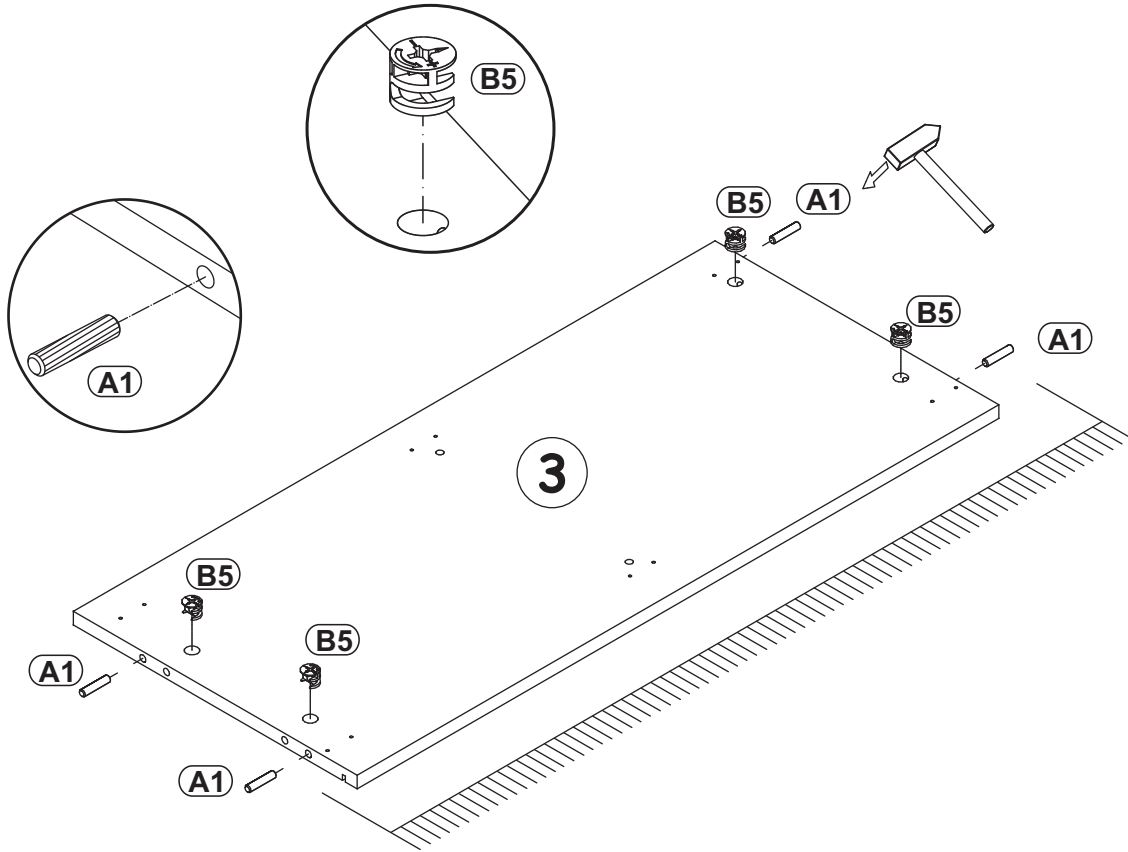
A1		B5	
x4	ø8x36	x4	ø15x12

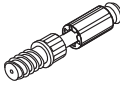

5

B4		UP13		P2	
x5		x4	UPØ3x16	x4	

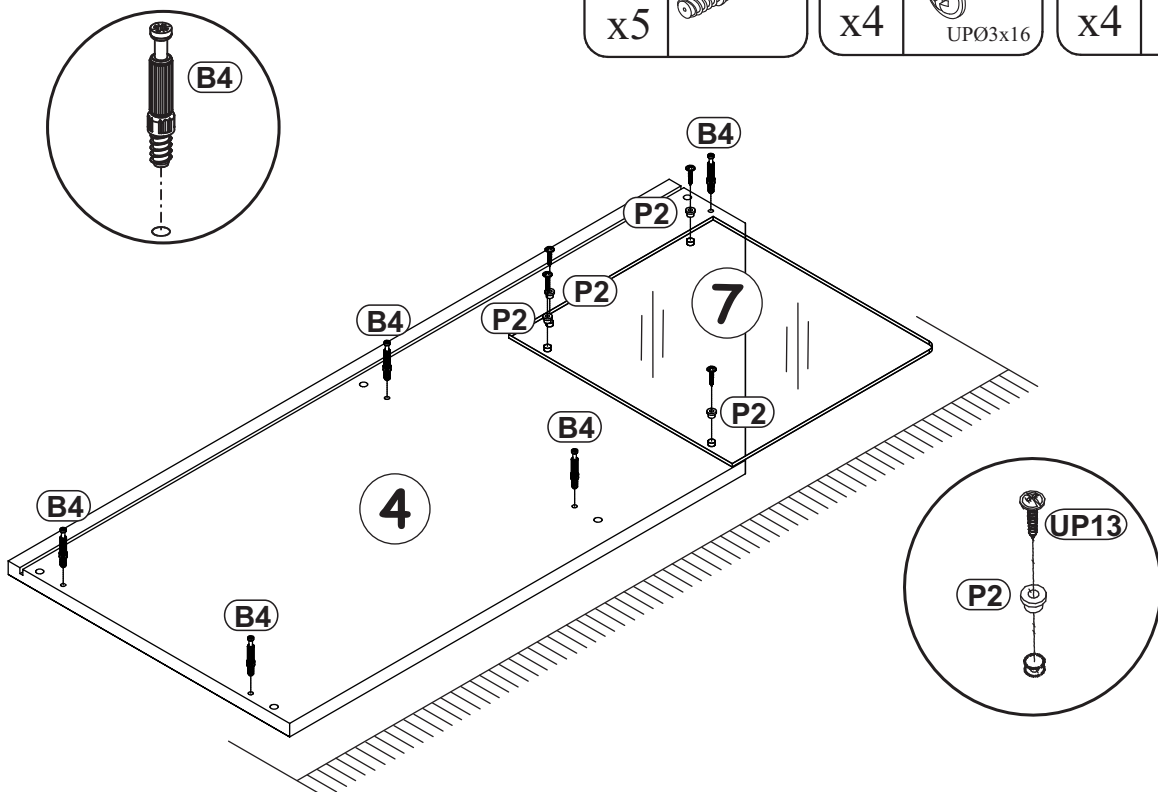

EDGE 29 -- EE WSN

6

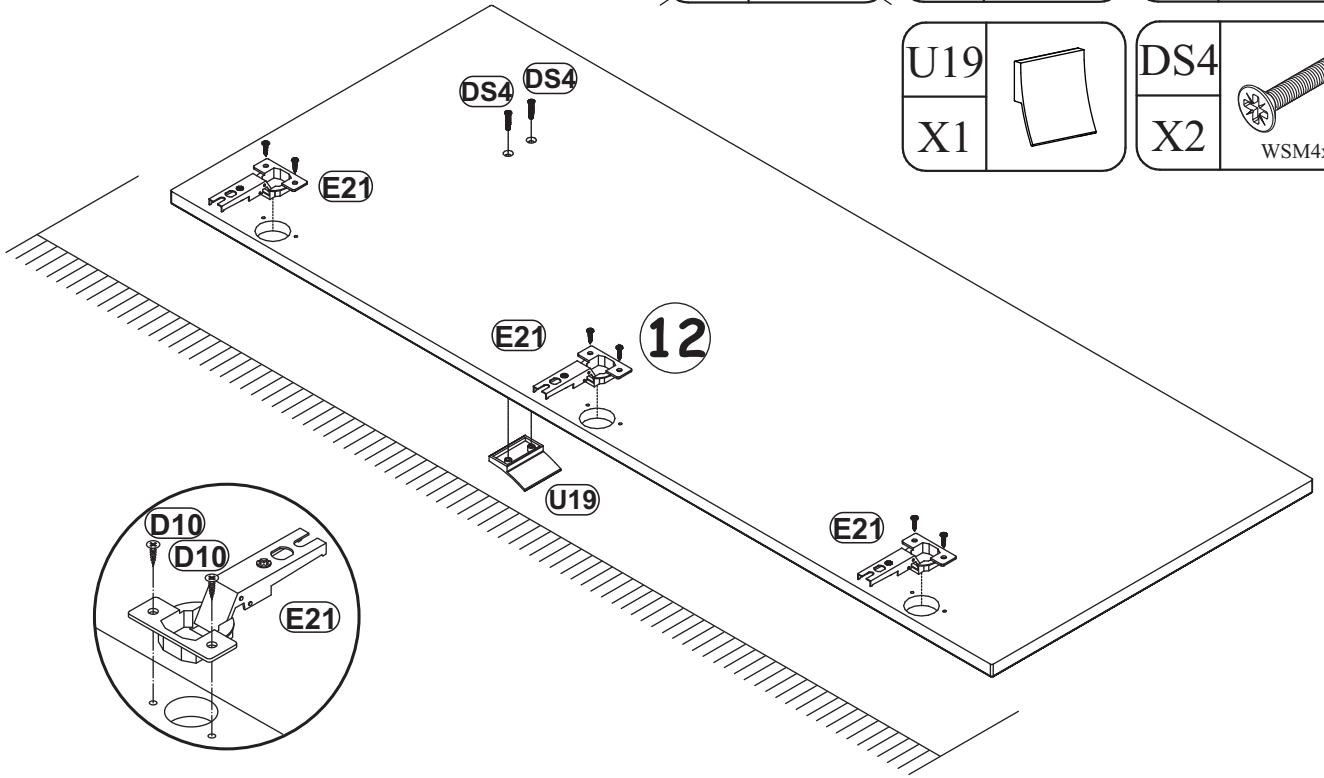
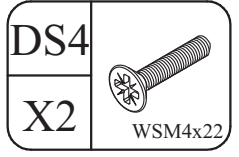
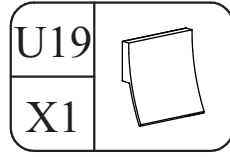
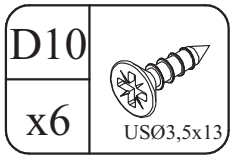
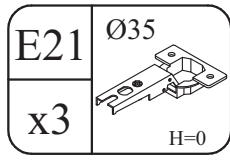
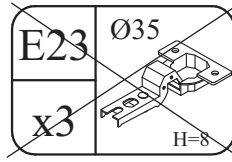

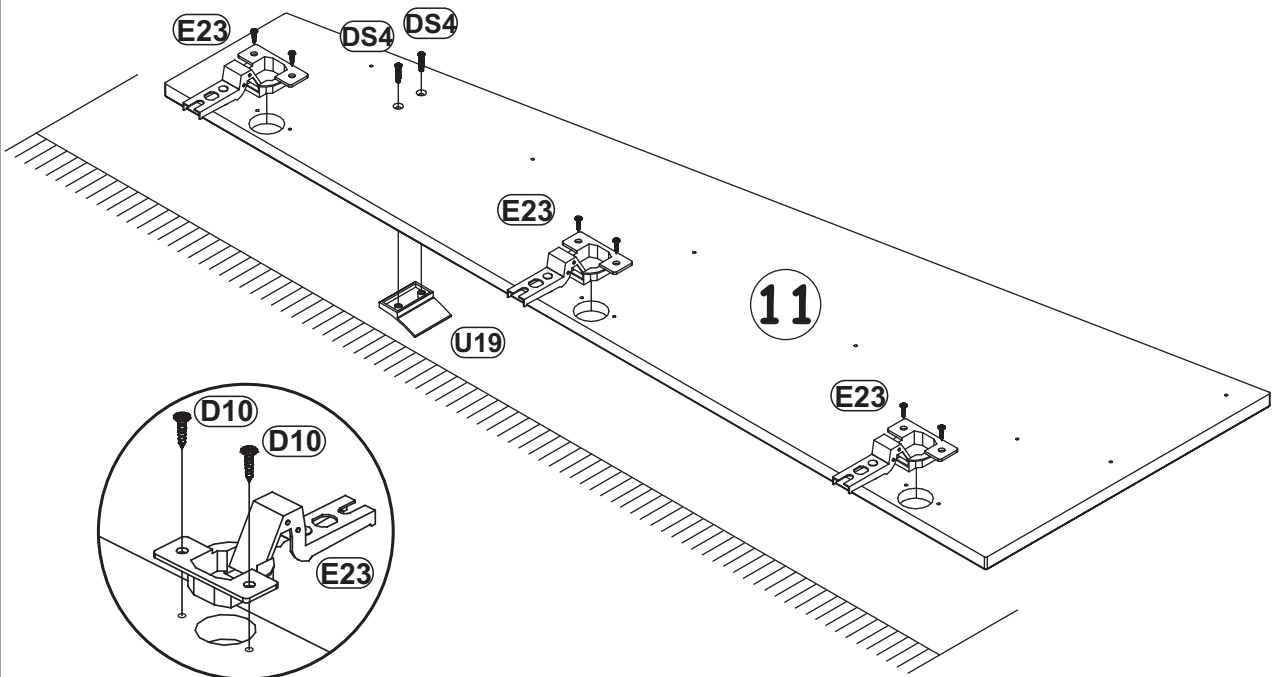
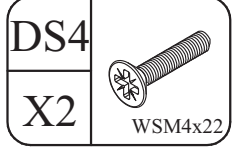
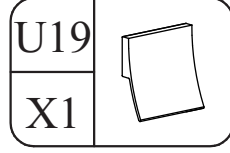
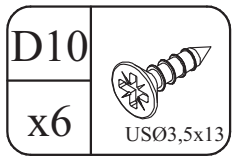
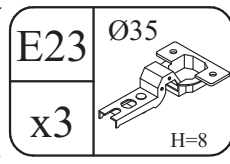
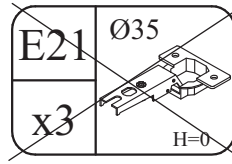

7





EDGE 29 -- EE WSN

8

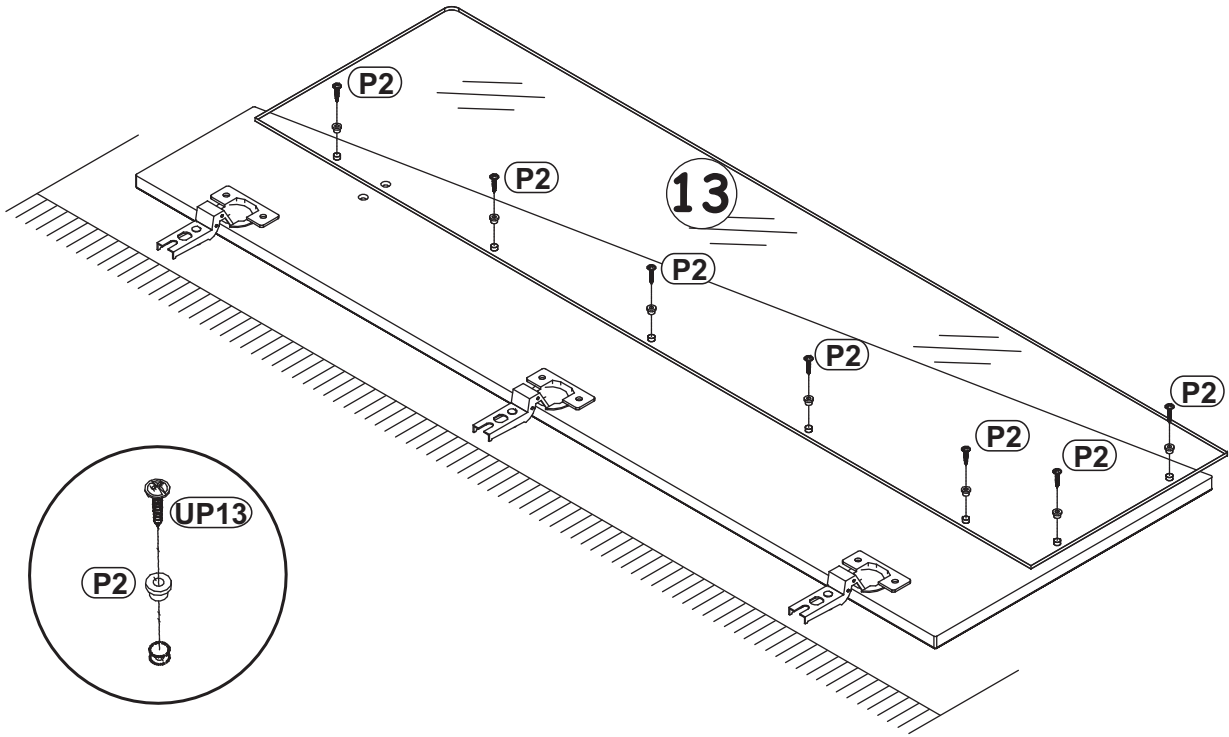
P2		UP13	
x7		x7	UP03x16



9

B11		G4	
x2	Ø7x50	x2	
		G5	
		x4	

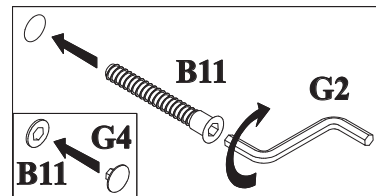
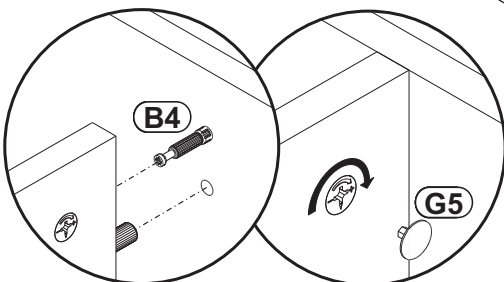
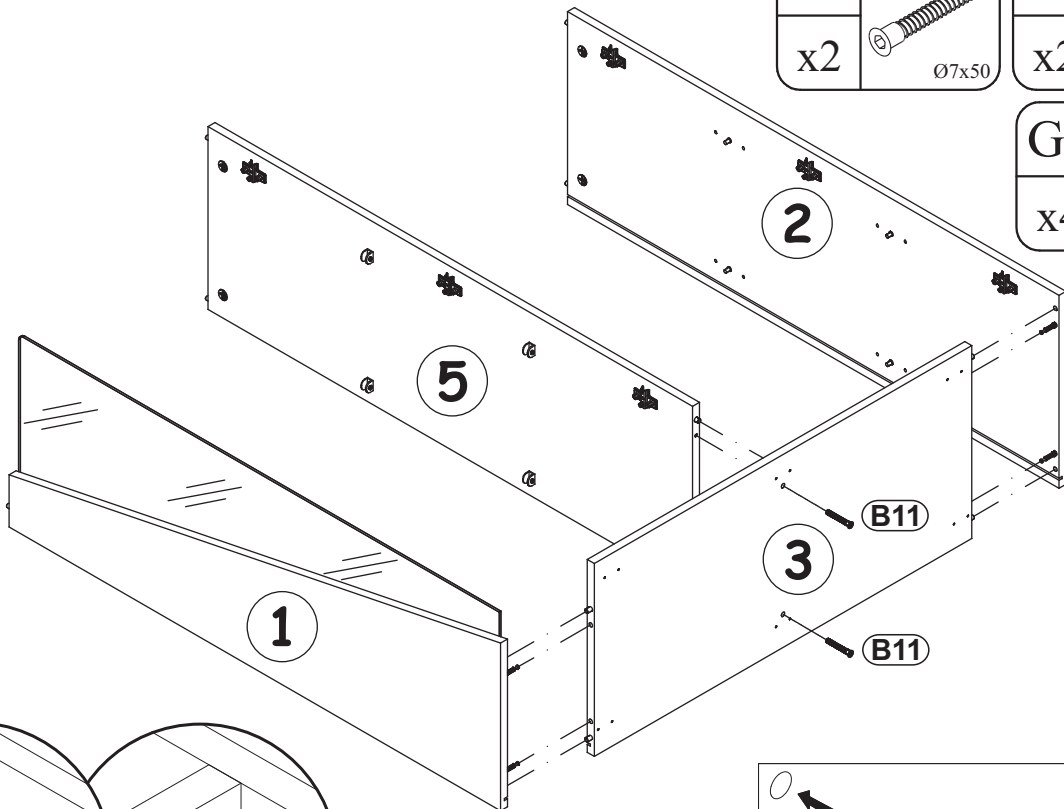

10

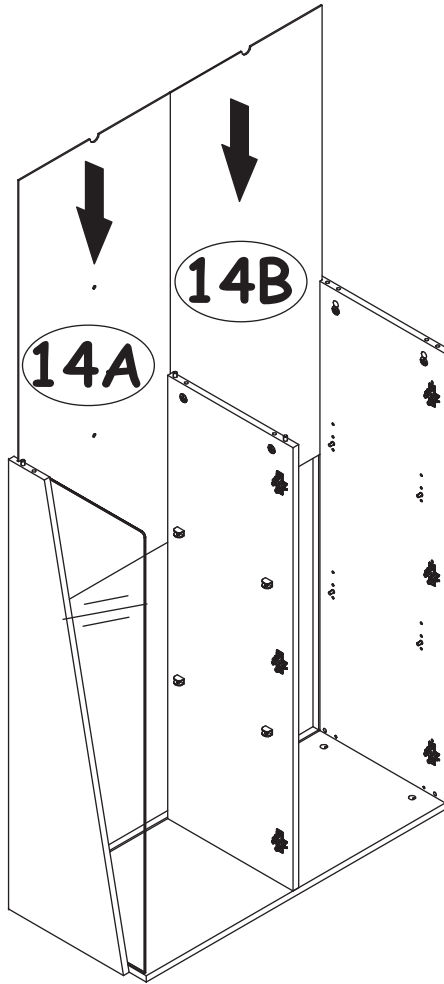

11

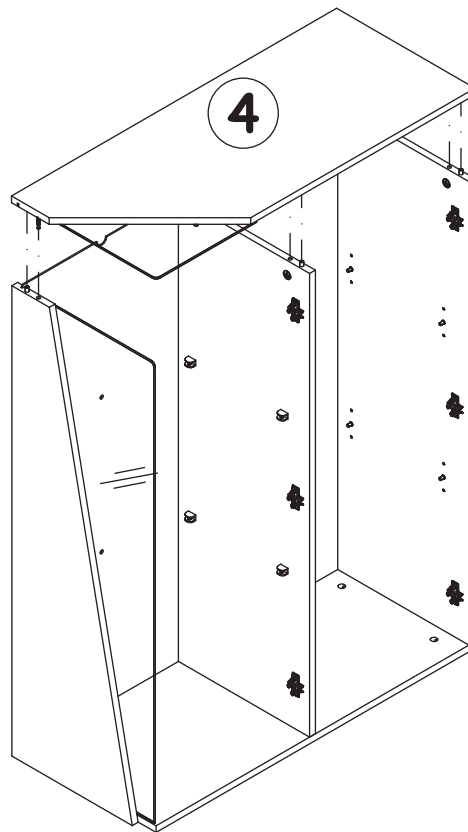
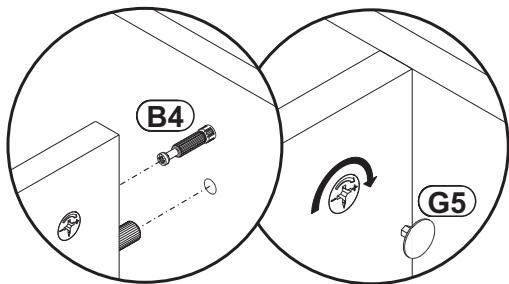
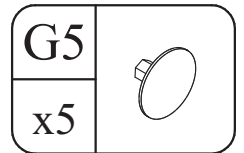

12

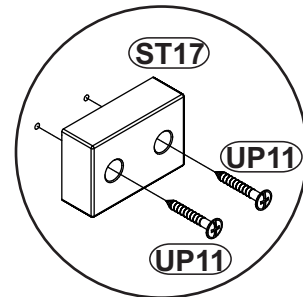
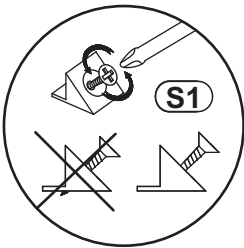
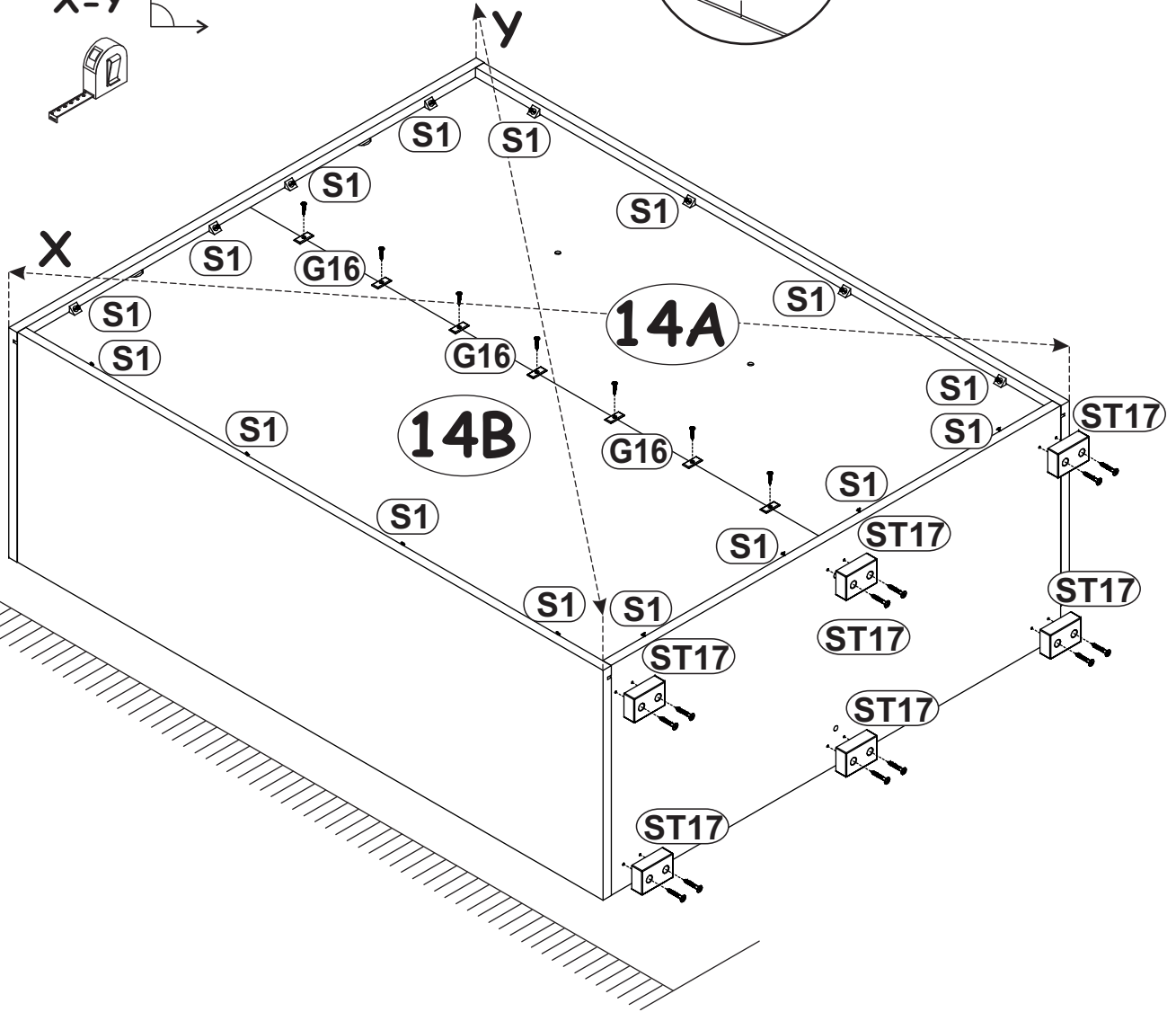
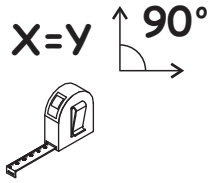
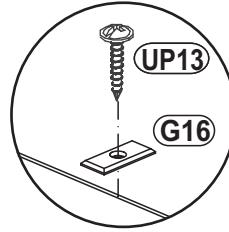
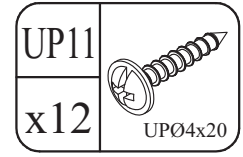
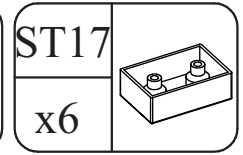
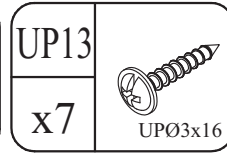
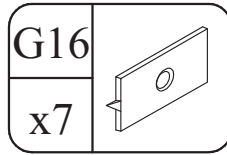
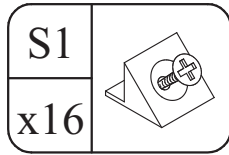

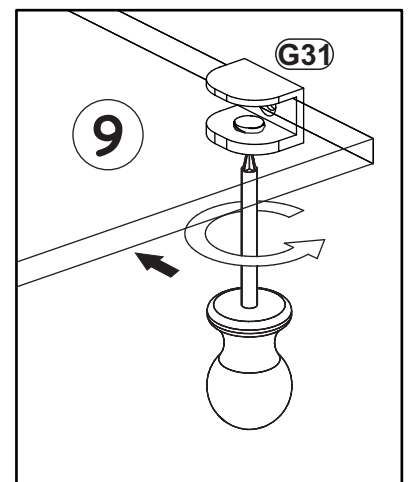
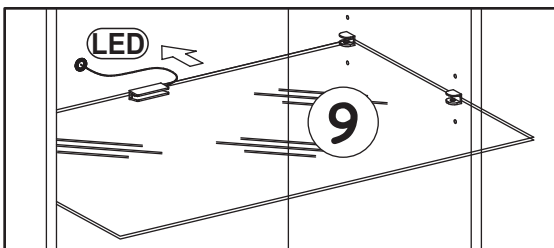
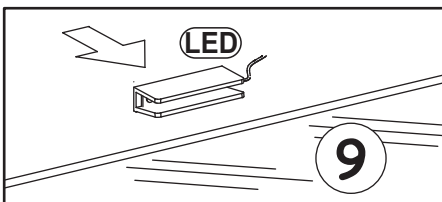
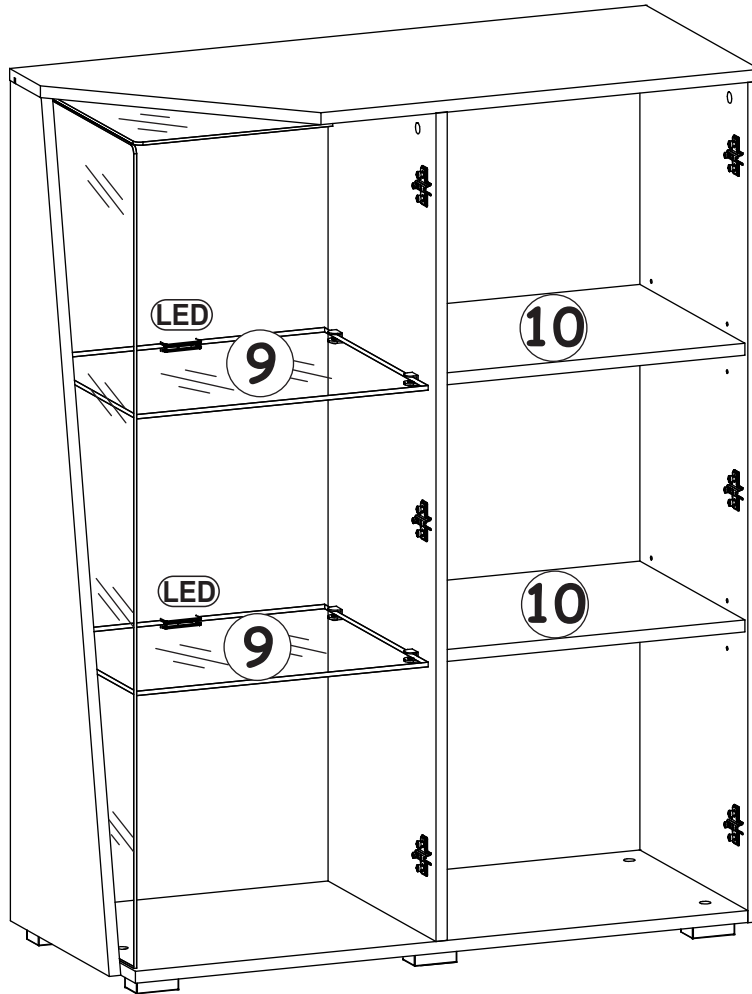
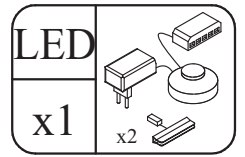

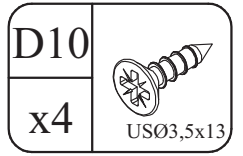
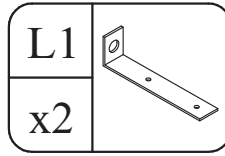
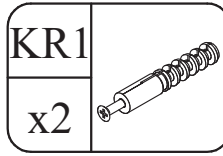

14

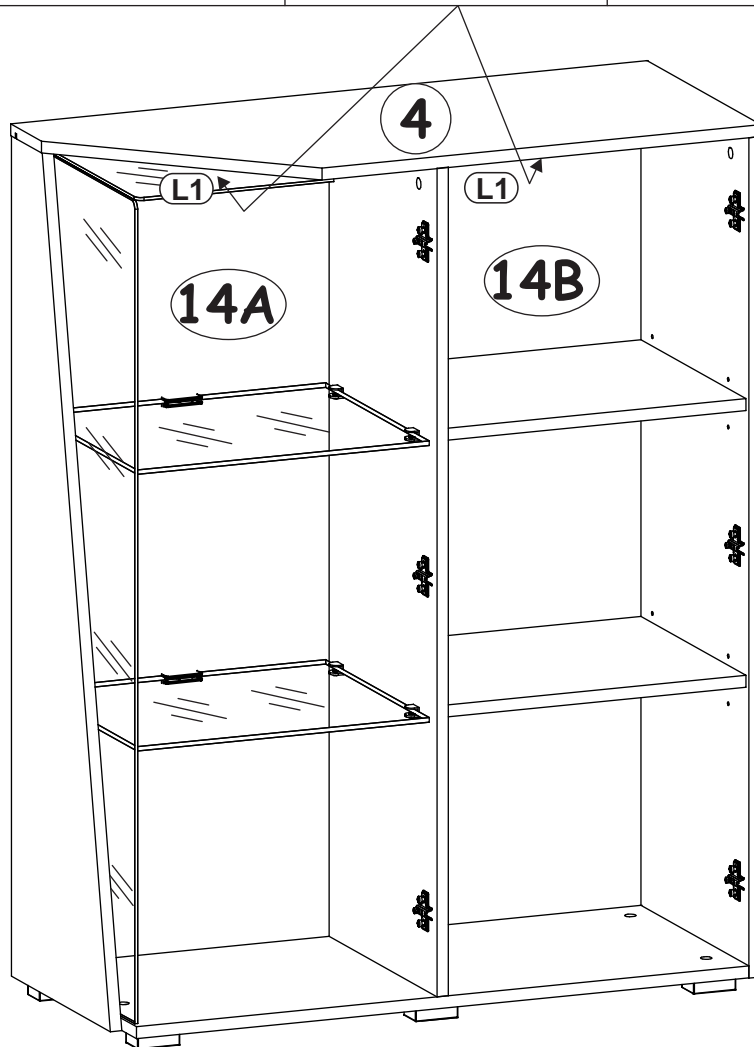
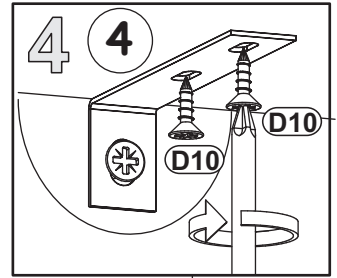
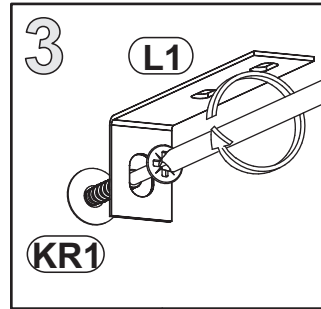
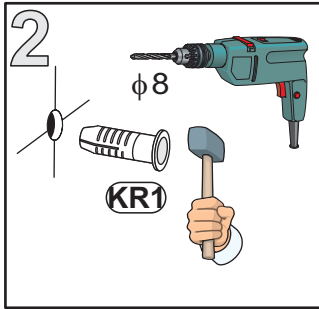
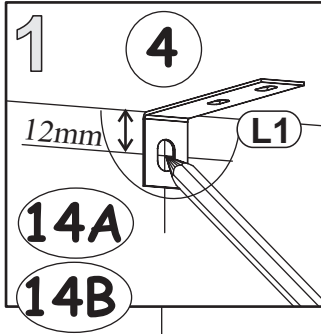
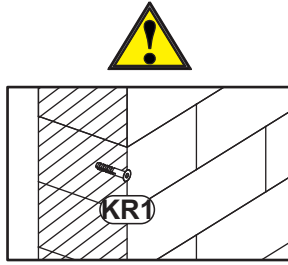
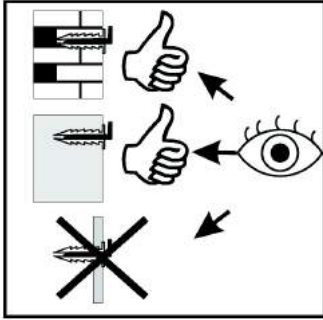

15

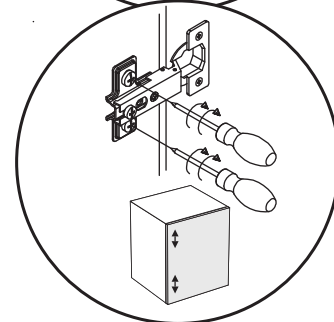
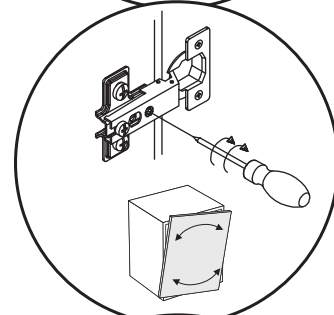
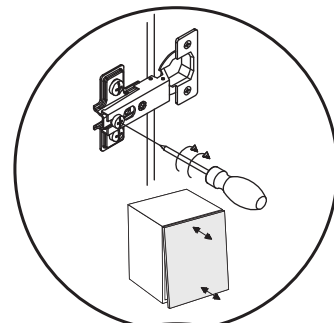
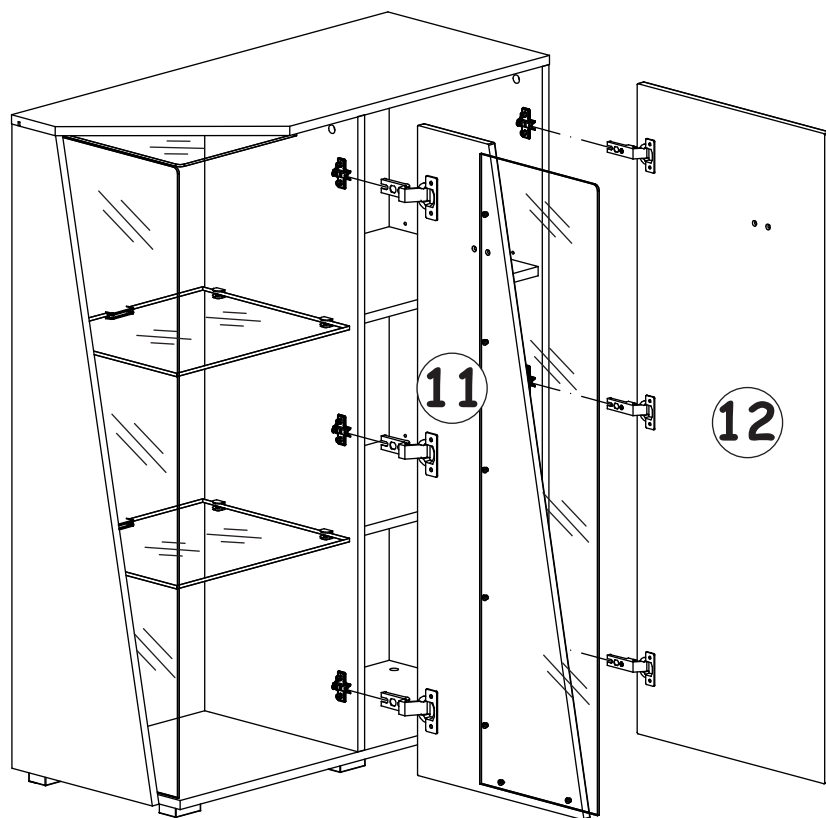

16

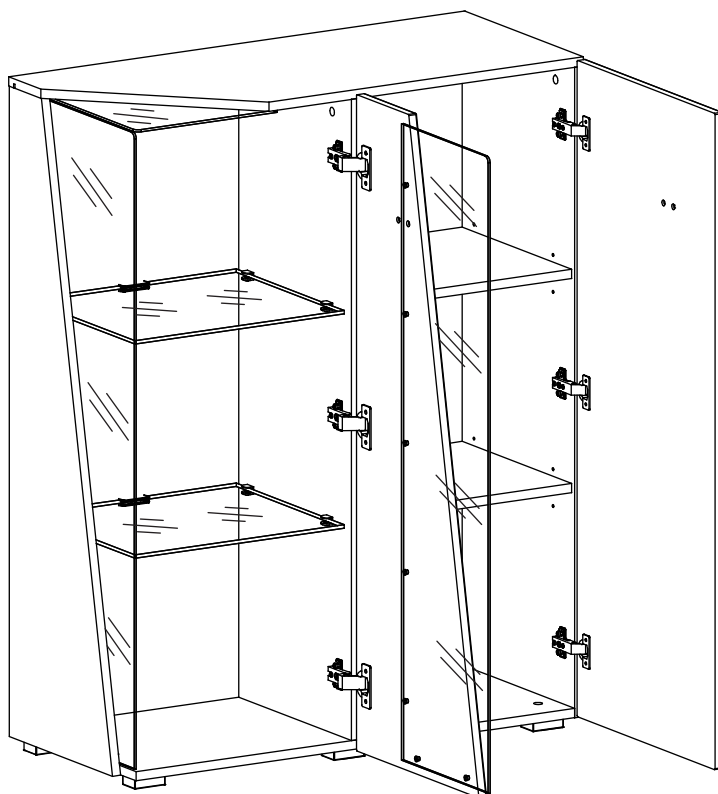

EDGE 29 -- EE WSW

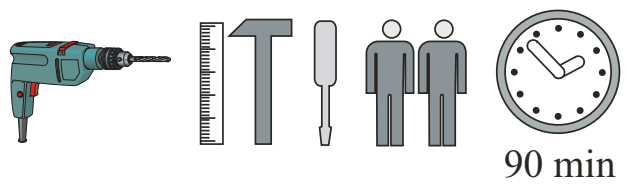
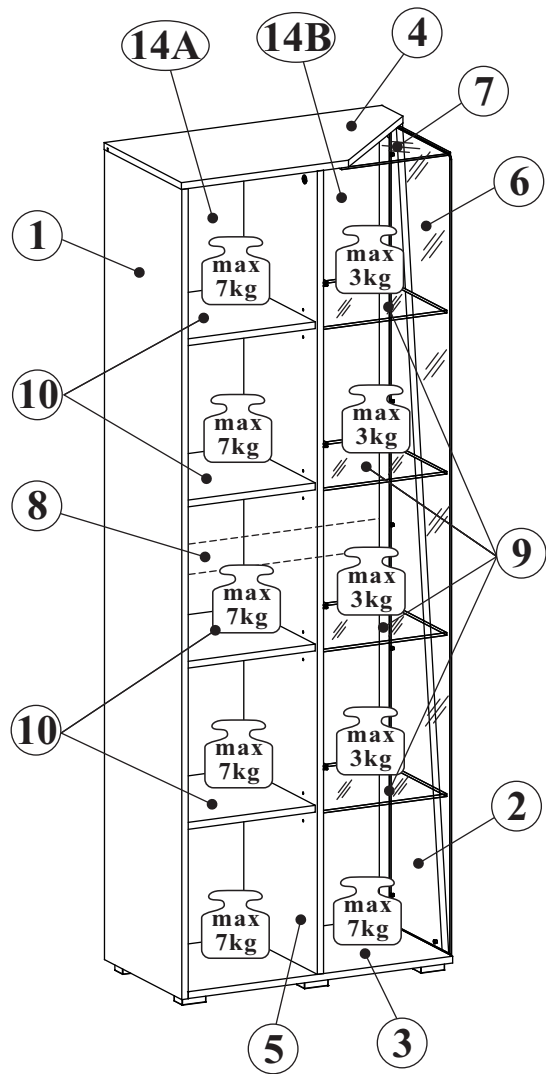
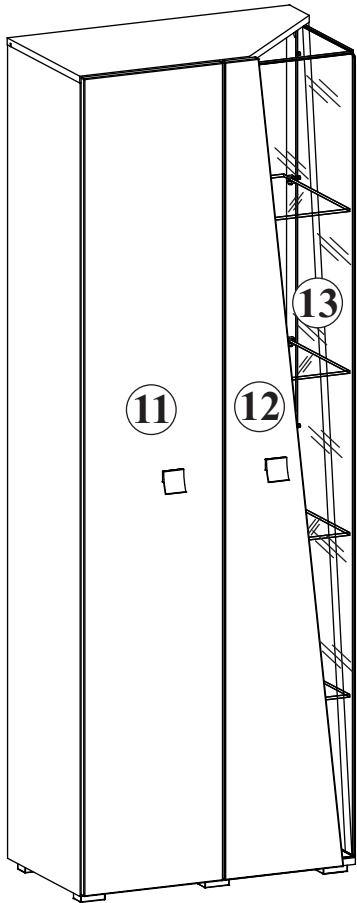

NO	Dim.			Col.-No	Qty
1	1890	384	16	2	1
2	1890	334	16	2	1
3	668	384	16	1	1
4	702	384	16	1	1
5	1874	364	16	2	1
6	1865	300	4	3	1
7	305	279	4	1	1
8	668	80	16	2	1
9	314	349	6	1	4
10	326	354	16	1	4
11	346	1900	16	3	1
12	296	1900	16	3	1
13	1865	280	4	3	1
14A	1885	341	3	3	1
14B	1885	341	3	3	1

EDGE 29 -- EE WSW

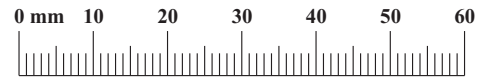

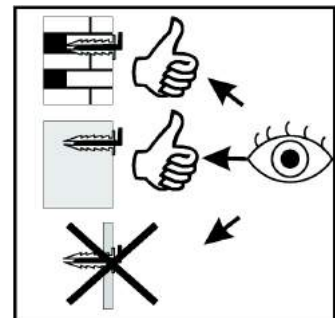
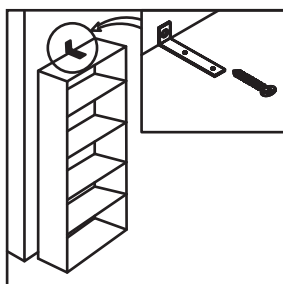
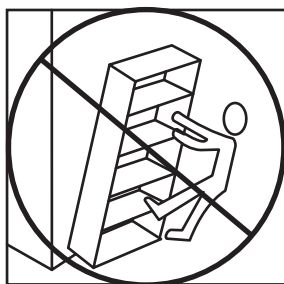
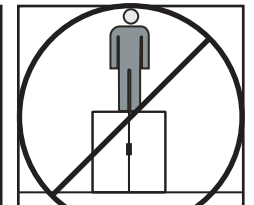
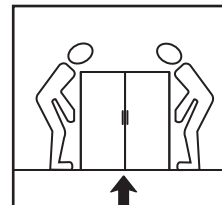
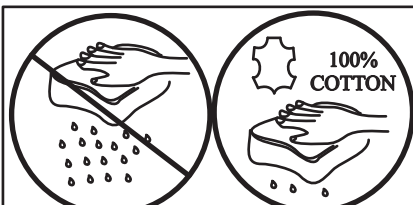
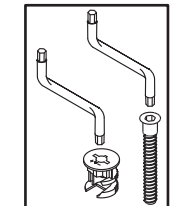
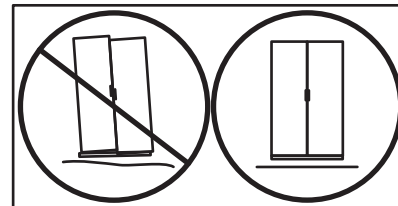
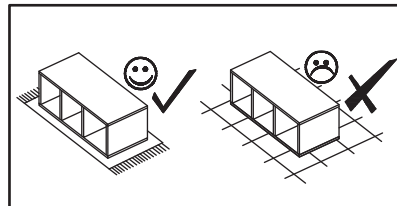
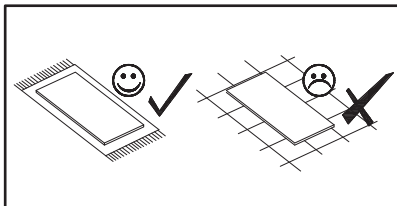
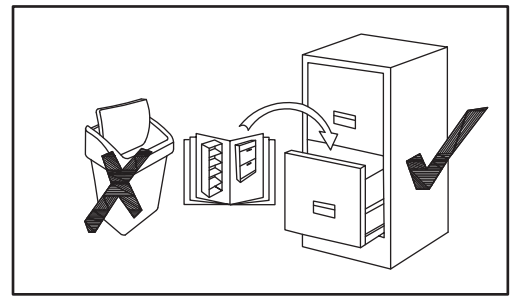
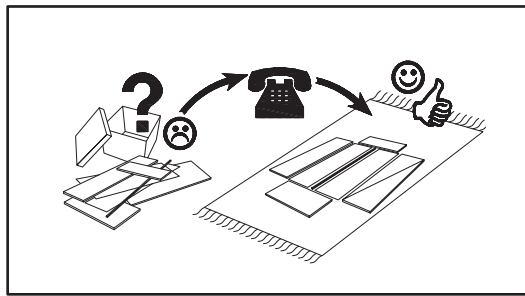
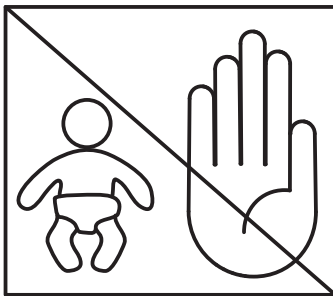

A1 x13 ø8x36	B4 x11	B5 x11 ø15x12	G5 x11	B11 x2 ø7x50	G4 x2
E21 x4 Ø35 H=0	E23 x4 Ø35 H=8	E2 x8 H=0	D10 x18 USØ3,5x13	G7 x16	G31 x12
ST17 x6	UP11 x12 UPØ4x20	G16 x12	UP13 x34 UPØ3x16	P2 x22	D20 x12 ESØ6,3x9,5
U19 x2	DS4 x4 WSM4x22	S1 x18	LED x1 x4	KR1 x1	L1 x1
G2 x1					



EDGE 29 -- EE WSW

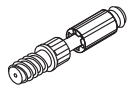

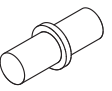
1

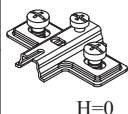
A1		B4		B5		G7	
x2	ø8x36	x3		x2	ø15x12	x8	

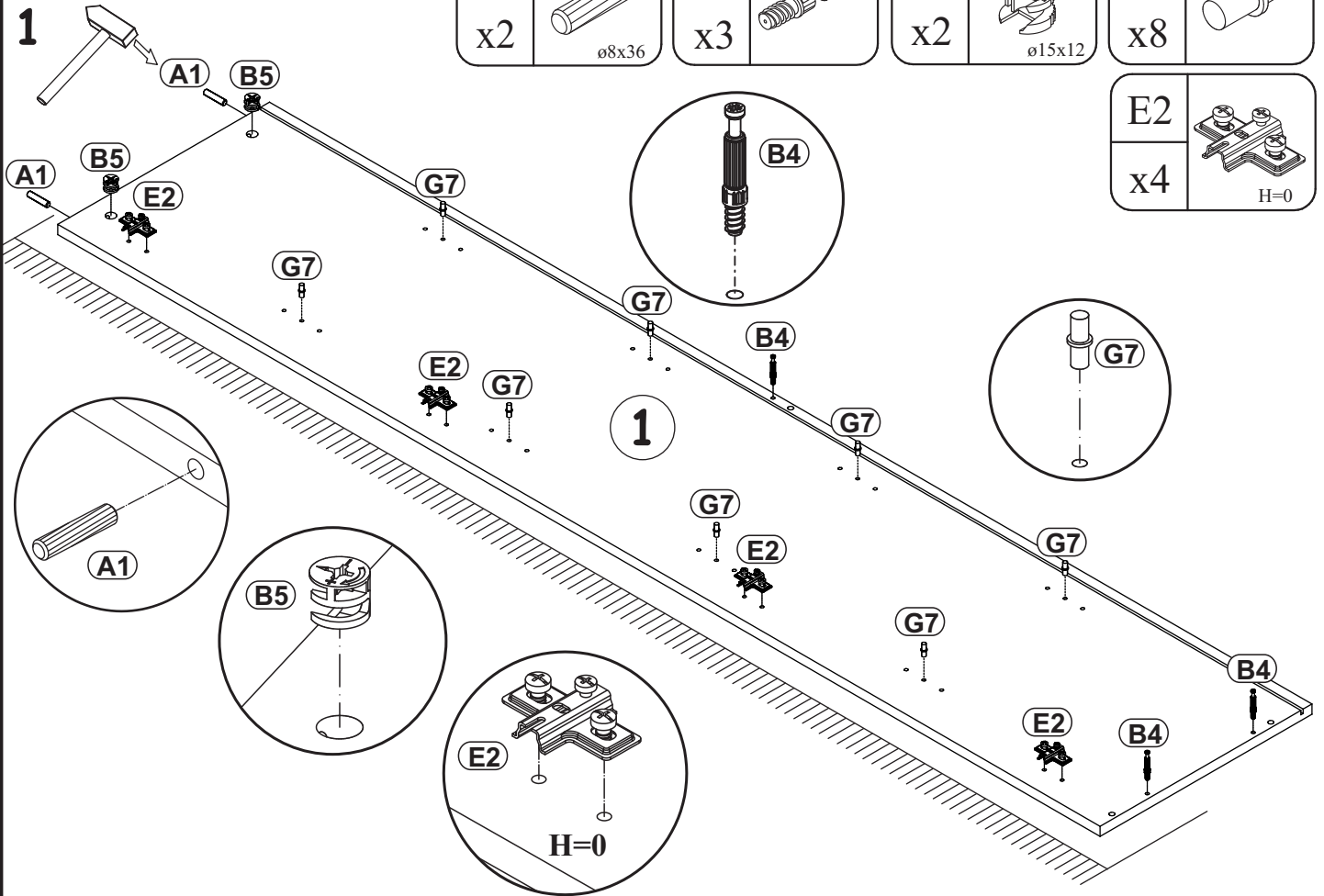
E2	
x4	H=0

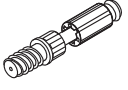

2

A1		B4		B5		P2	
x1	ø8x36	x3		x1	ø15x12	x9	

UP13		G31	
x9	UPØ3x16	x4	

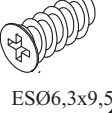
D20	
x4	ESØ6,3x9,5

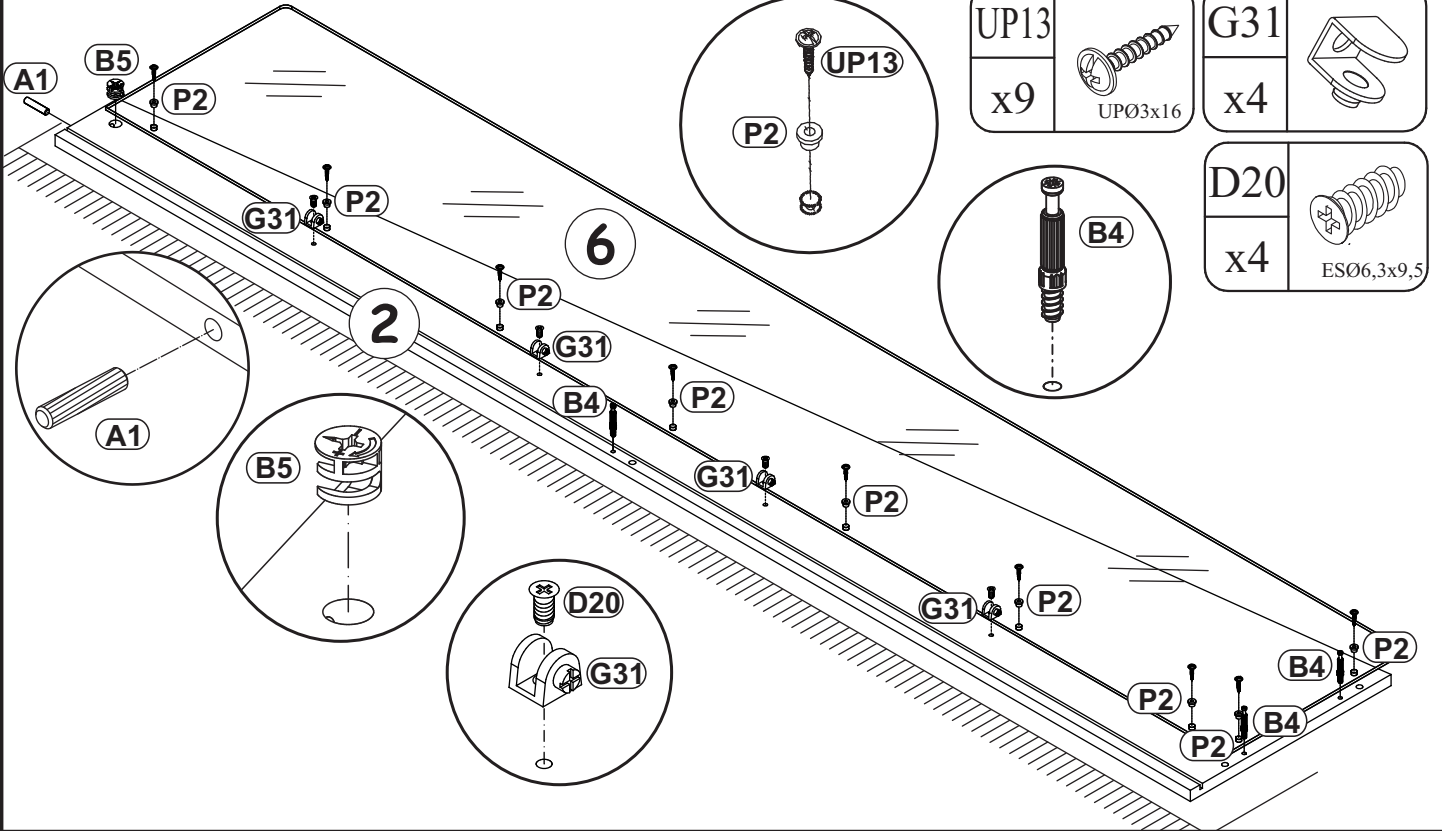

EDGE 29 -- EE WSW

3

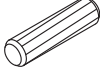
A1	
x4	ø8x36

B5	
x2	ø15x12

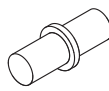
G7	
x8	

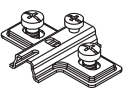
E2	
x4	H=0

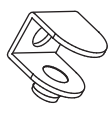

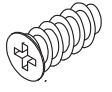
G31	
x8	

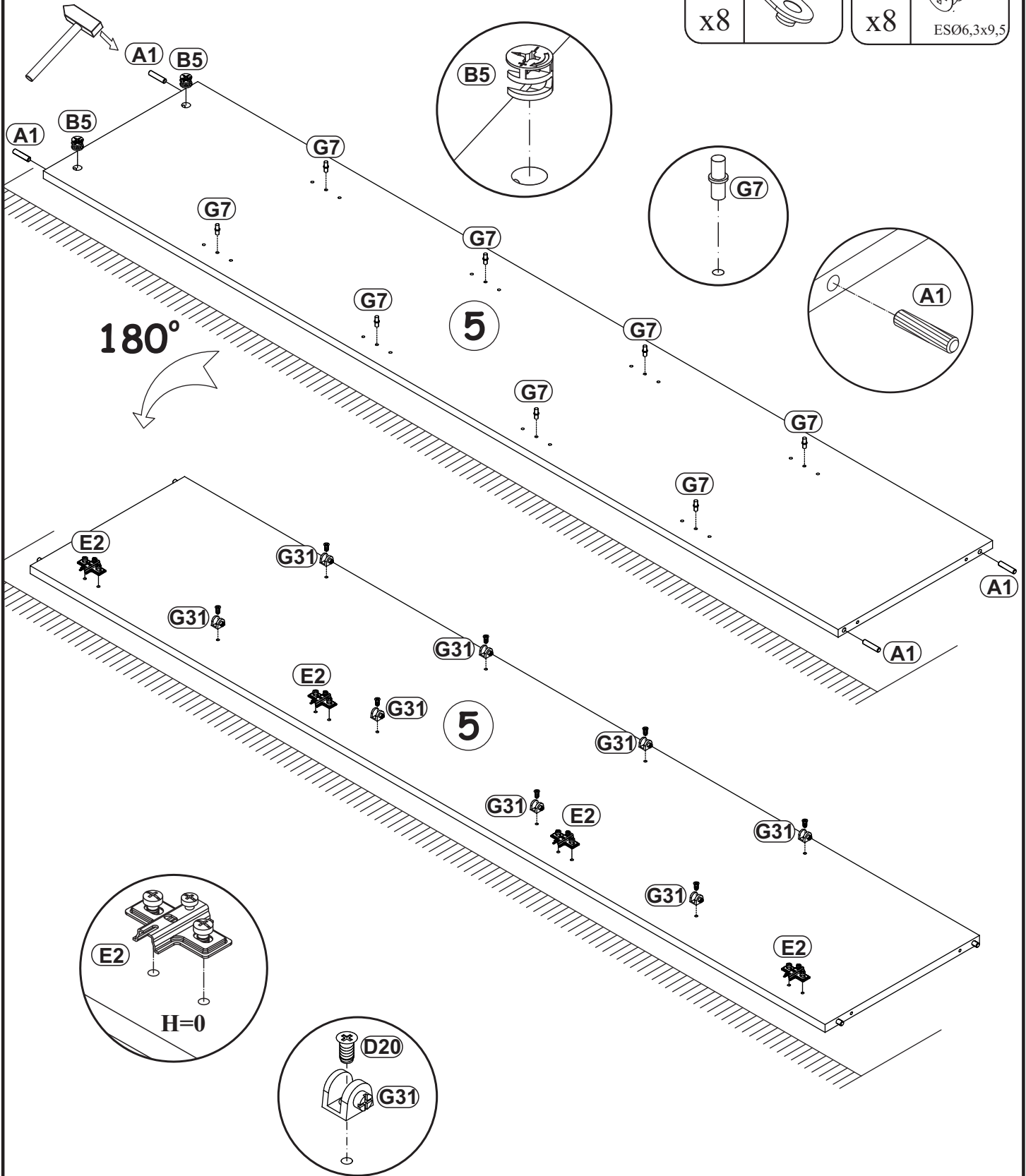
D20	
x8	ES06,3x9,5



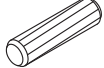

EDGE 29 -- EE WSW

4

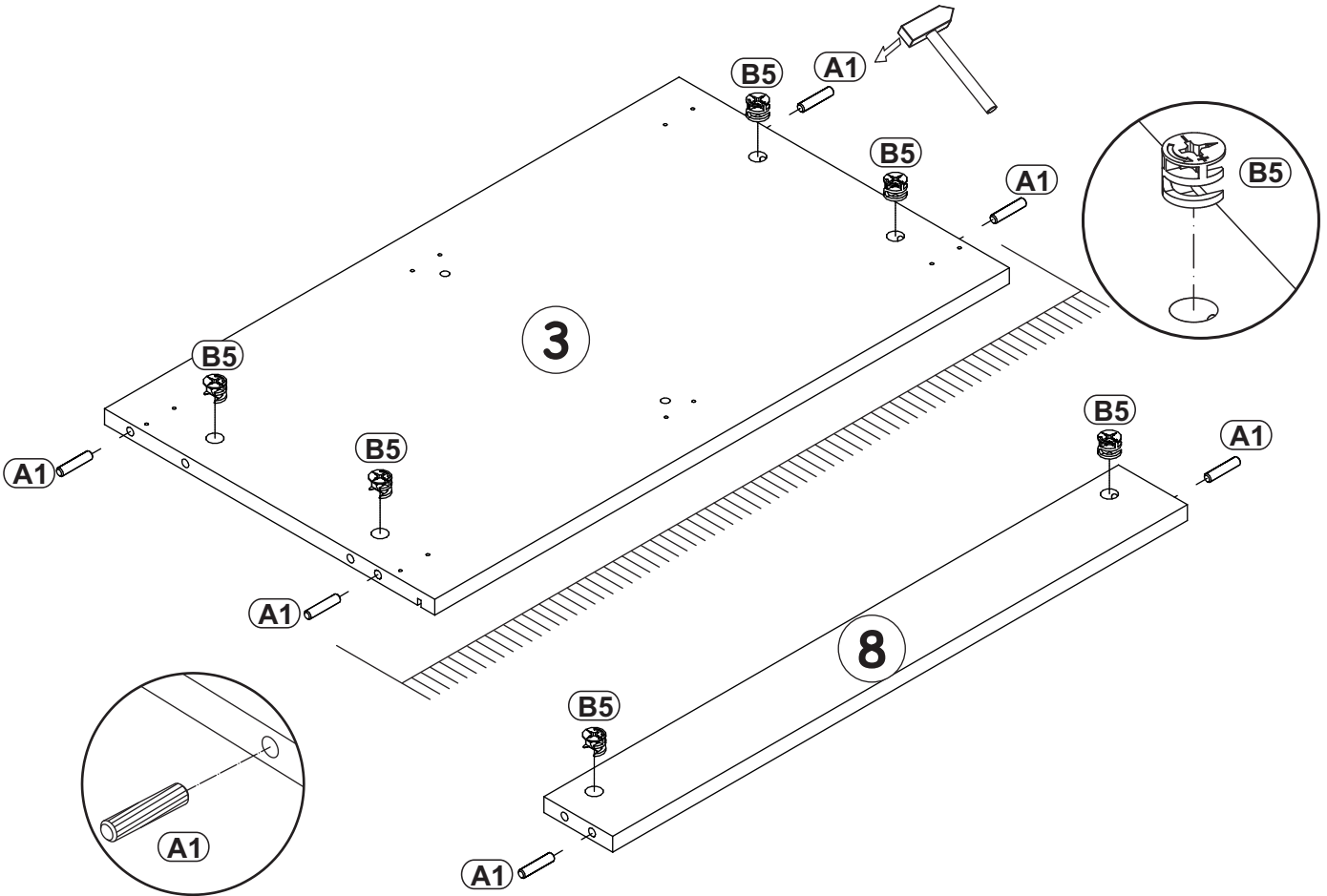
A1		B5	
x6	ø8x36	x6	ø15x12

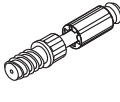

5



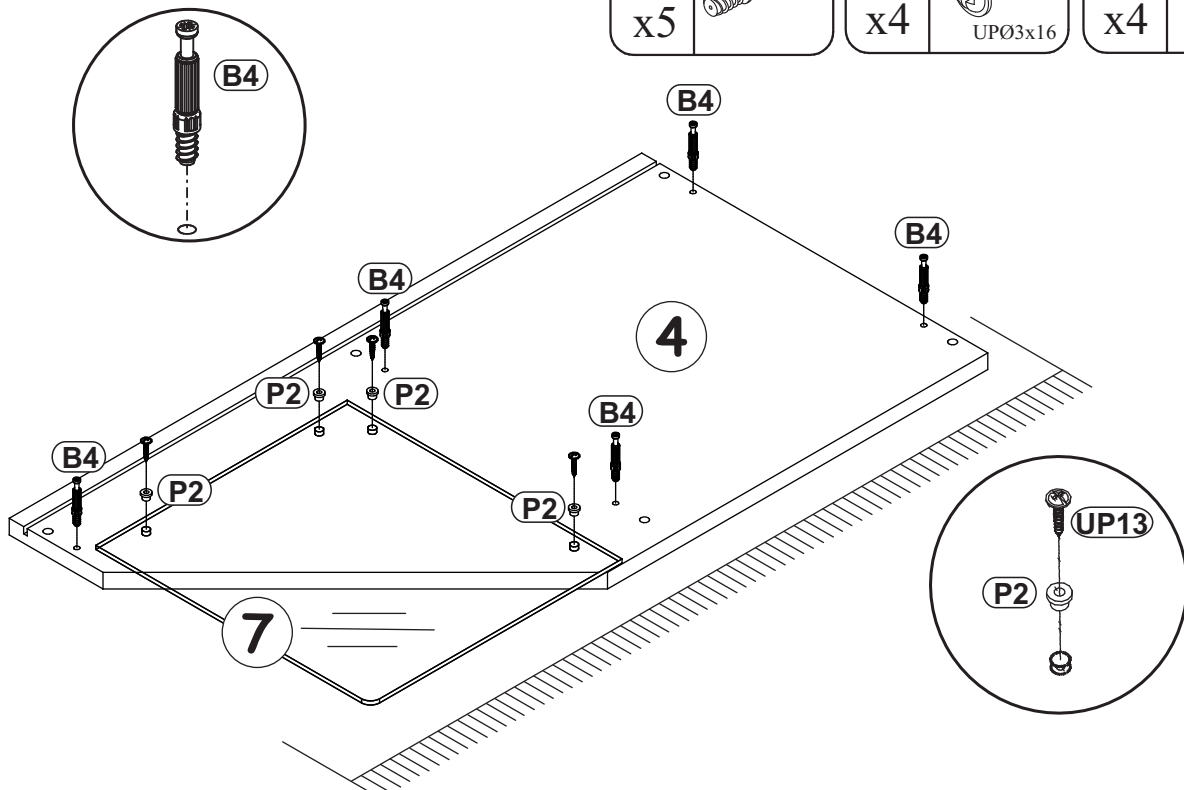

B4		UP13		P2	
x5		x4	UPØ3x16	x4	

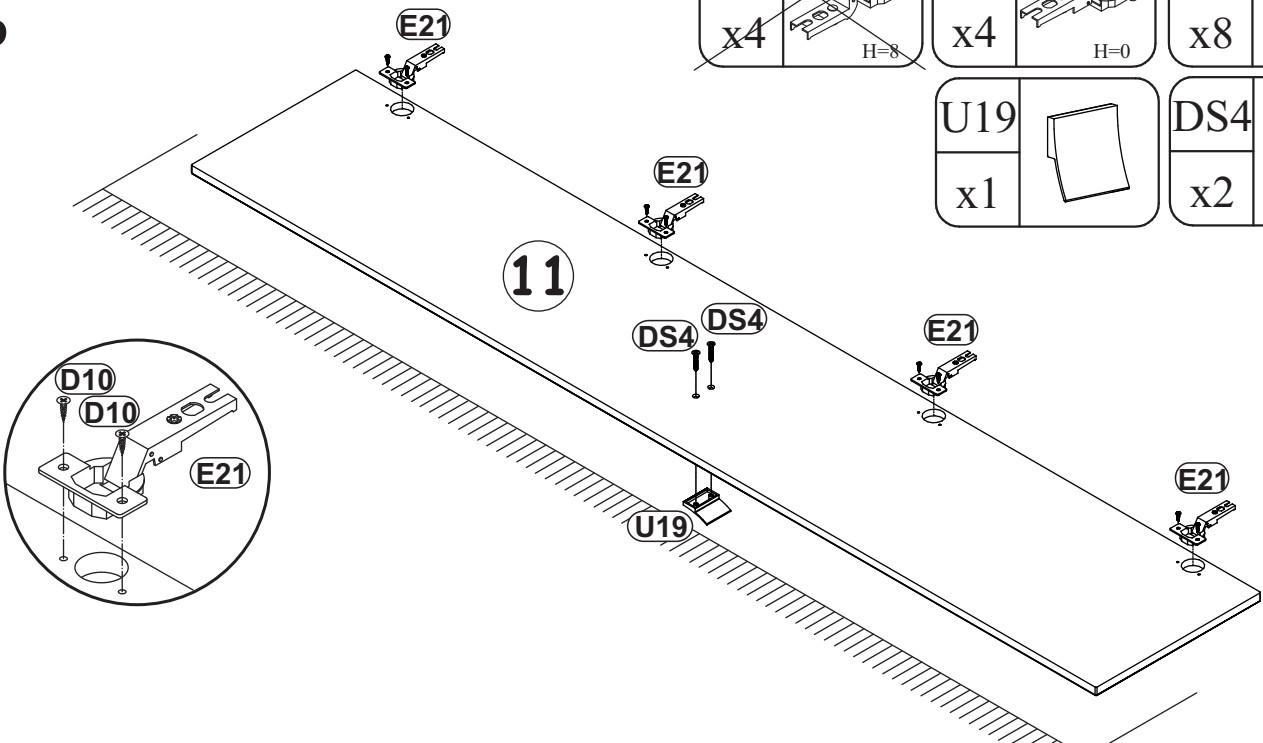

EDGE 29 -- EE WSW

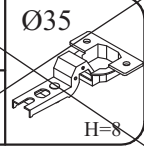
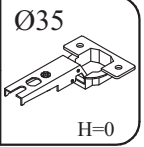

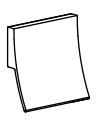

6

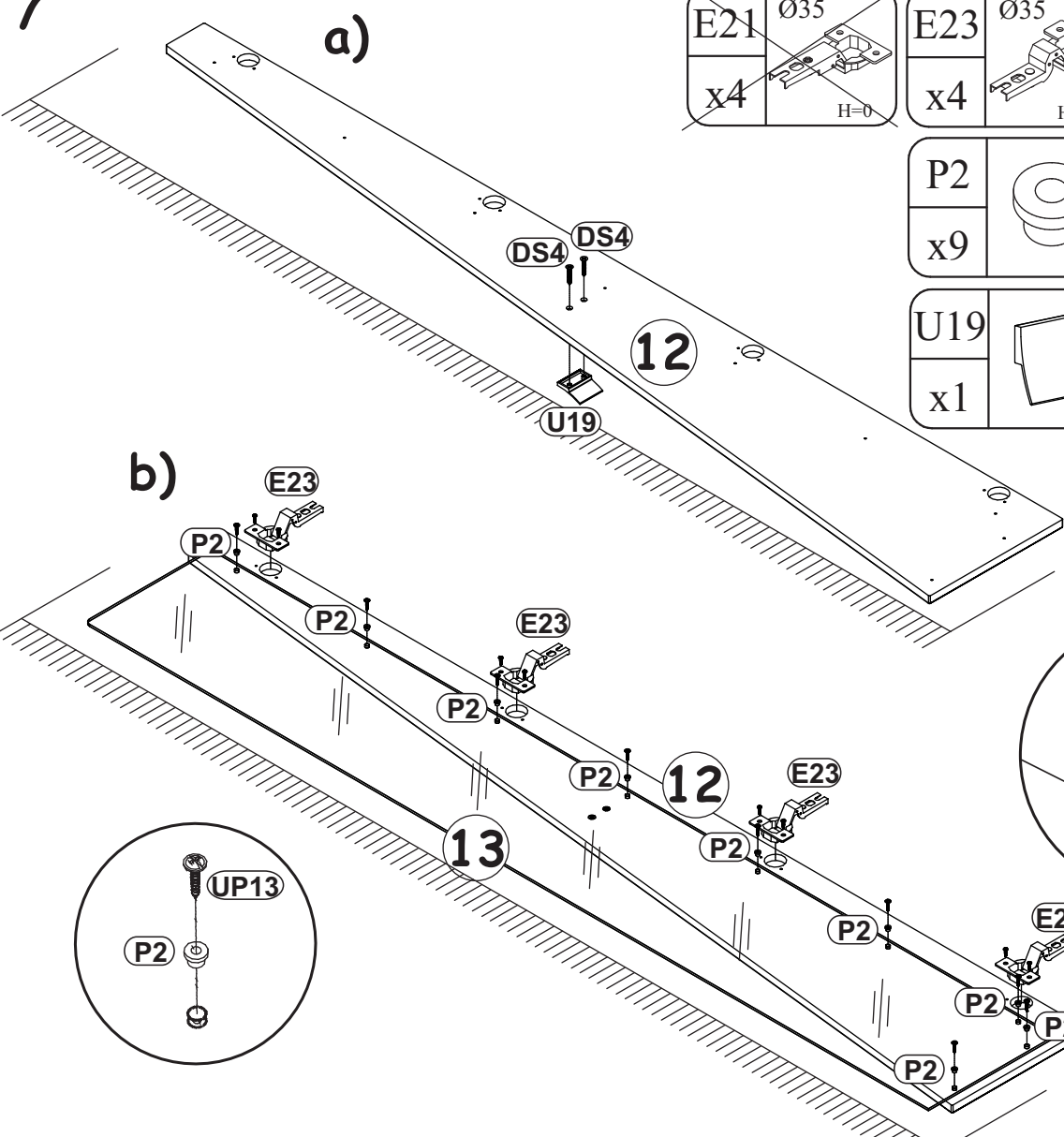

E23 x4	 Ø35 H=8	E21 x4	 Ø35 H=0	D10 x8	 USØ3,5x13
U19 x1		DS4 x2	 WSM4x22		

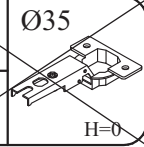
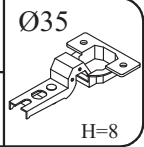
7

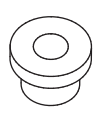

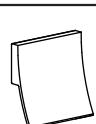
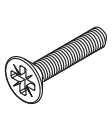

E21 x4	 Ø35 H=0	E23 x4	 Ø35 H=8	D10 x8	 USØ3,5x13
P2 x9		UP13 x9	 UPØ3x16		
U19 x1		DS4 x2	 WSM4x22		

G5	
x6	

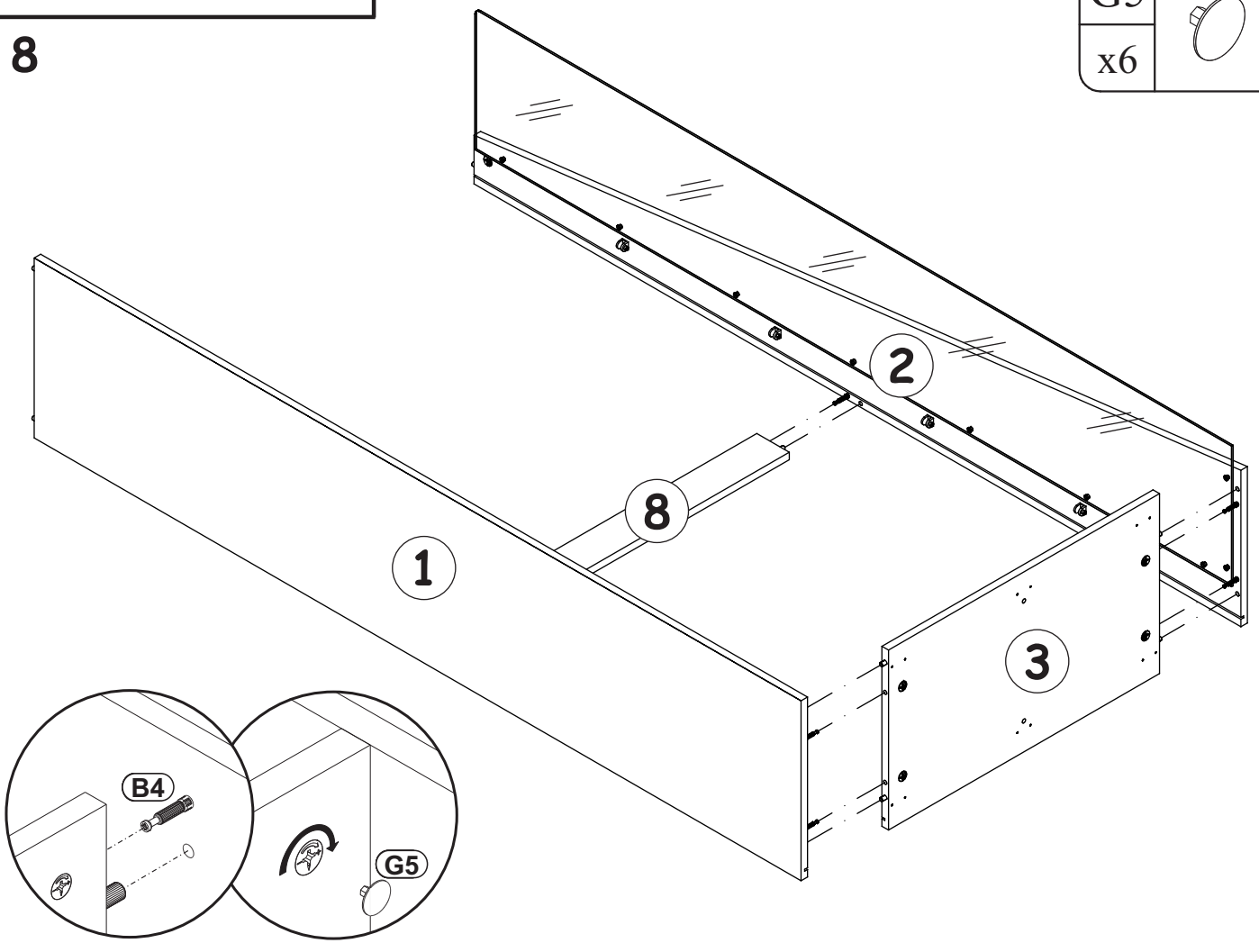
8



9

B11		G4	
x2	Ø7x50	x2	

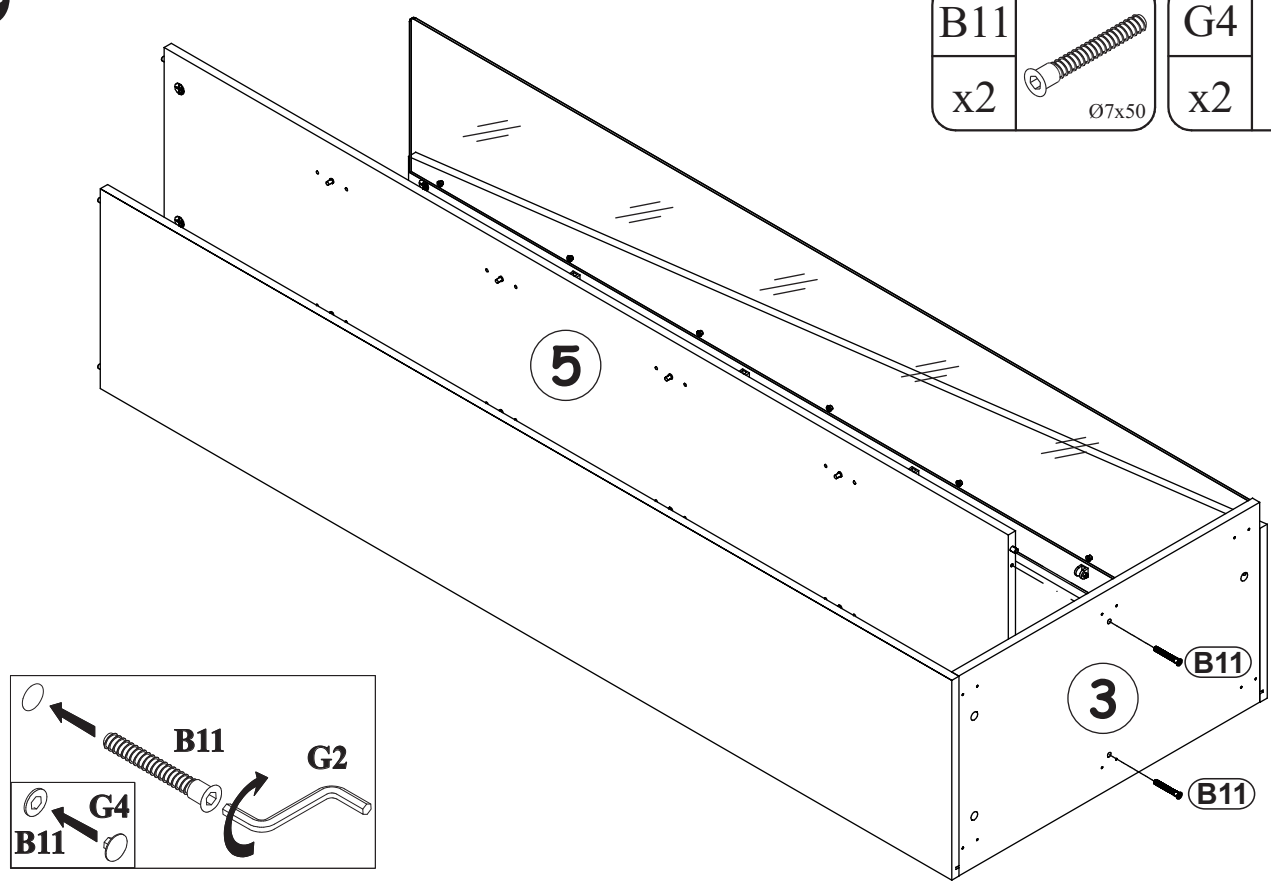

10

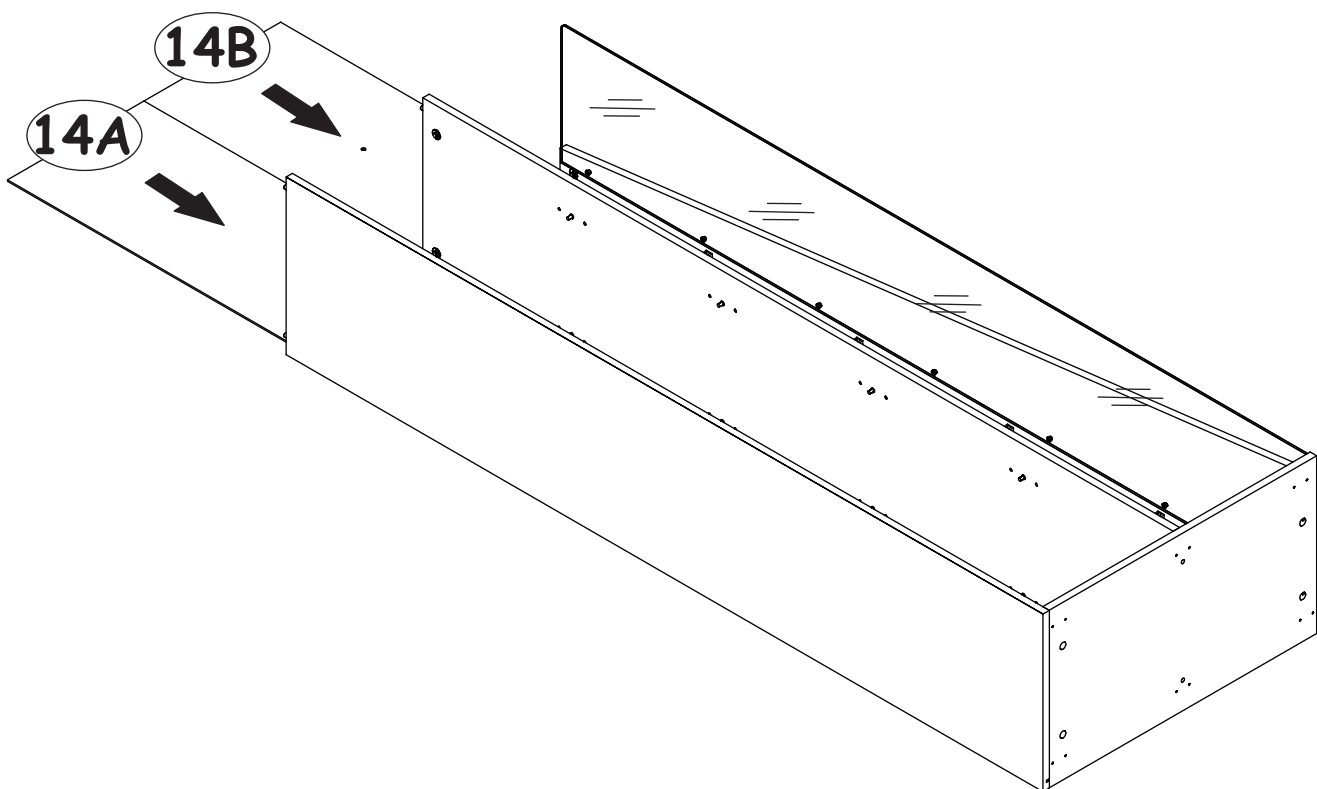

11

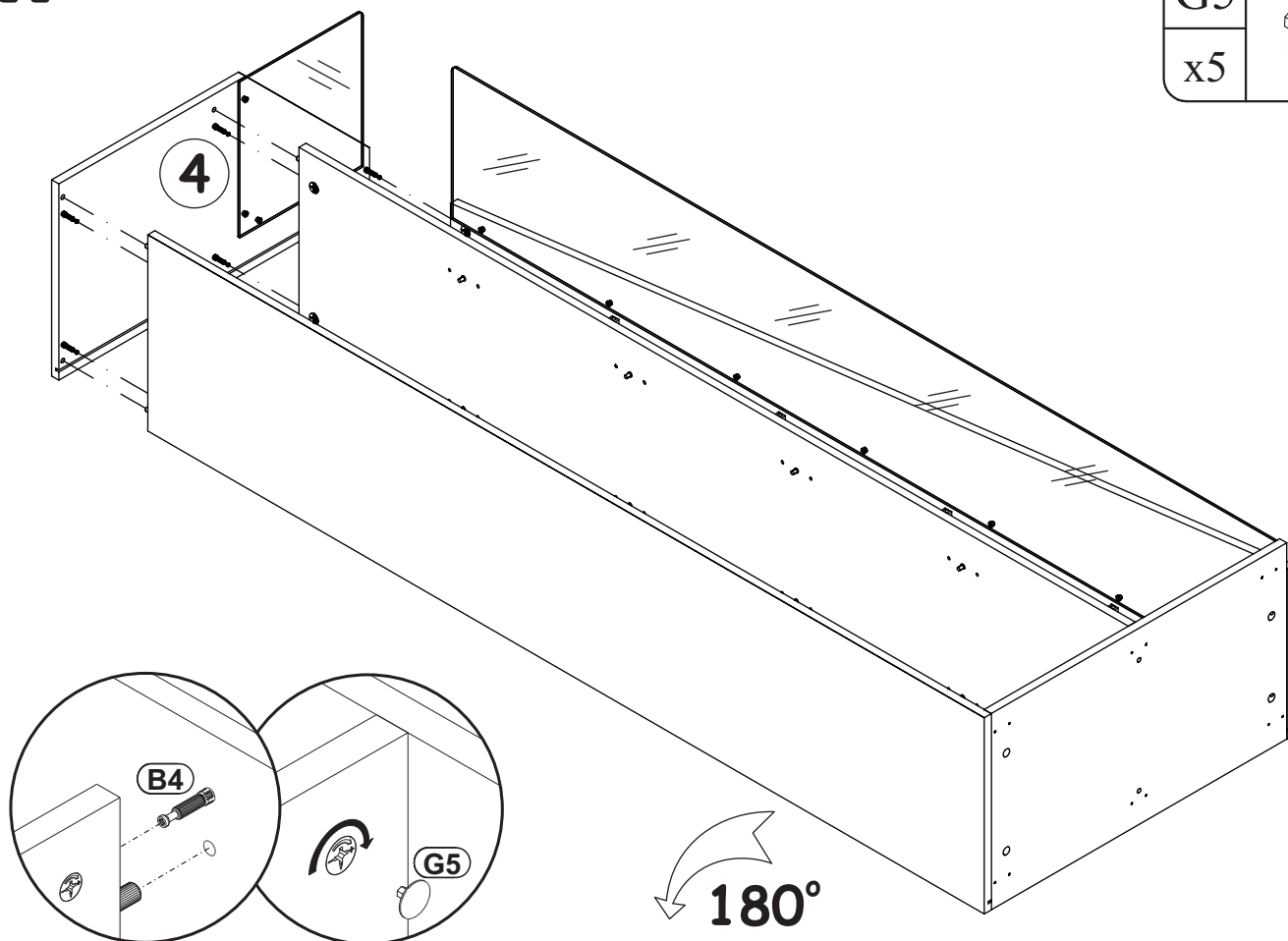
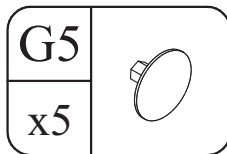

EDGE 29 -- EE WSW

12

S1		G16		UP13		ST17	
x18		x12		x12	UPØ3x16	x6	

UP11	
x12	UPØ4x20

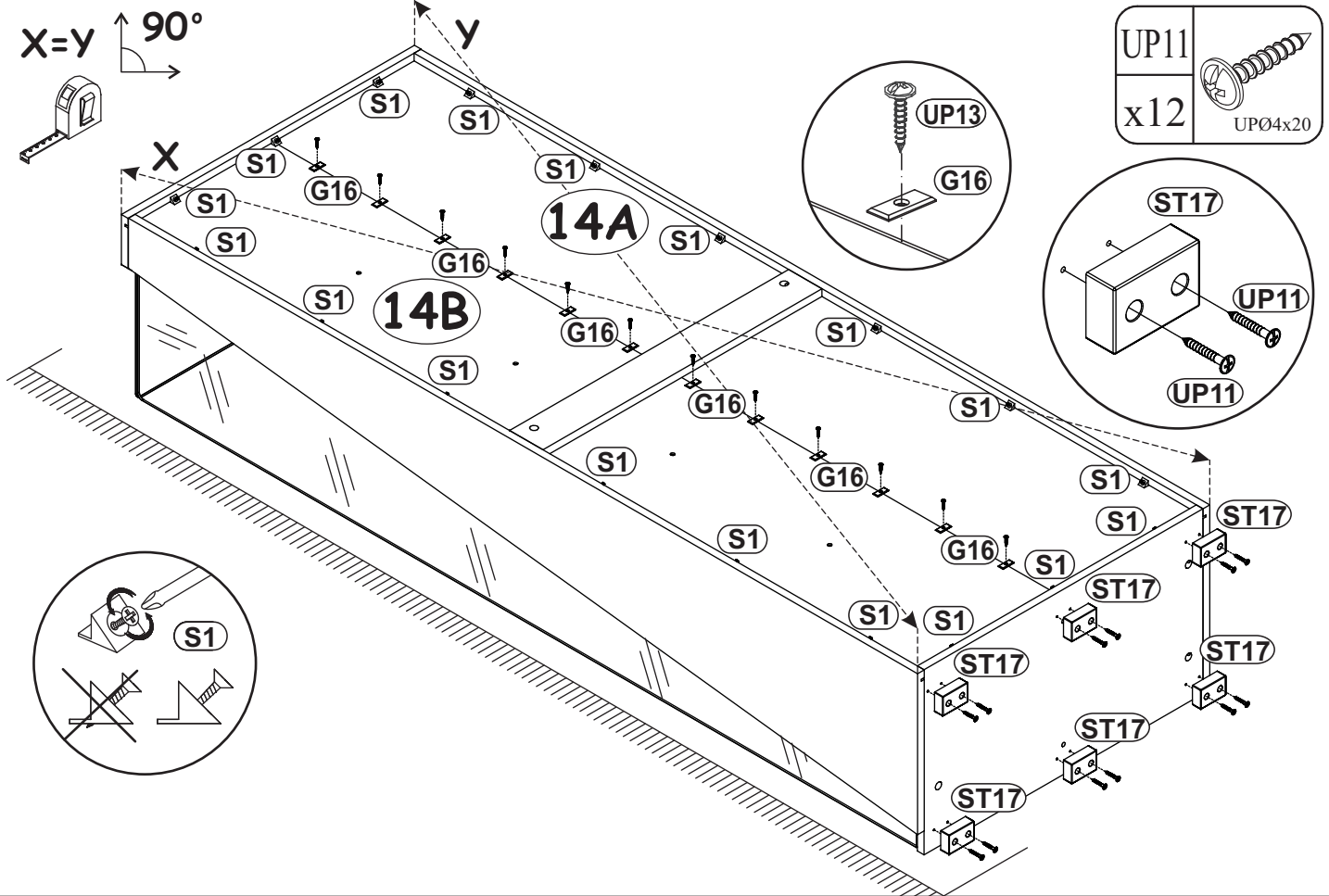

13

LED	
x1	x4

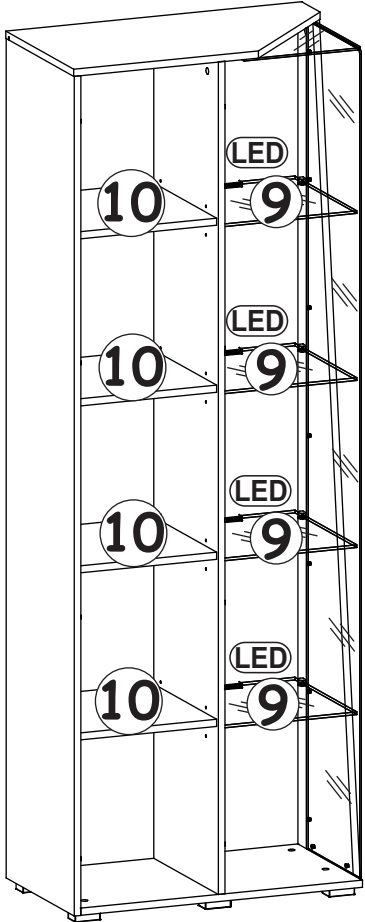
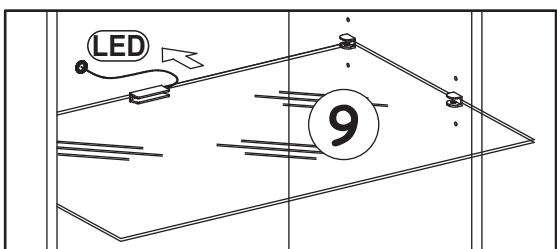
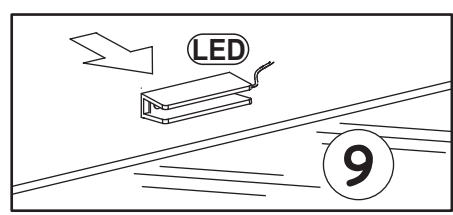

14

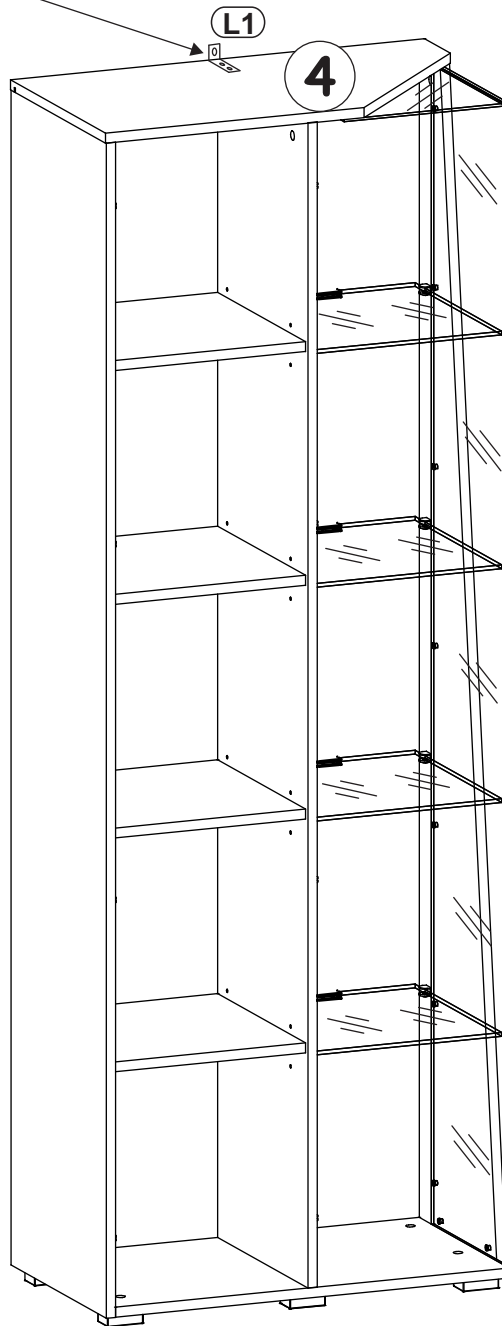
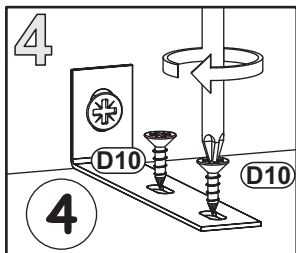
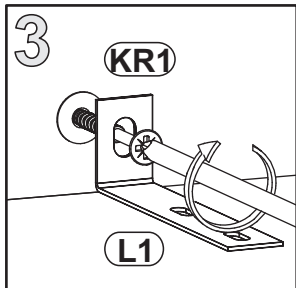
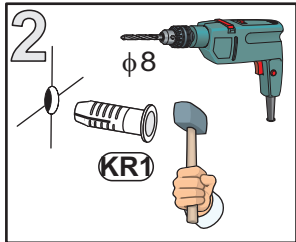
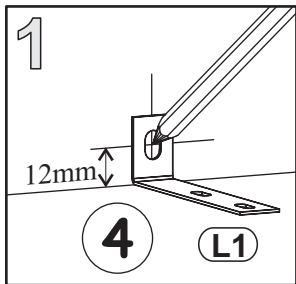
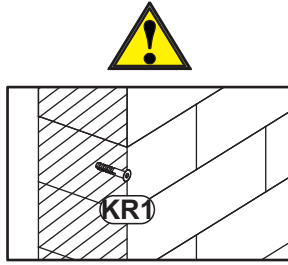
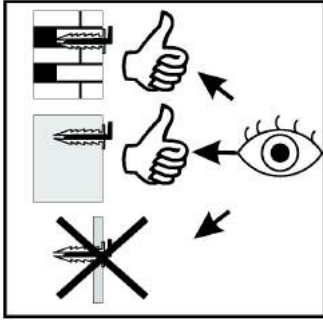
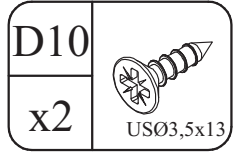
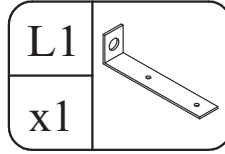
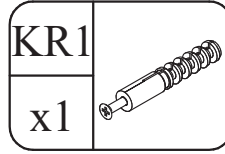

15

