



ANTRESOLA - L

➔ 204 ↑ 190 ↓ 120

x 78 	x 53 	x 6 	x 65 	x 82 	x 2 	x 6 	x 8
x 6 	x 3 	x 18 	x 4 				
x 15 	x 5 	x 2 	x 4 				
x 12 (6,2x30) 	x 60 (3,5x16) 	x 14 (3,5x30) 	x 2 				
x 40 	x 1 						
x 2 kpl. (300 mm) 	x 1 kpl. (350 mm) 	x 1 (816mm) 					

ZALECANY ROZMIAR MATERACA 80 X 200 (MAKSYMALNA GRUBOŚĆ MATERACA - 10 CM)

① - FAZY MONTAŻU

Ⓐ - OZNACZENIE ELEMENTÓW

Ⓐ - OZNACZENIE AKCESORIÓW

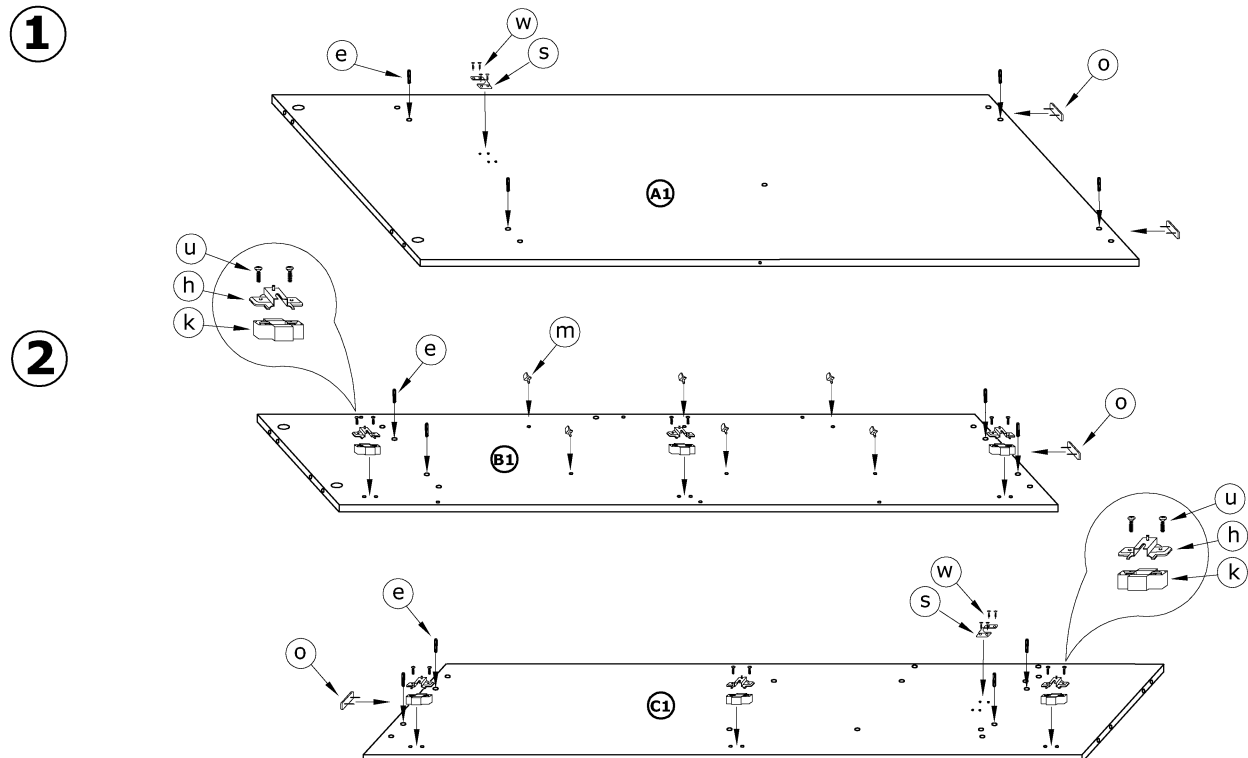

3

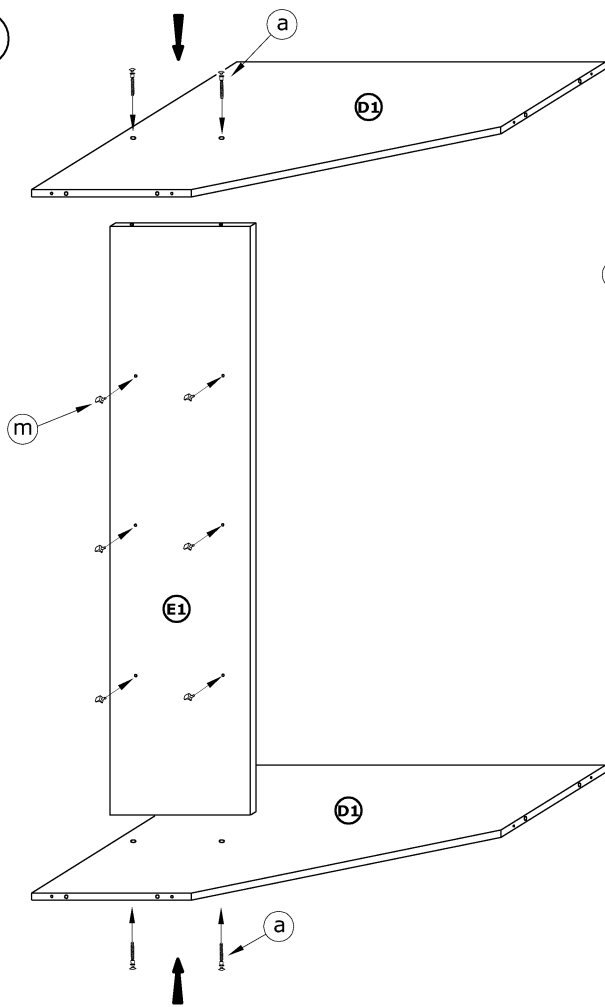

5

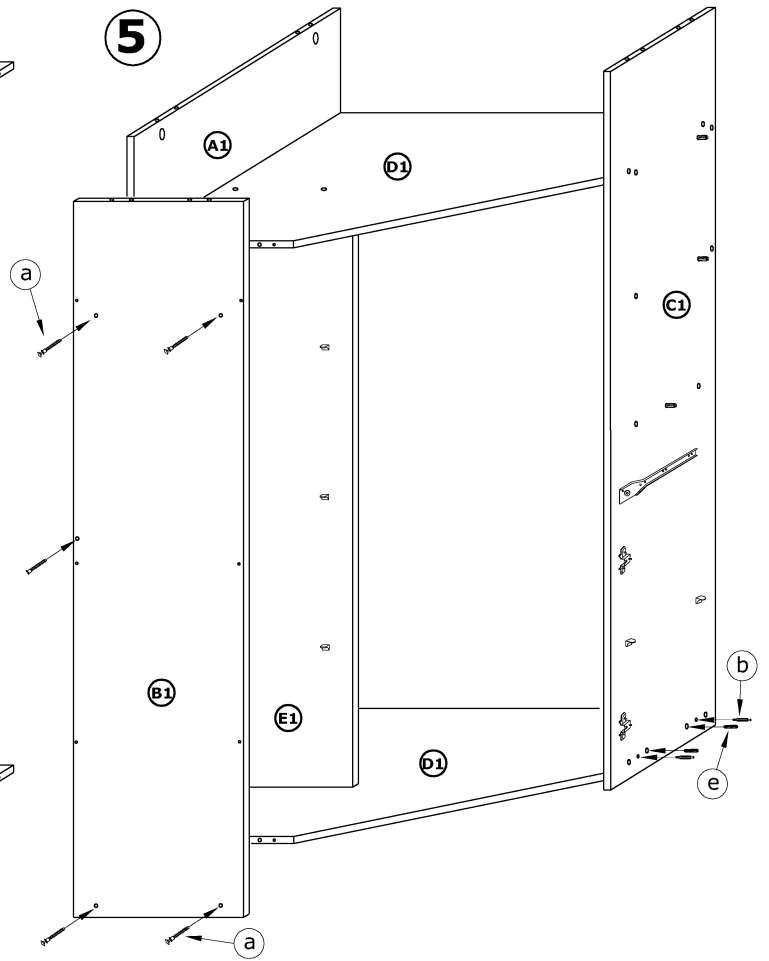

4

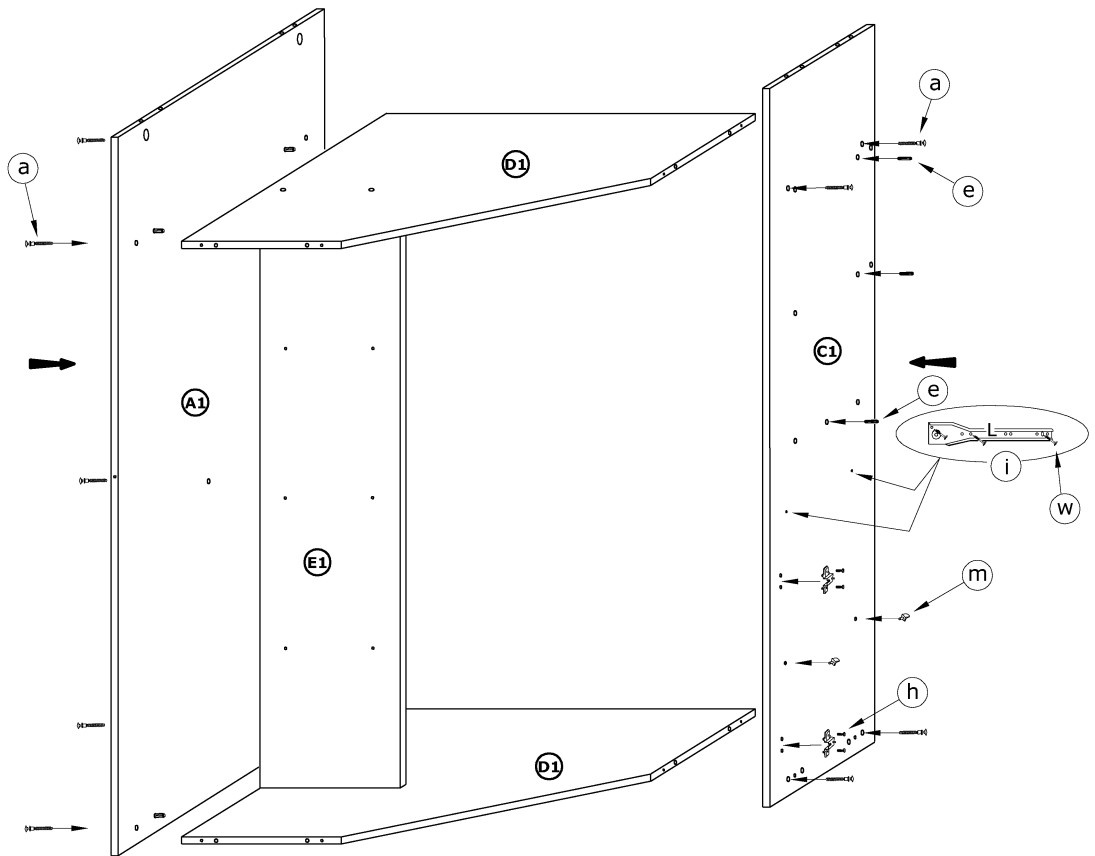

6

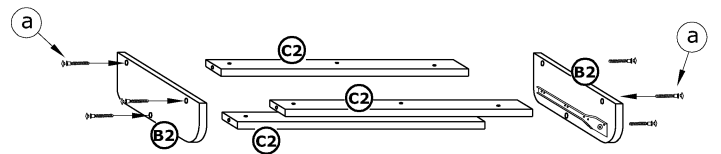
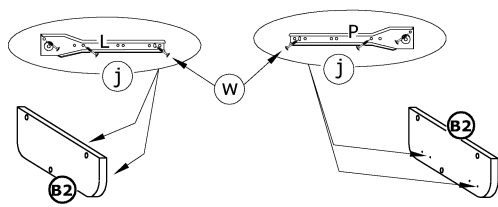

7

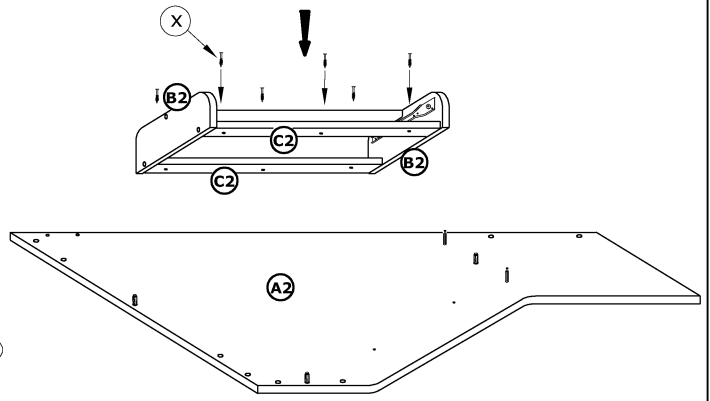
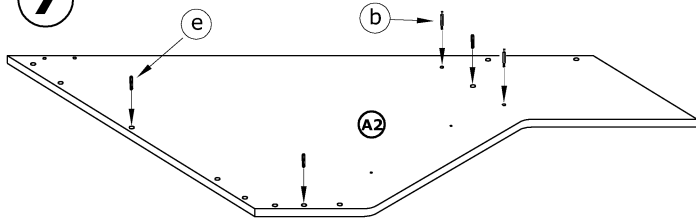

8

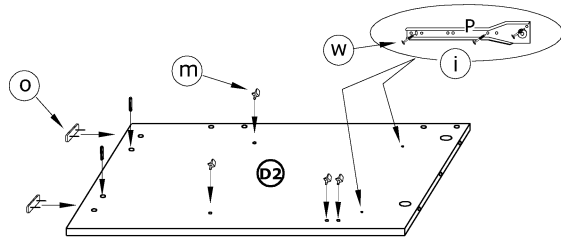

9

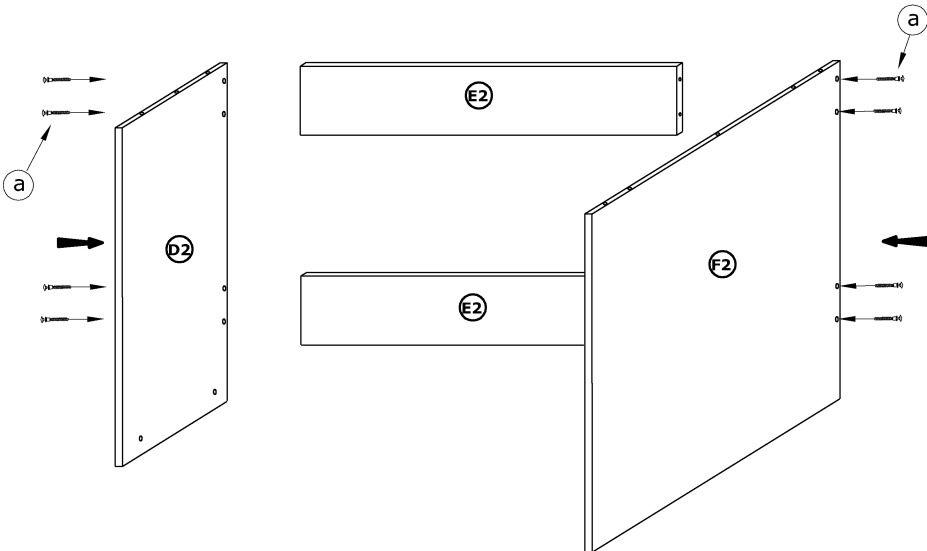

10

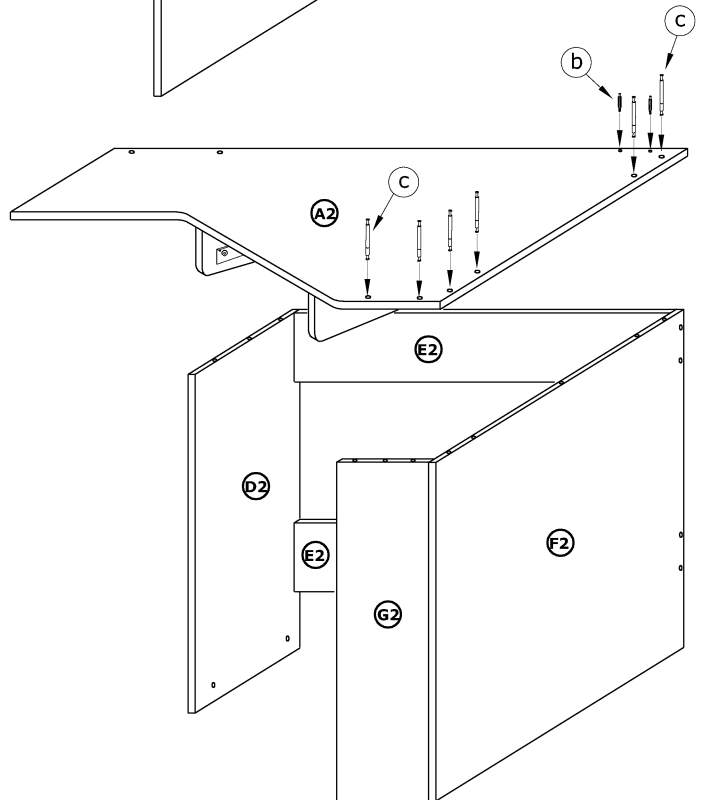
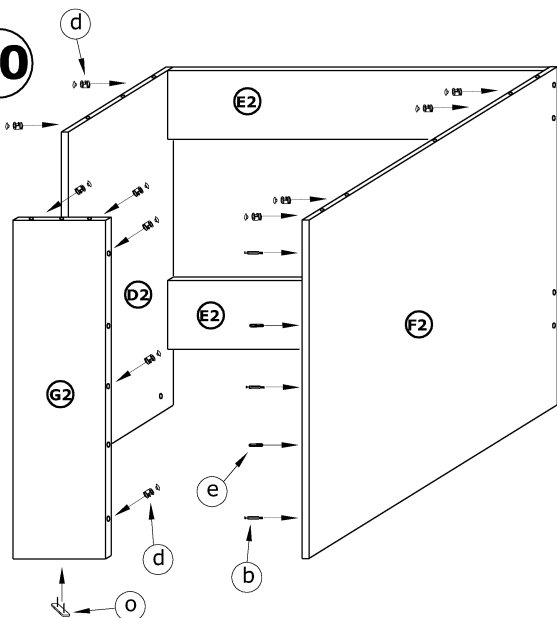

11

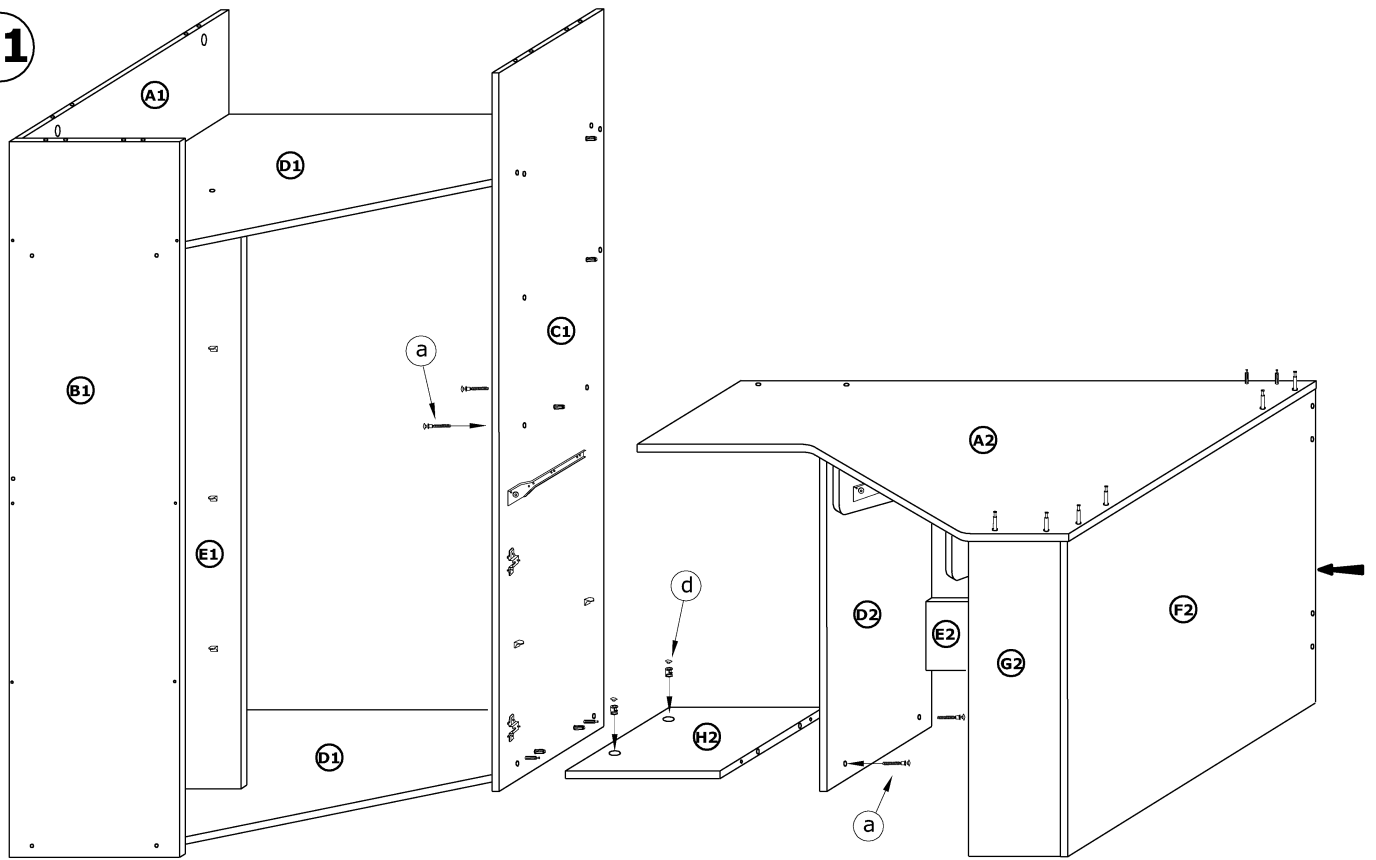

12

x 2

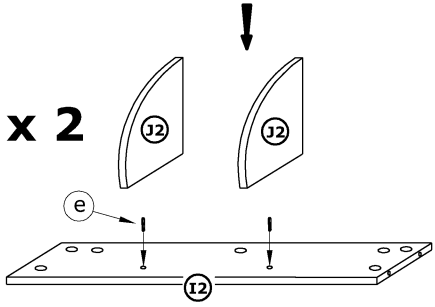

x 2

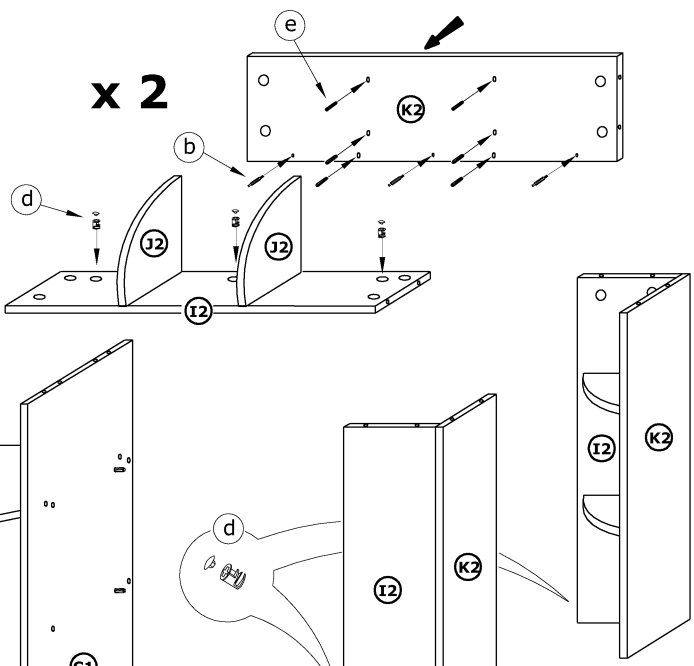

13

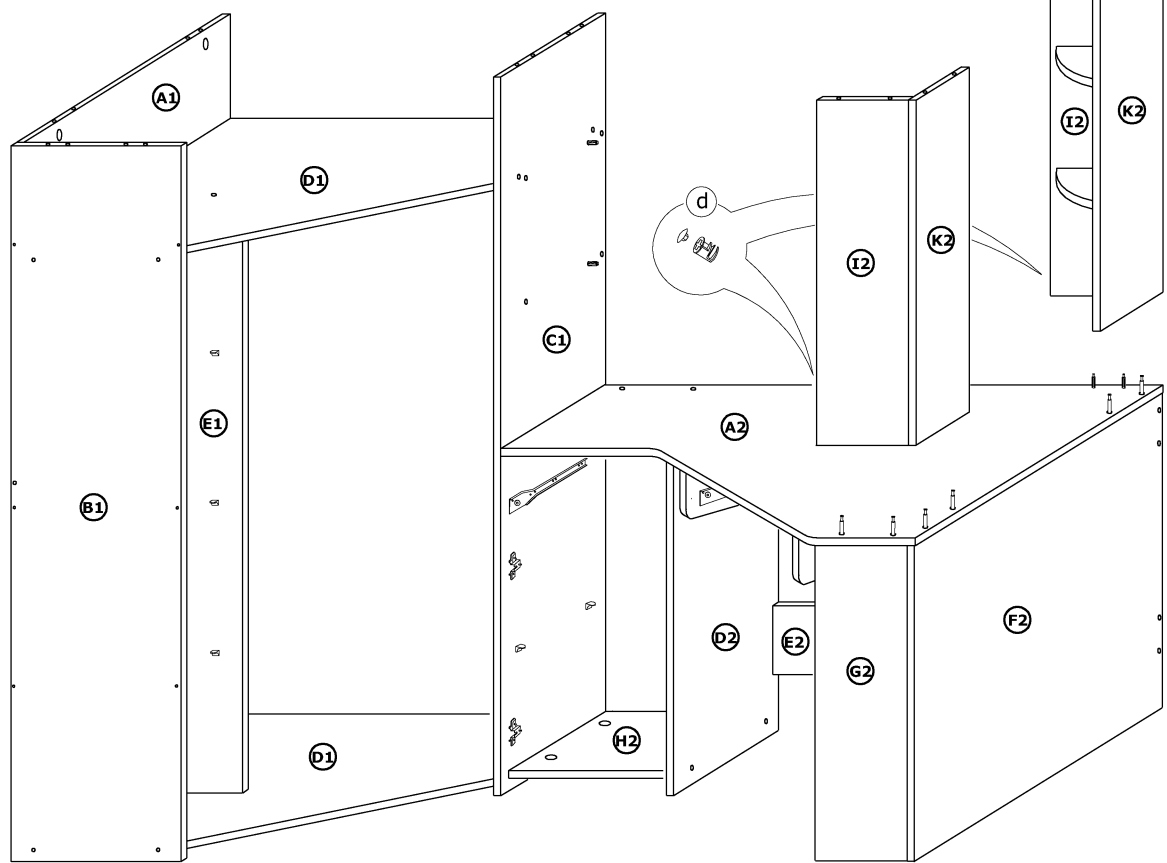

14

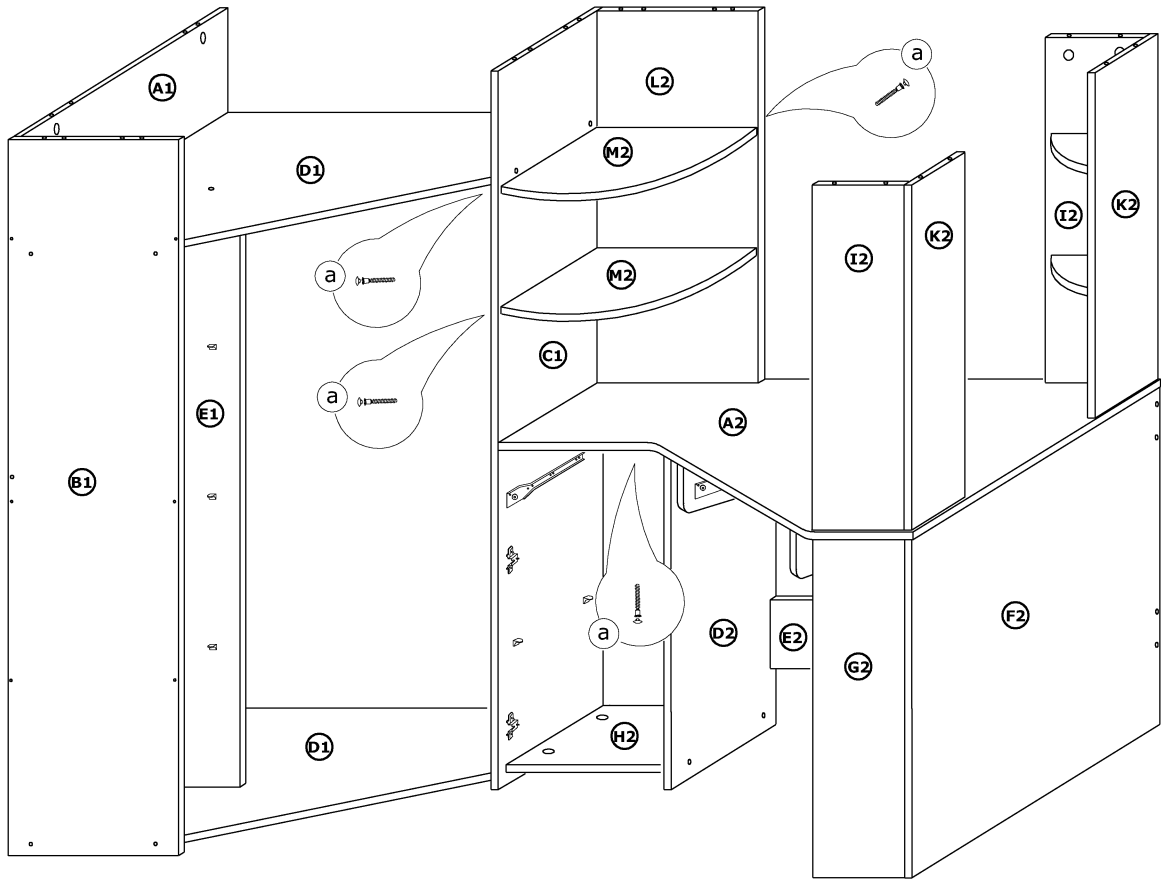

15

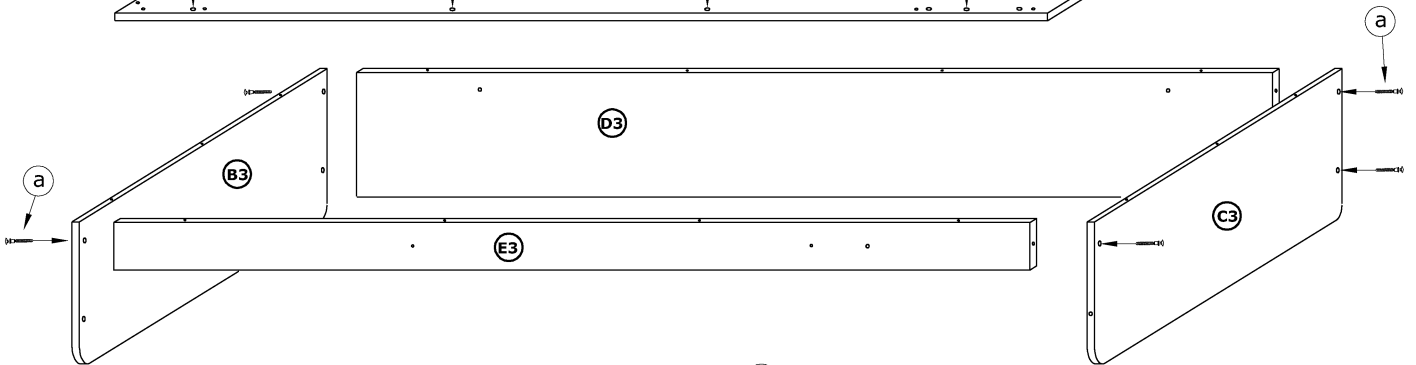
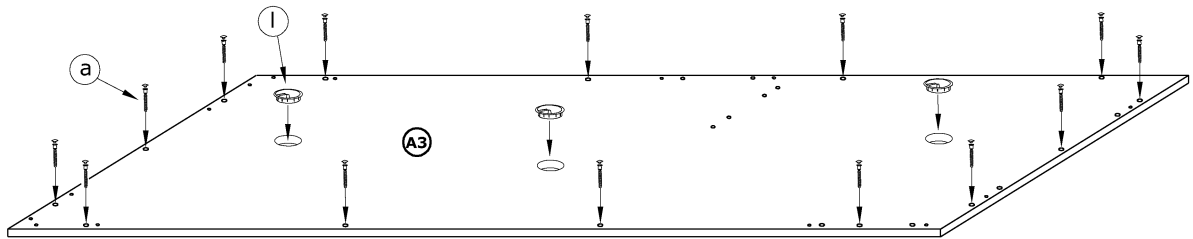

16

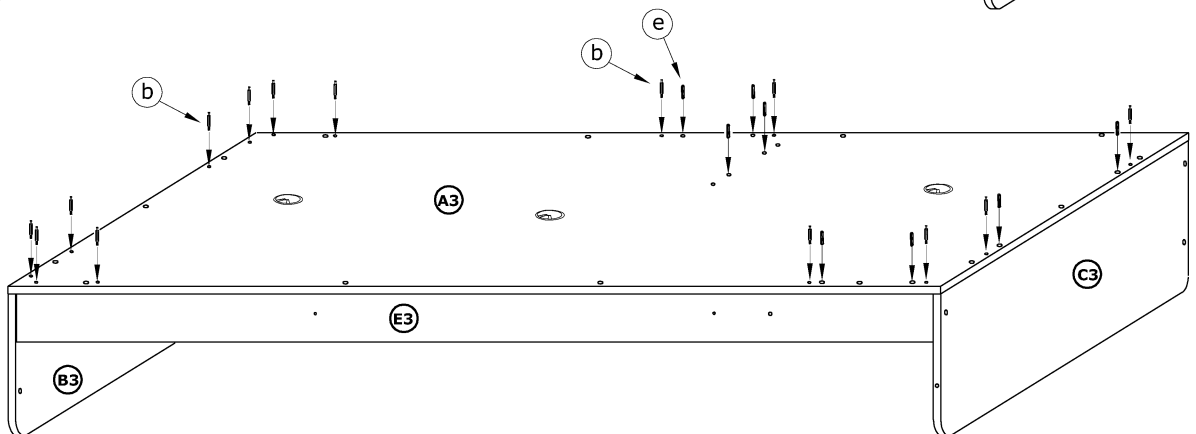

17

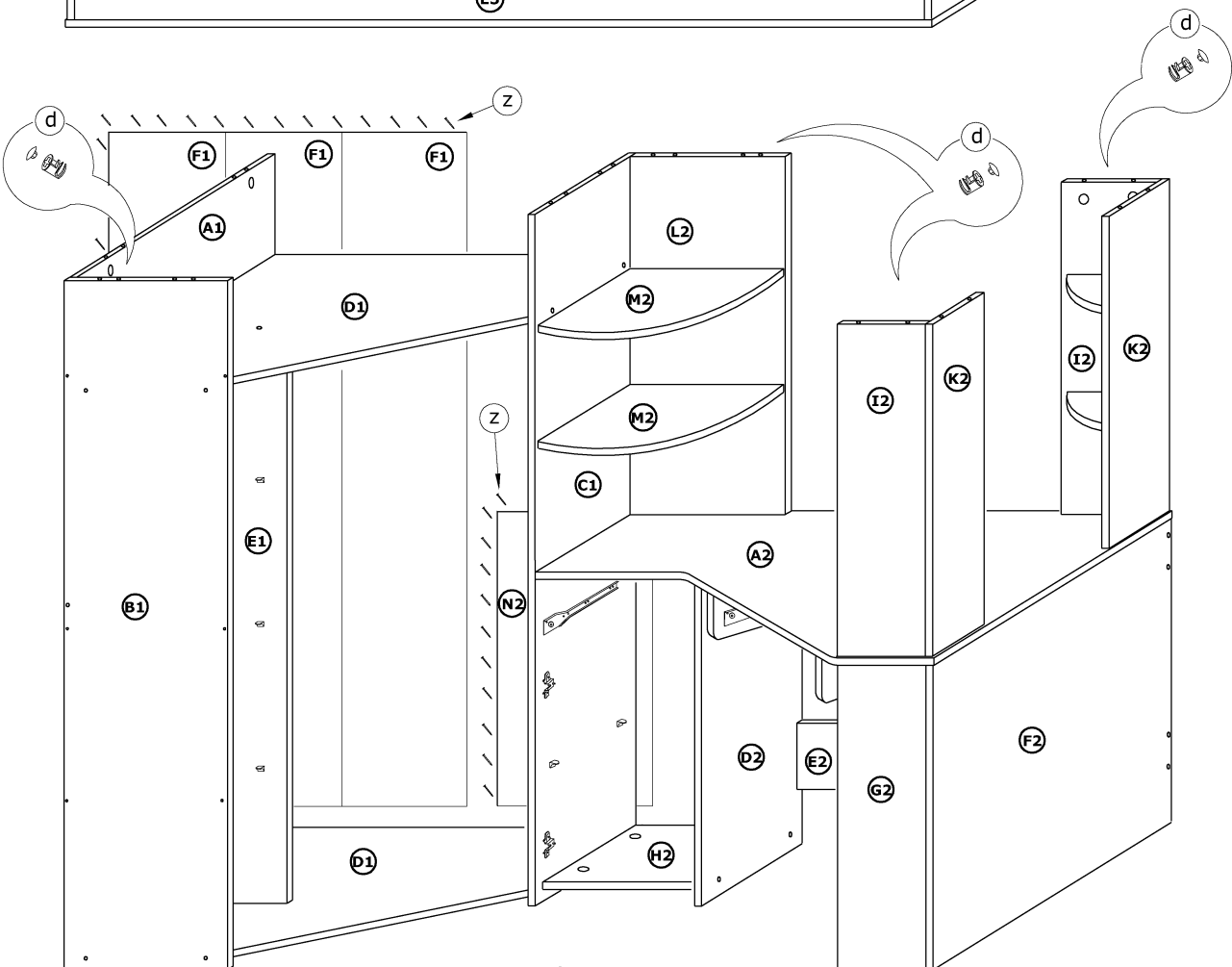
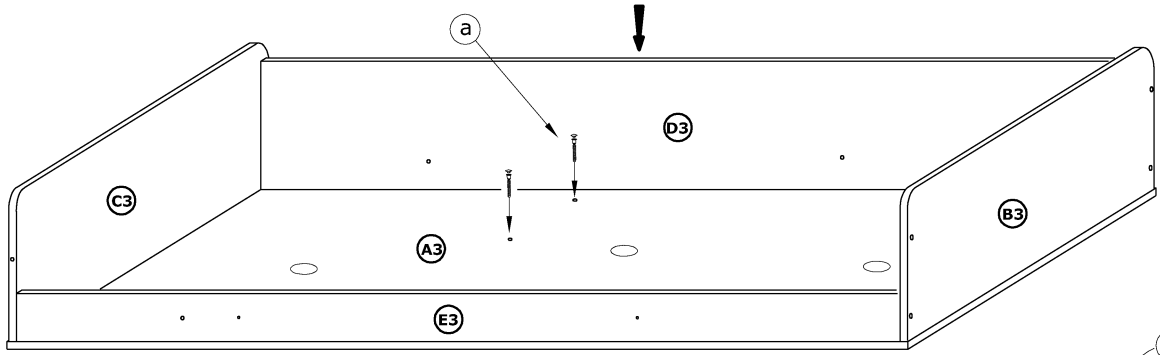

18

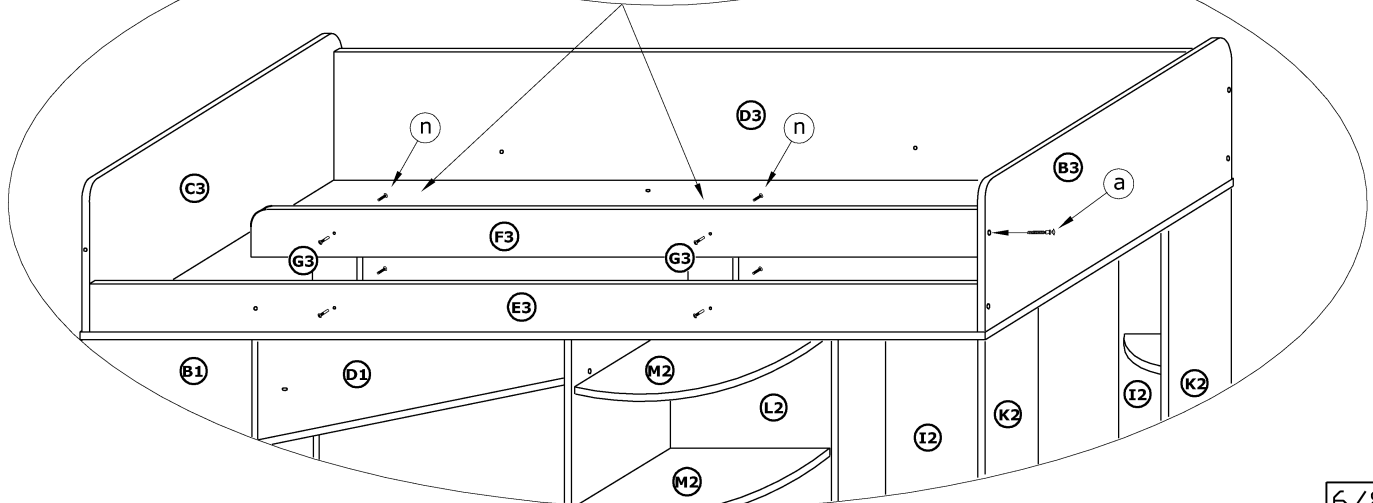
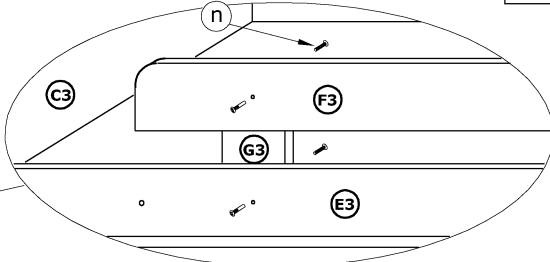

19

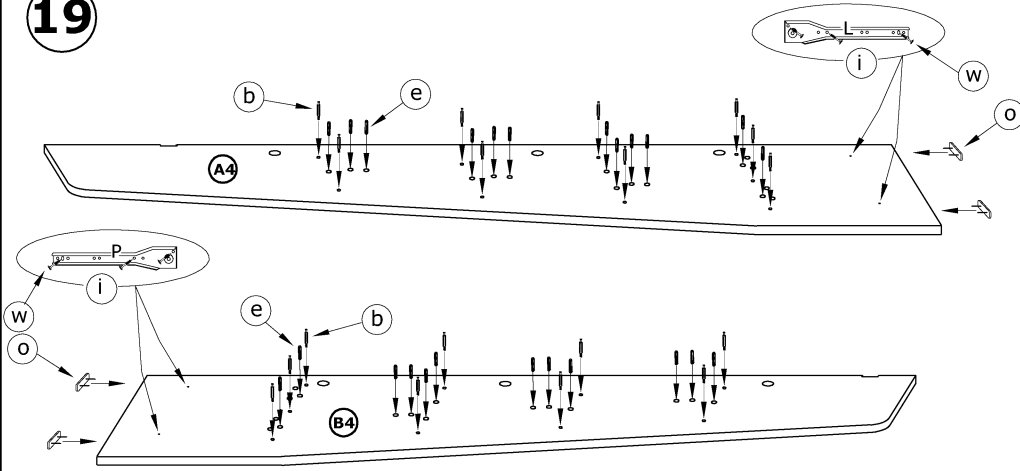

22

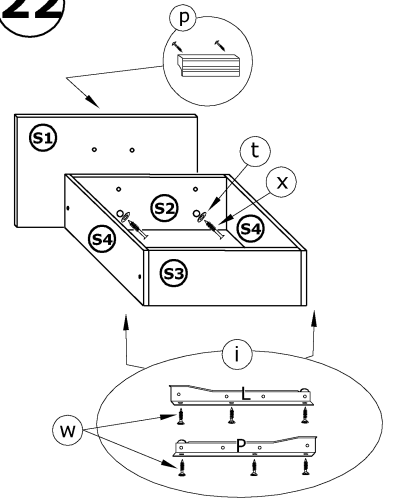

20

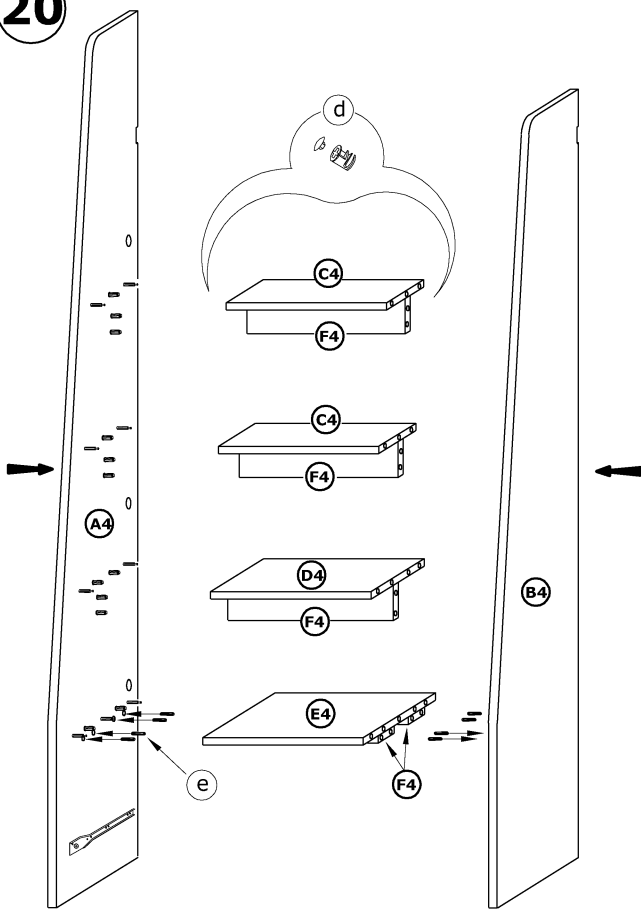

23

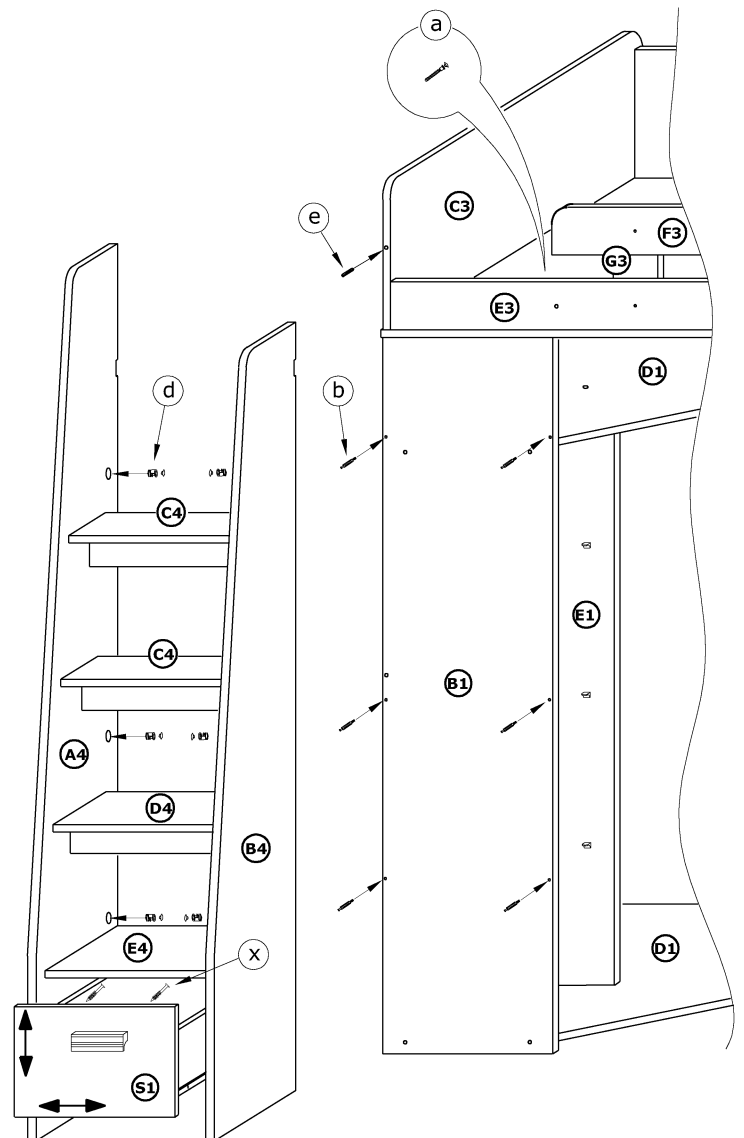

21

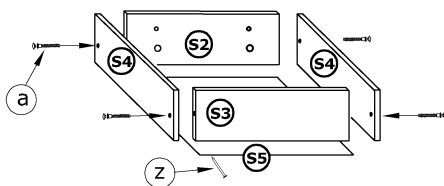

24

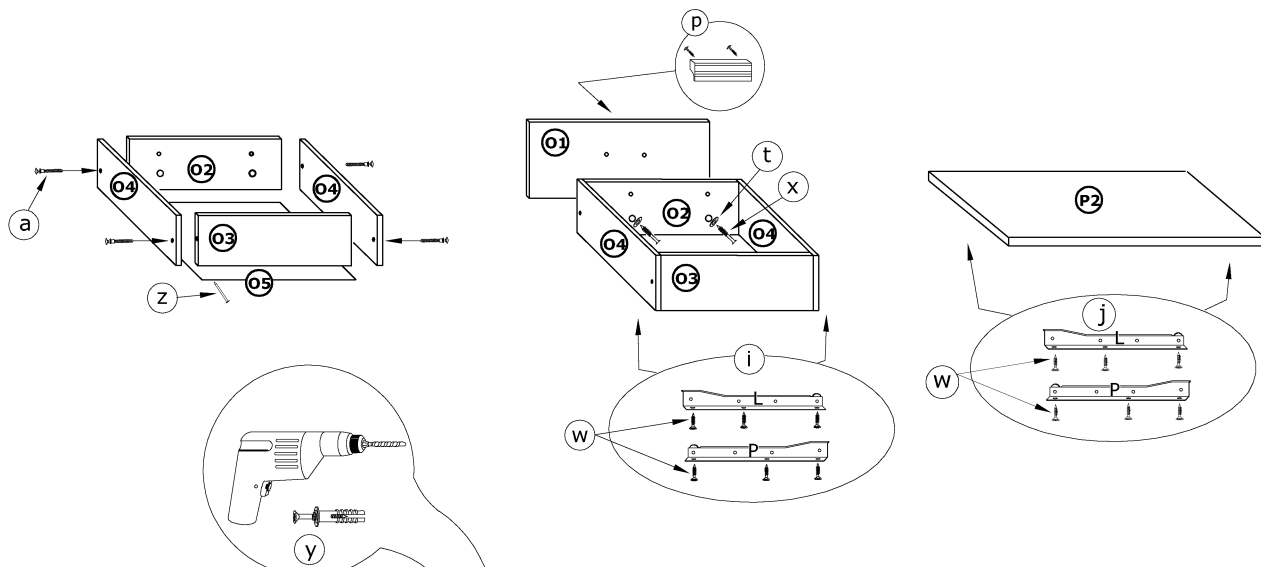



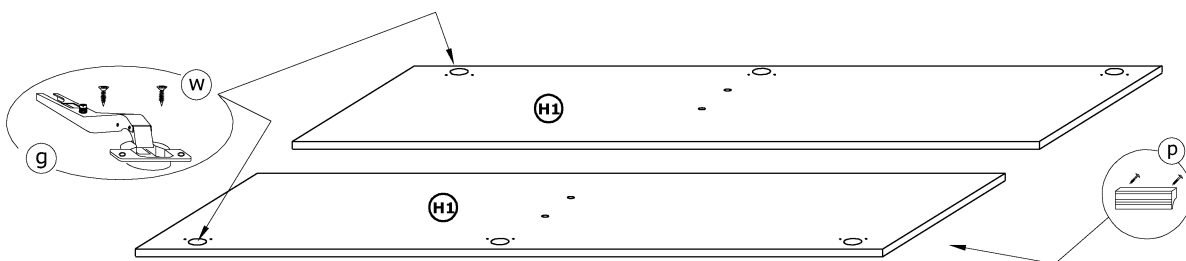
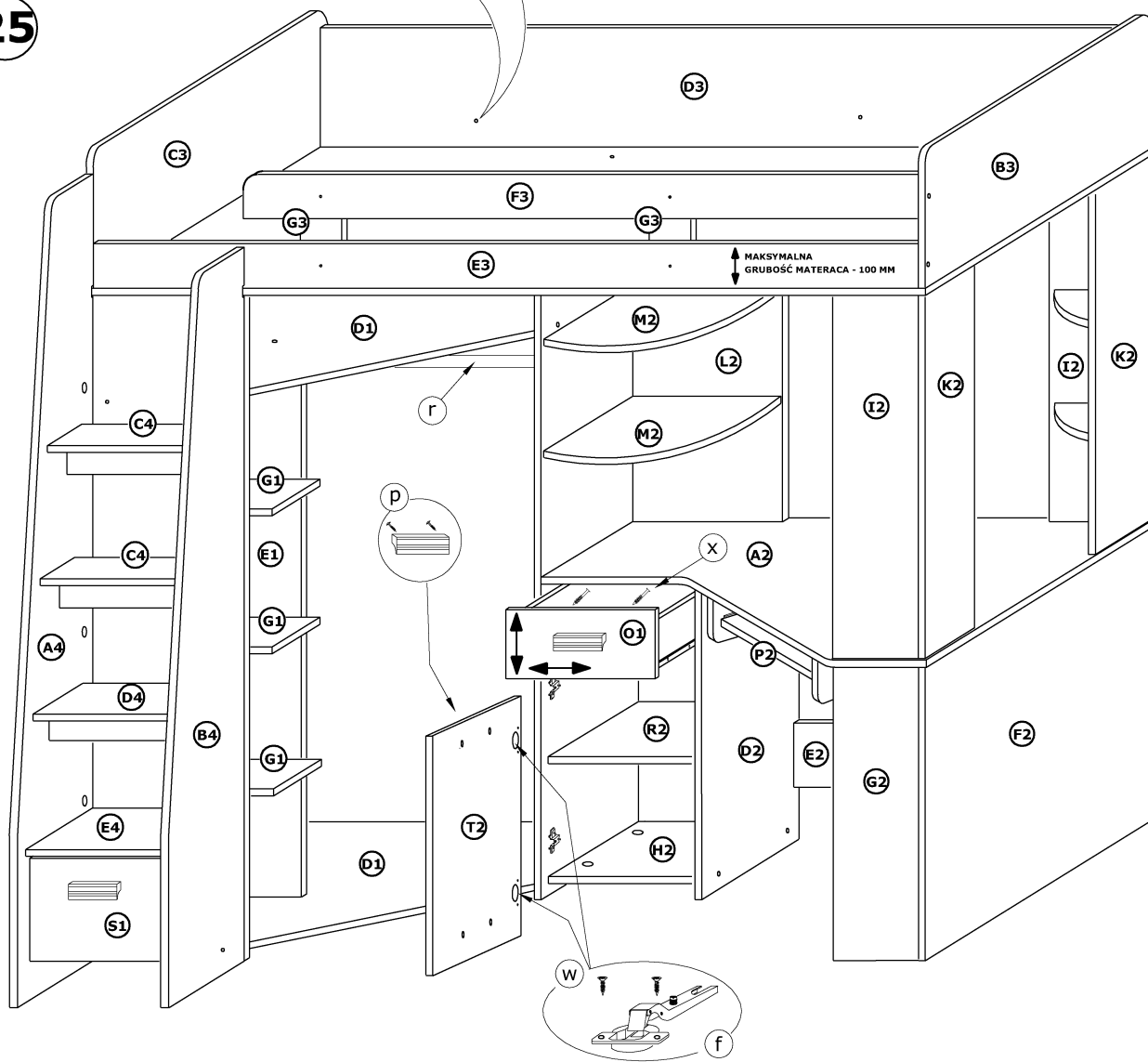









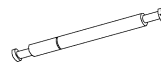

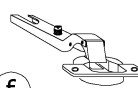
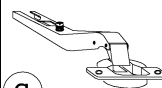
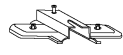

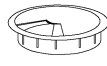
25

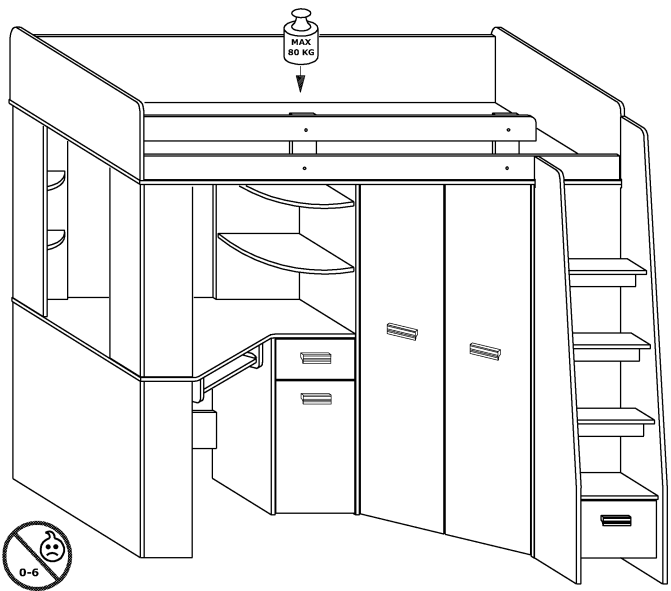



ANTRESOLA - P

➤ 204 ↑ 190 ↘ 120

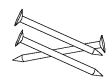
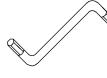
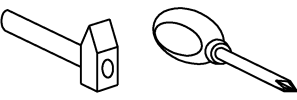
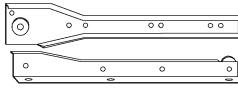
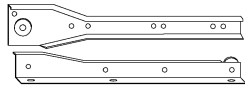
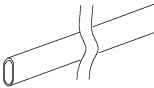
x 78  a	x 53  b	x 6  c	x 65  d	x 82  e	x 2  f	x 6  g	x 8  h
x 6  k	x 3  l	x 18  m	x 4  n				
x 15  o	x 5  p	x 2  s	x 4  t				
x 12 (6,2x30)  u	x 60 (3,5x16)  w	x 14 (3,5x30)  x	x 2  y				
x 40  z	x 1  q						
x 2 kpl. (300 mm)  i	x 1 kpl. (350 mm)  j	x 1 (816mm)  r					

ZALECANY ROZMIAR MATERACA 80 X 200 (MAKSYMALNA GRUBOŚĆ MATERACA - 10 CM)

1 - FAZY MONTAŻU

A - OZNACZENIE ELEMENTÓW

a - OZNACZENIE AKCESORIÓW

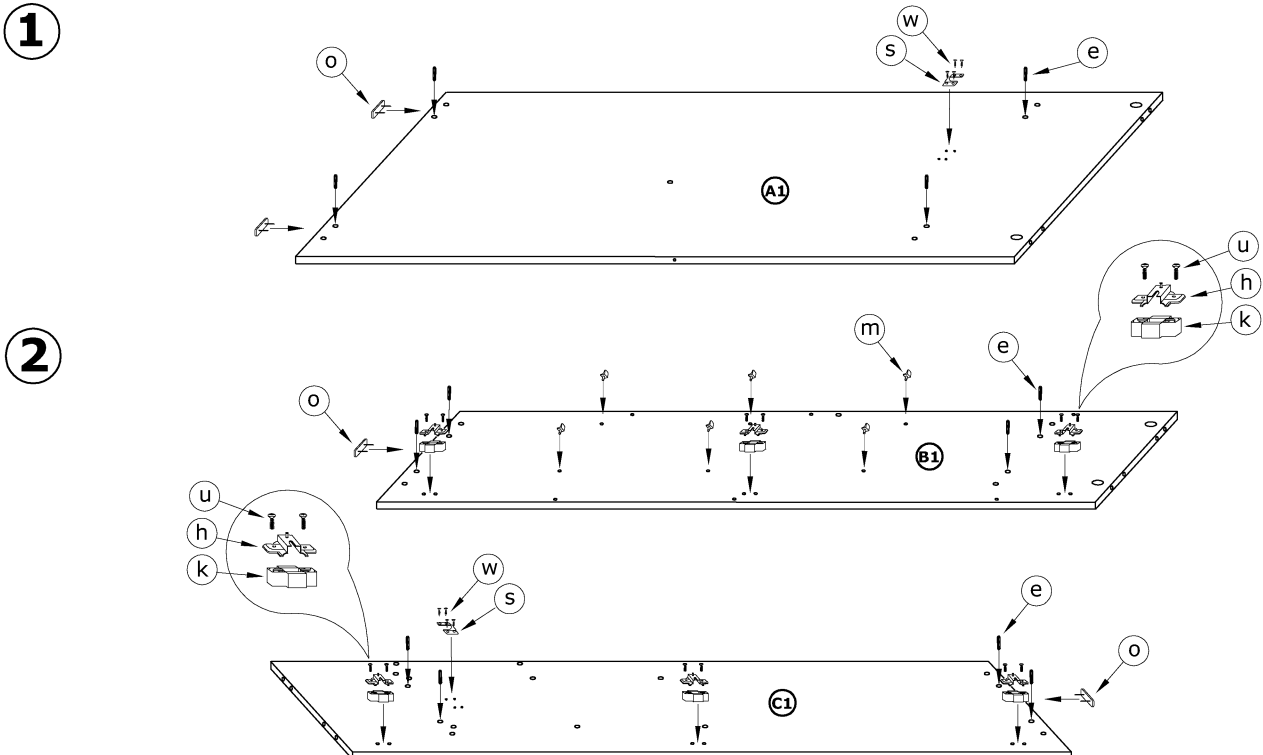

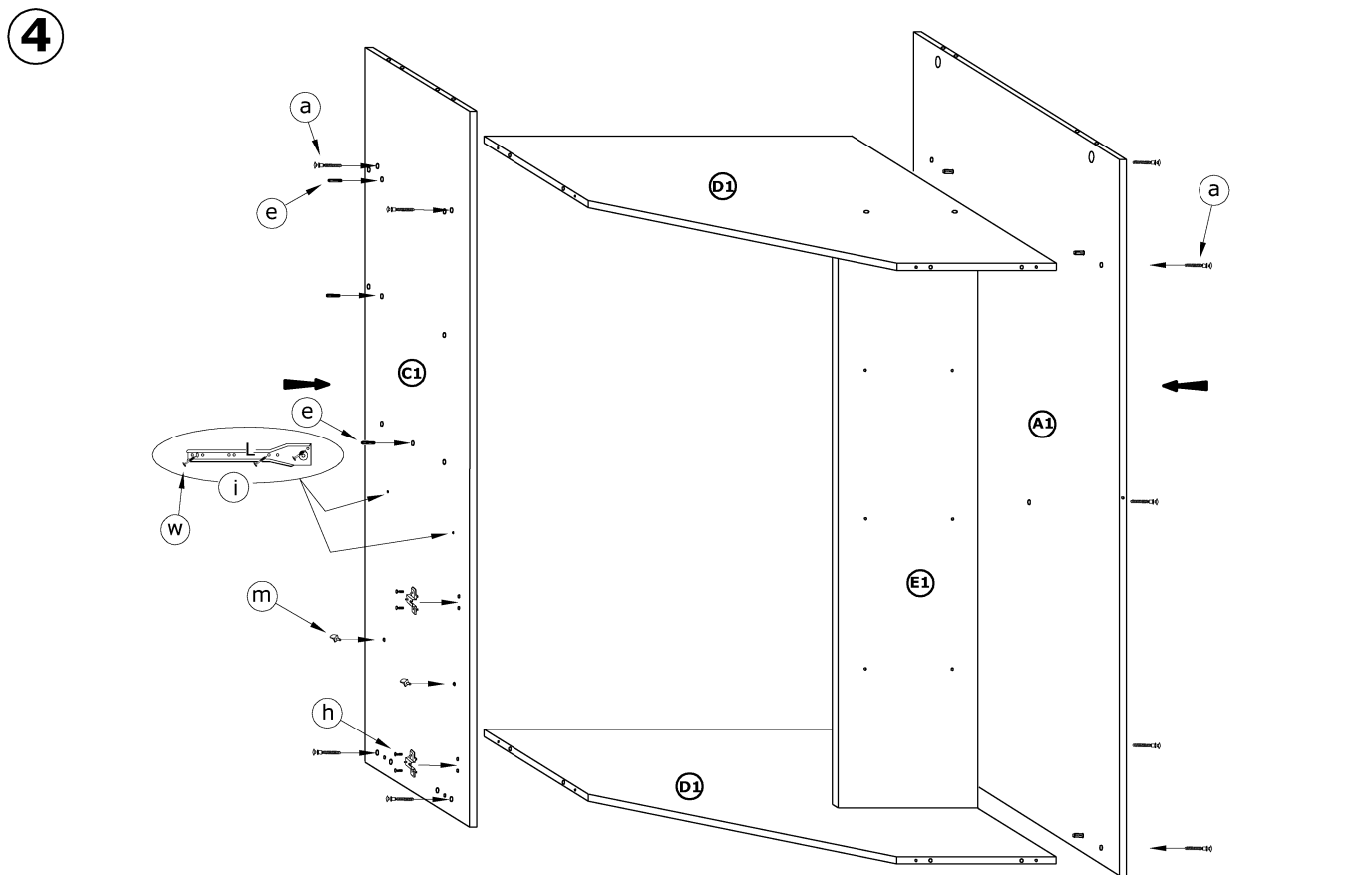
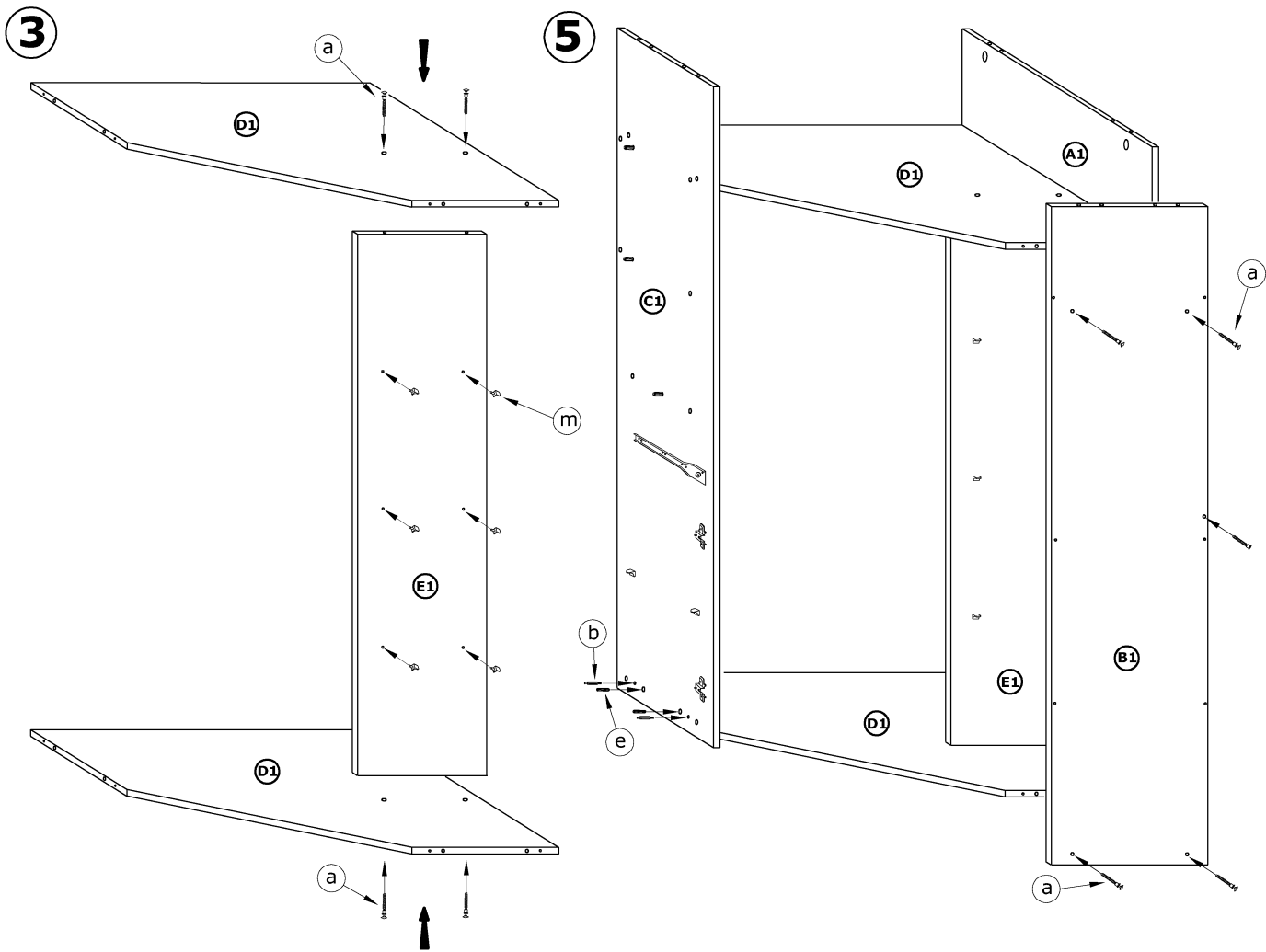

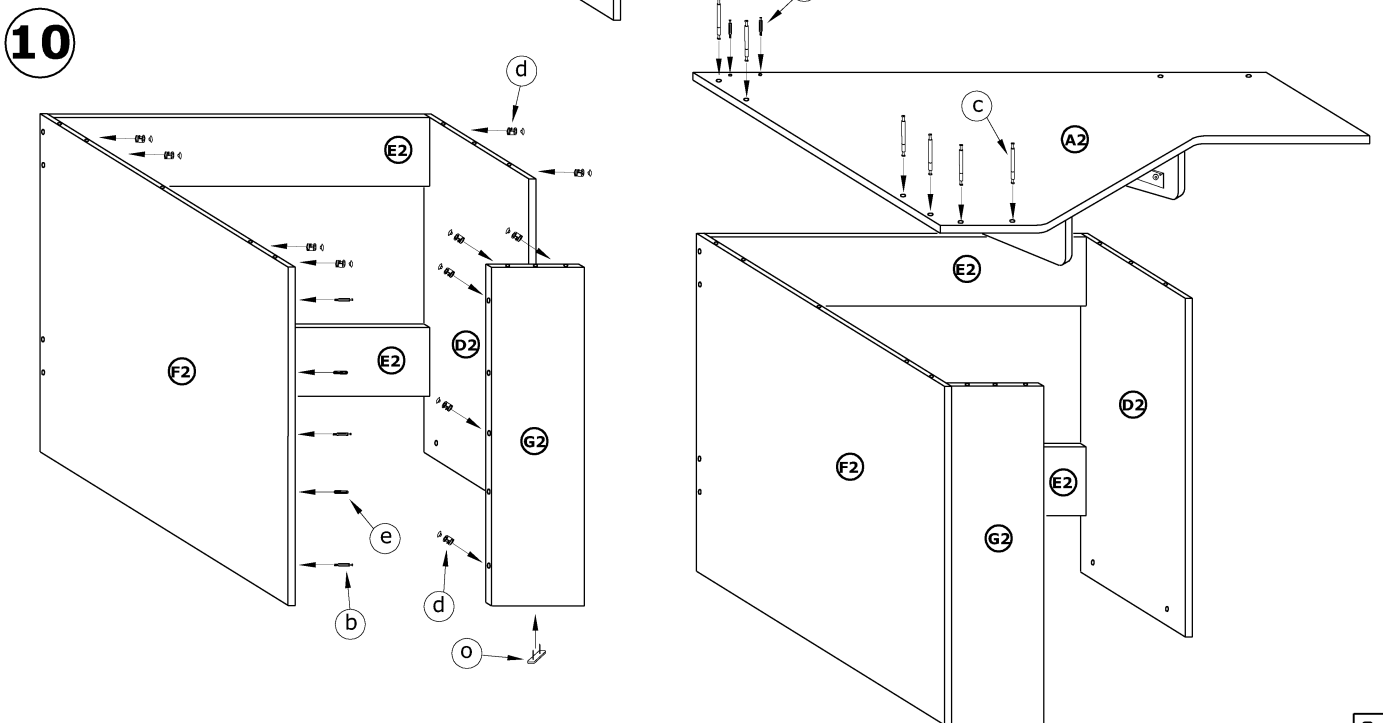
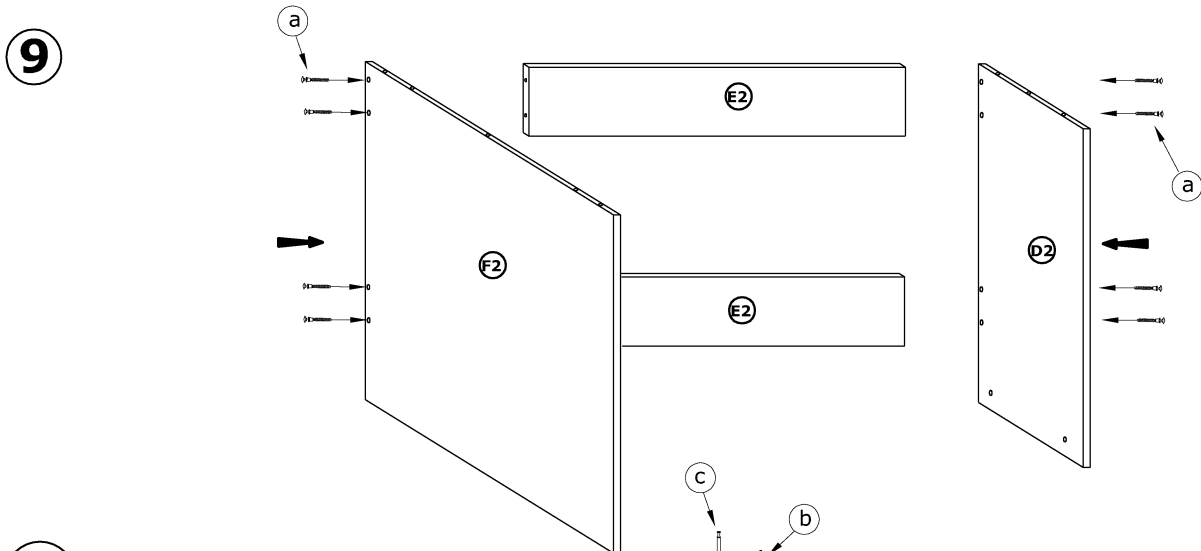
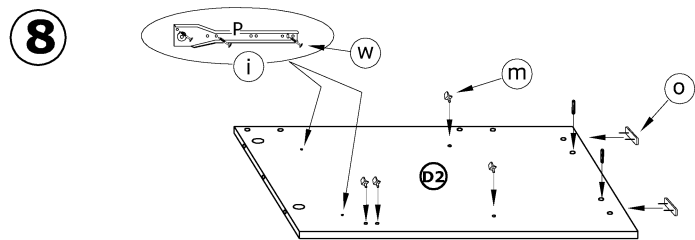
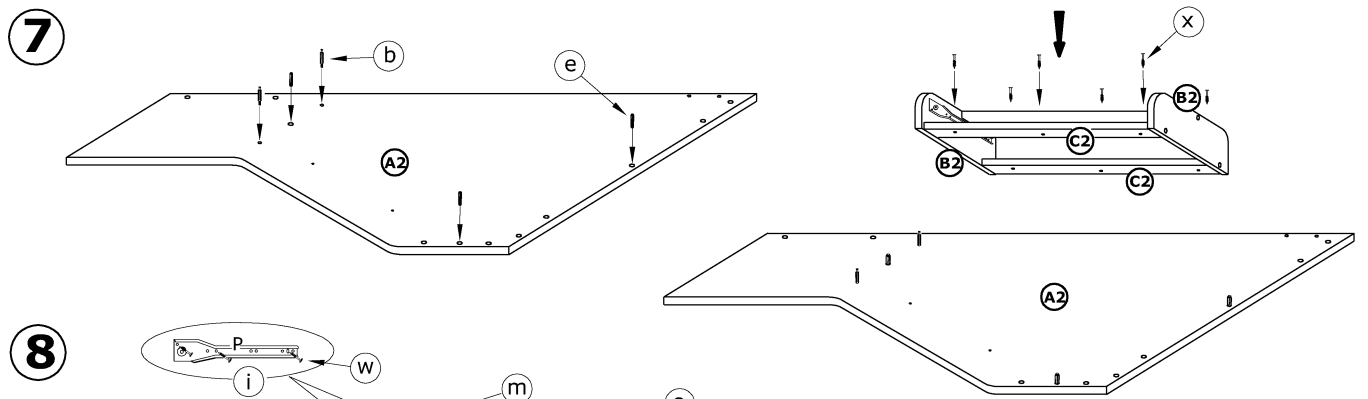
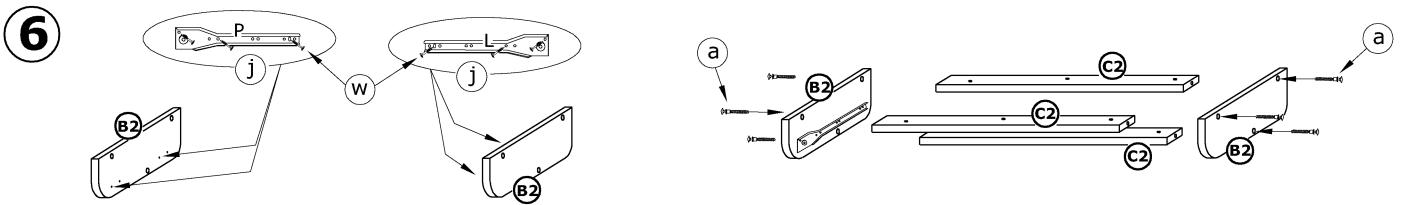

11

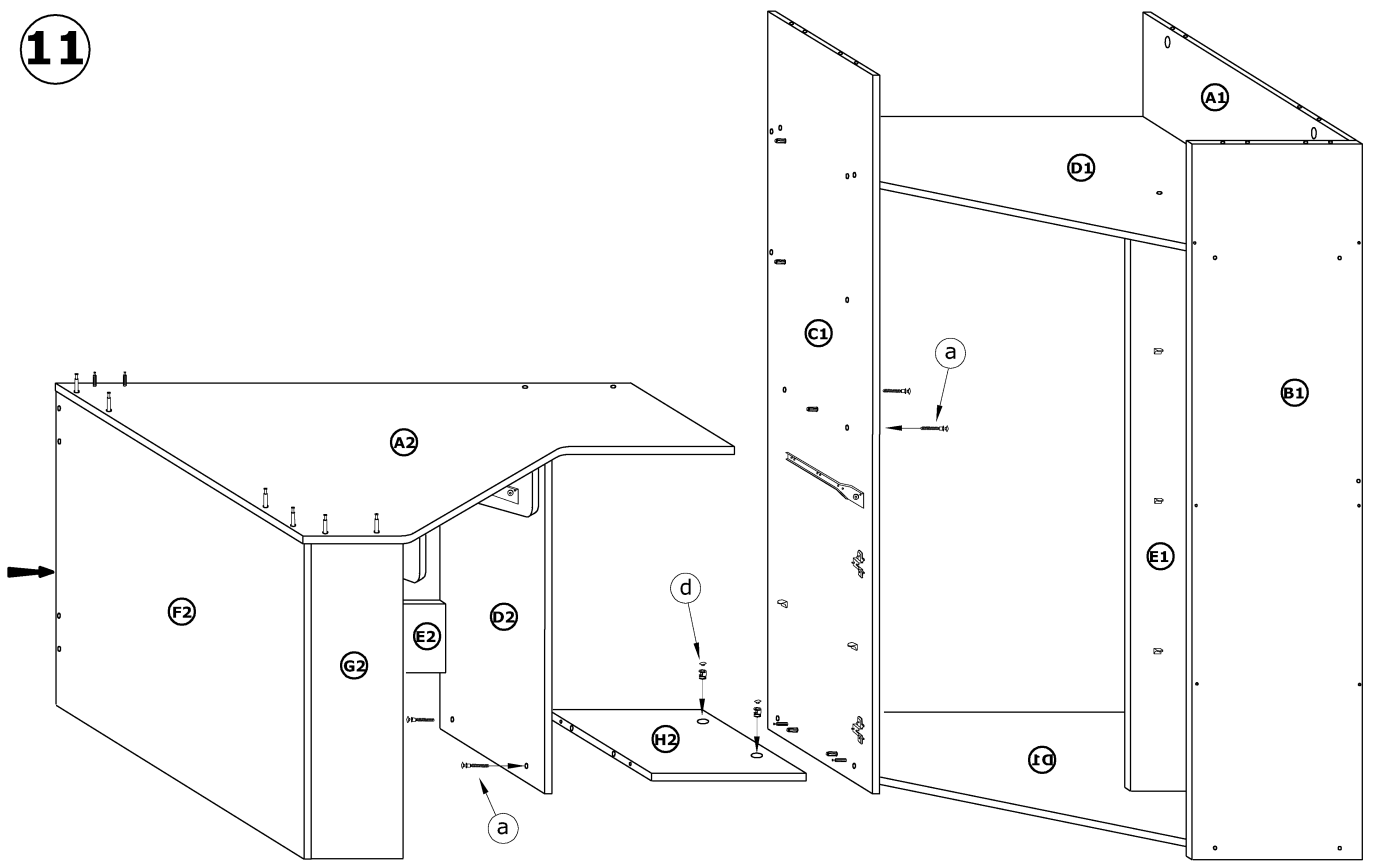

12 x 2

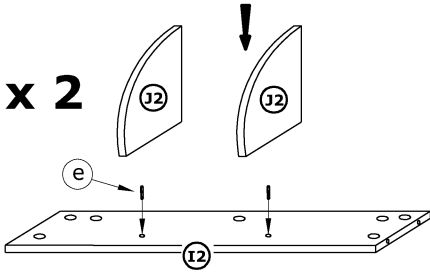

x 2

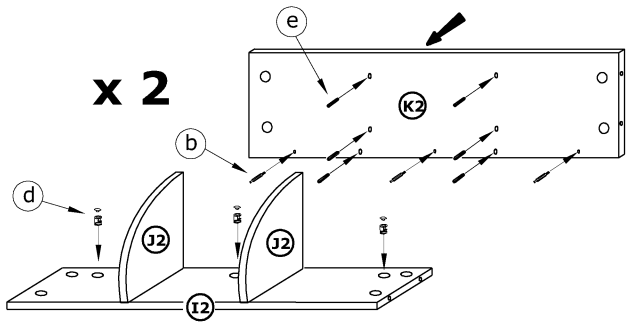

13

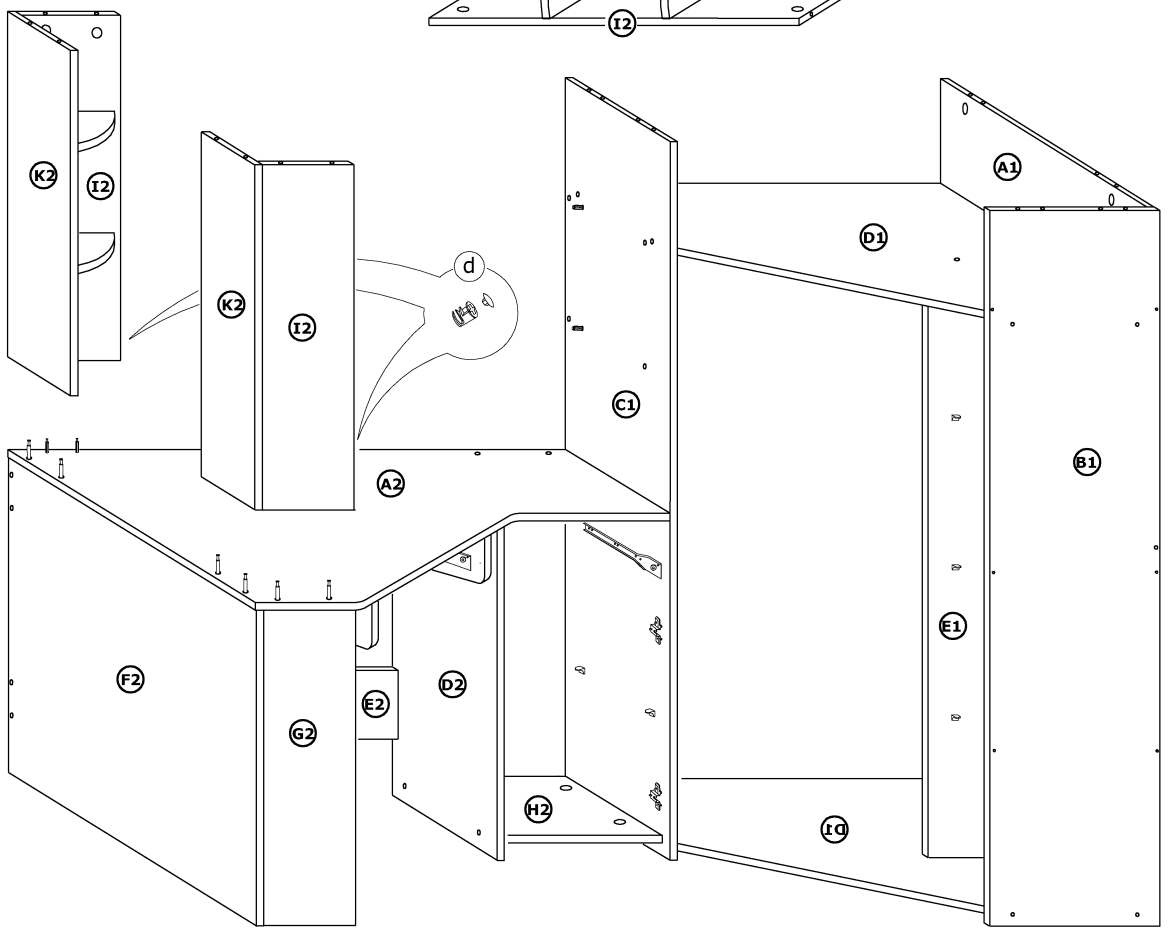

14

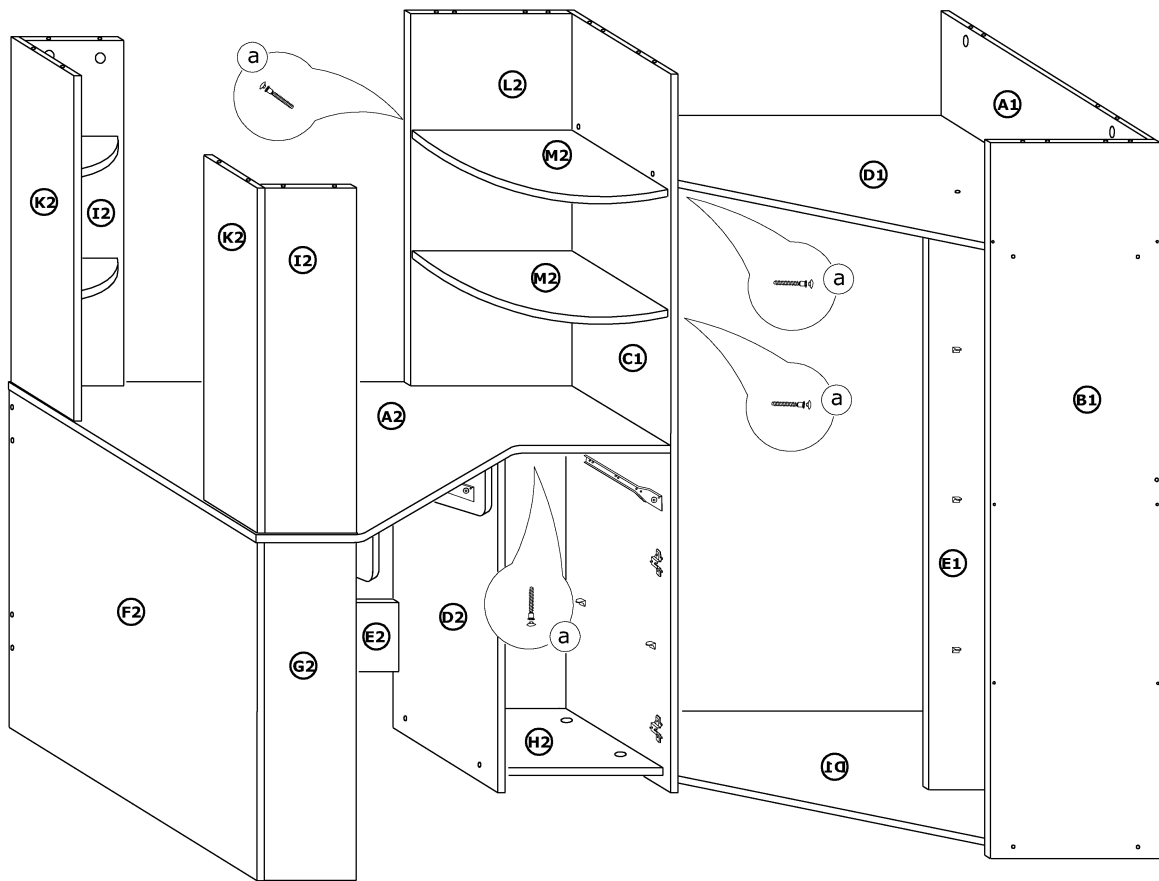

15

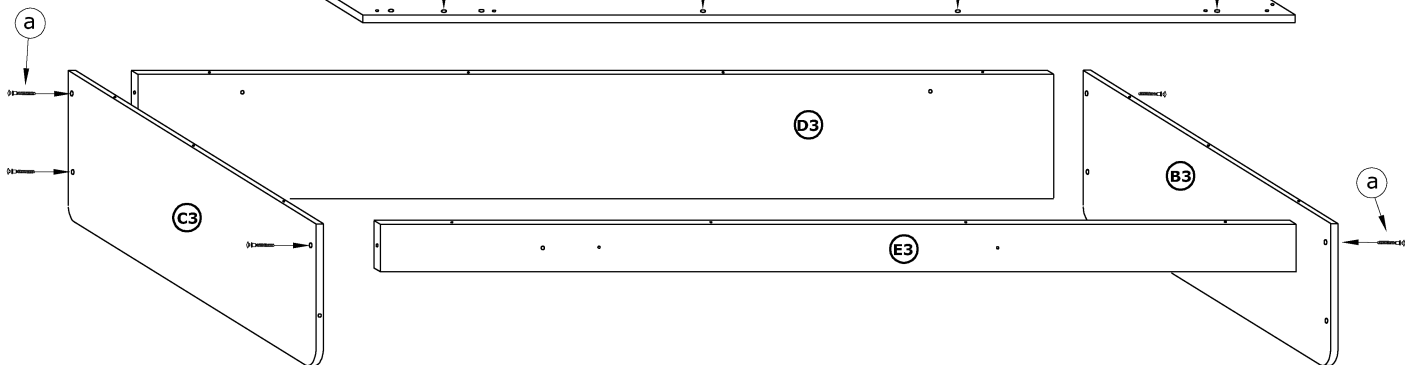
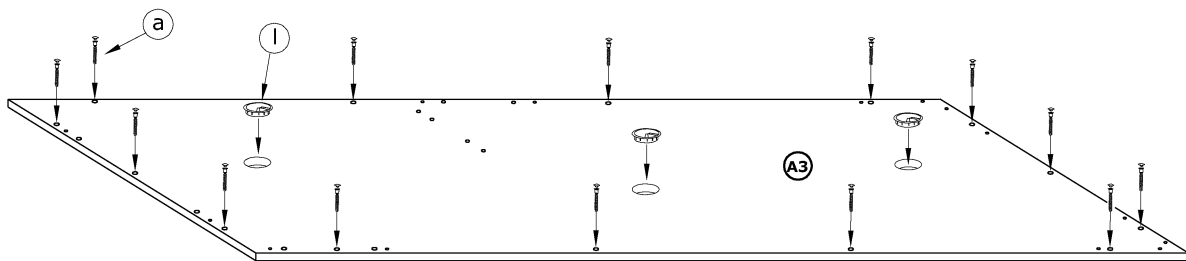

16

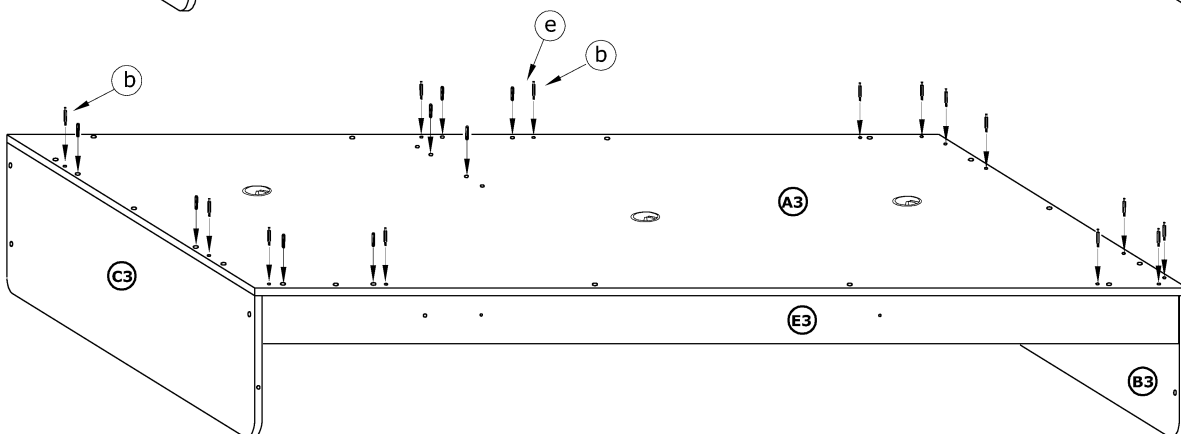

17

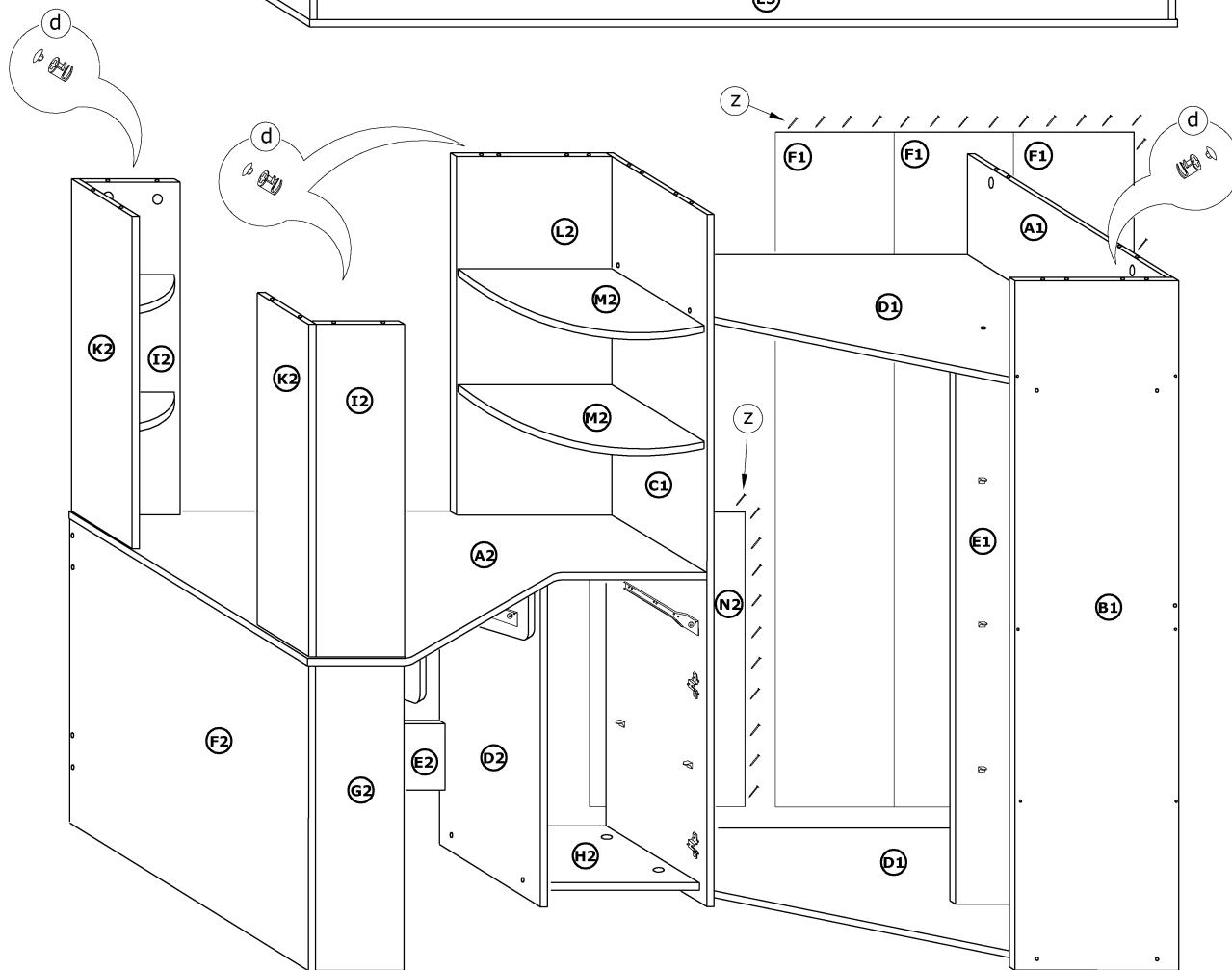
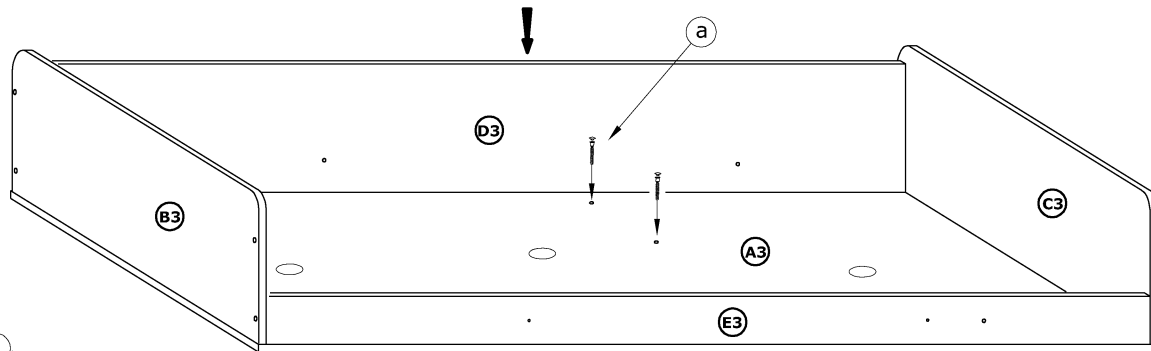

18

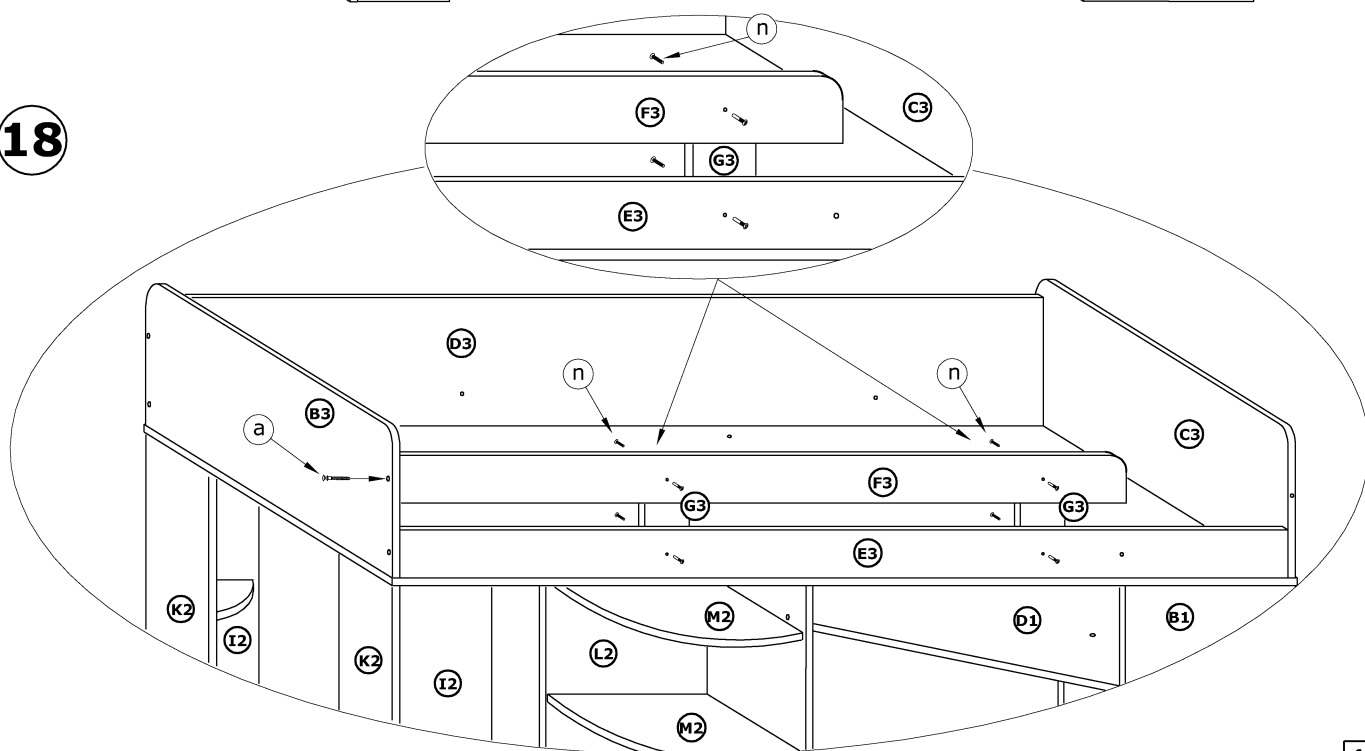

19

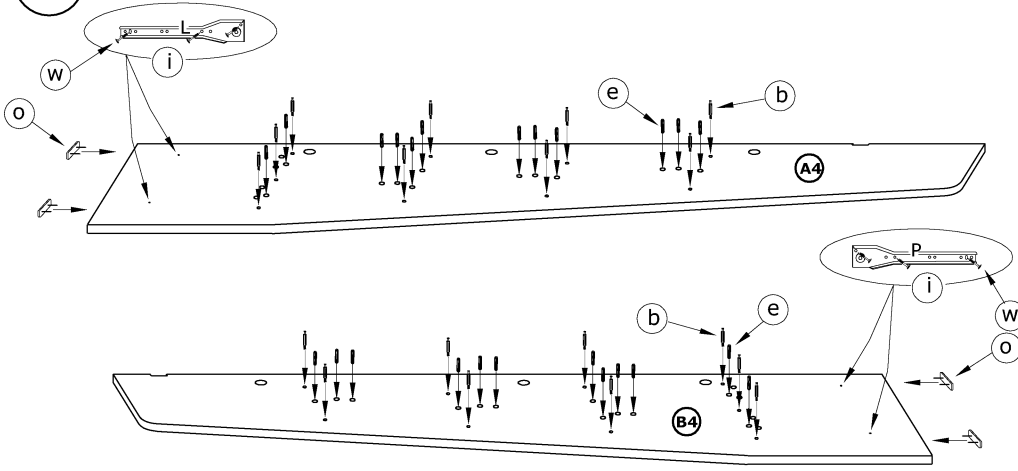

22

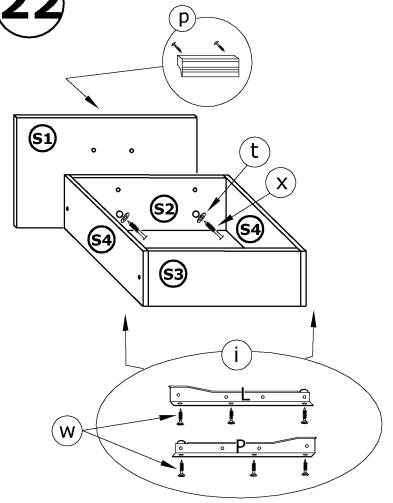

20

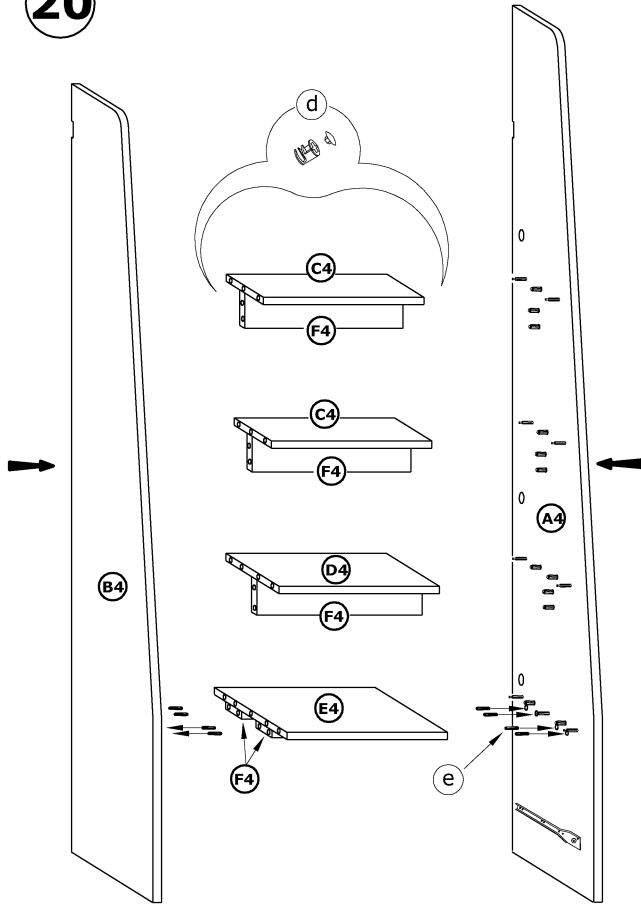

23

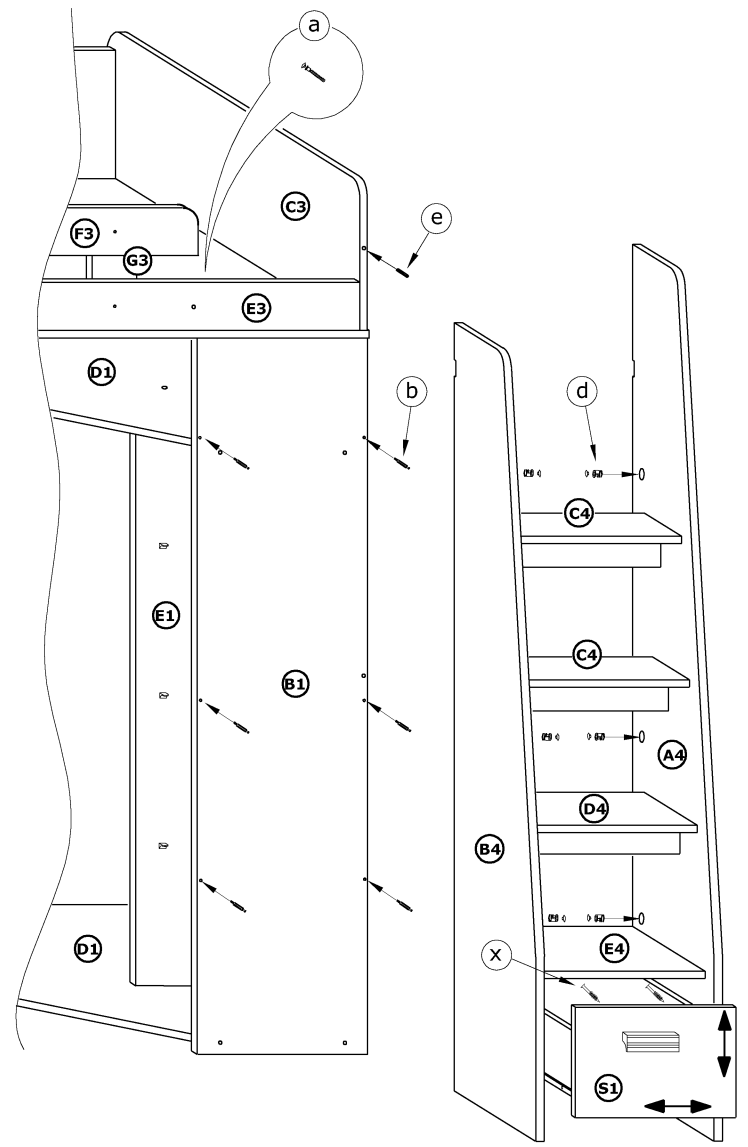

21

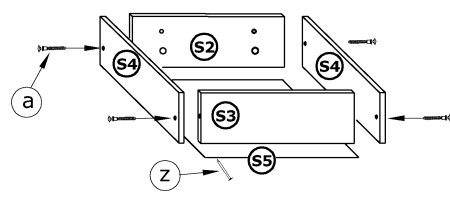

24

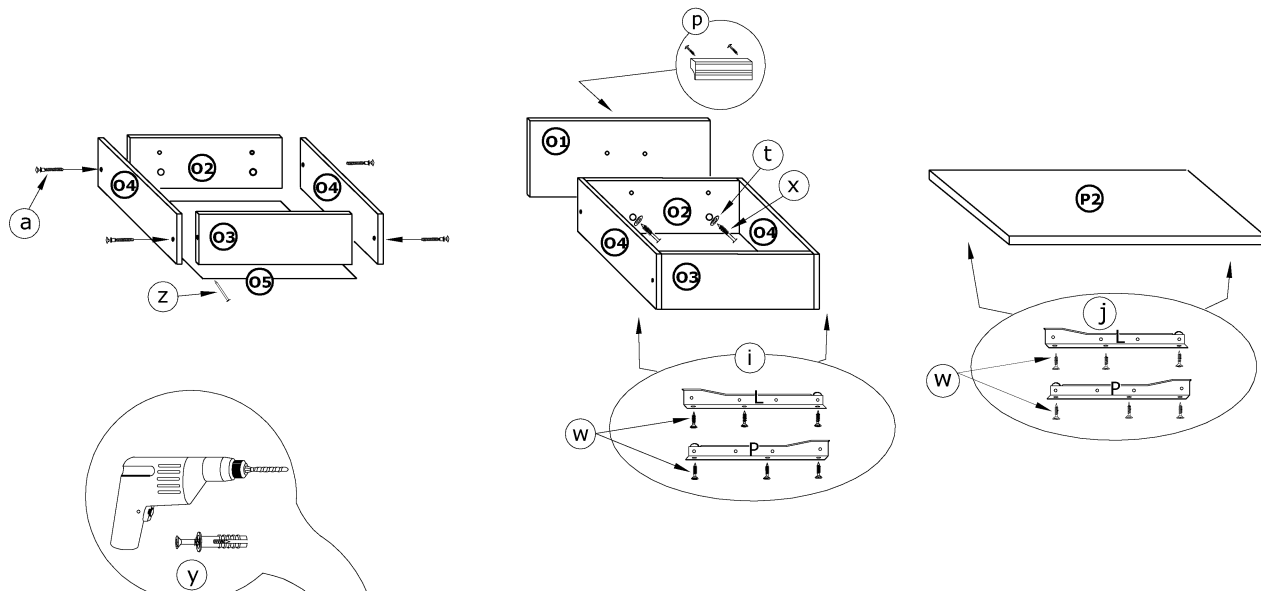

25

