

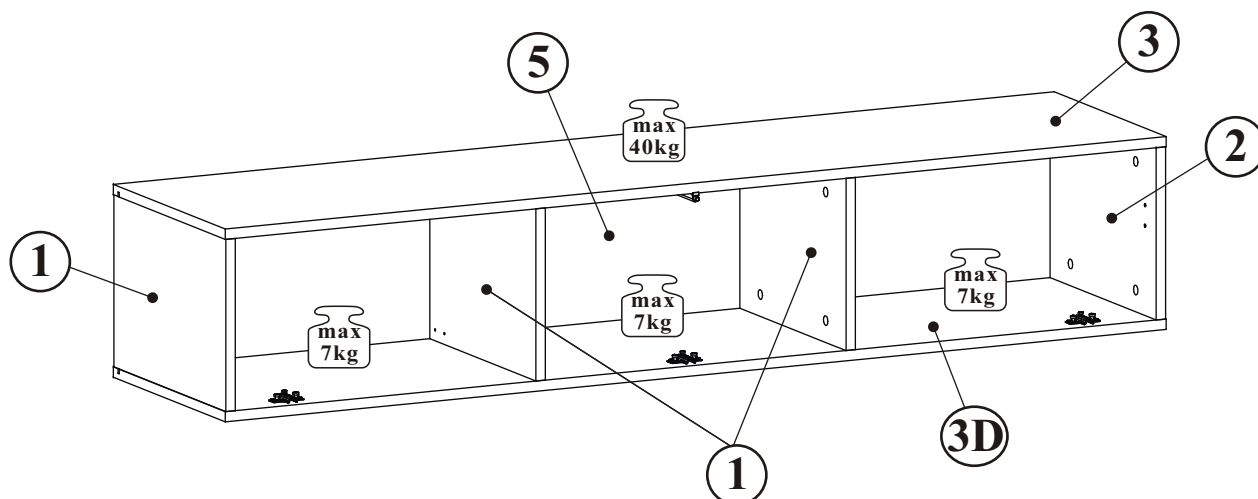

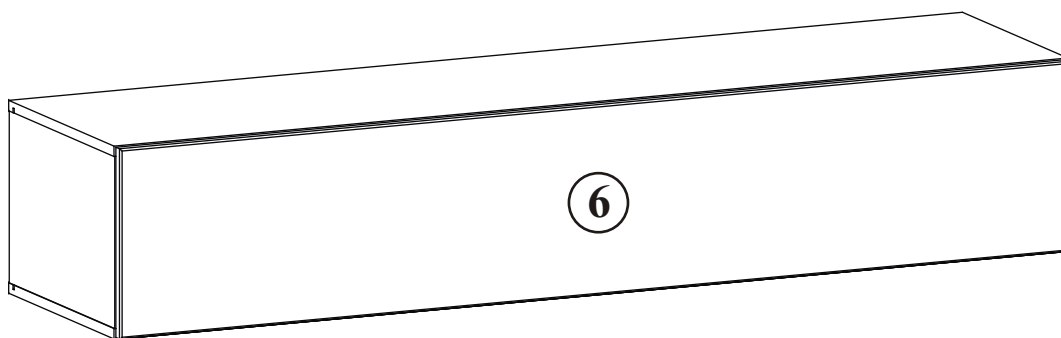

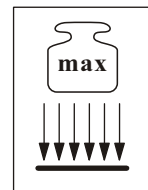

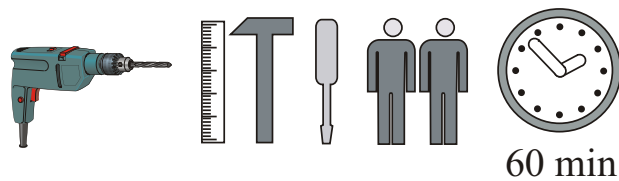

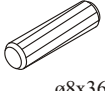
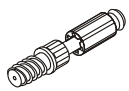

FLY 28 -- FY 30-C

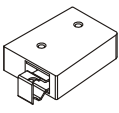

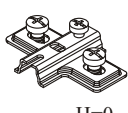
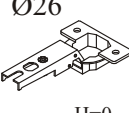
NO	Dim.		Col.-No	Qty
1	268	384	1	1
2	268	384	1	1
3	1602	384	1	1
3D	1602	384	1	1
4	268	364	1	2
5	1580	280	1	1
6	1596	296	1	1

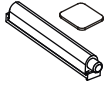

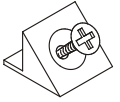
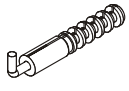
FLY 28--FY 30-C

A1 x16  ø8x36	B4 x16 	B5 x16  ø15x12	G5 x16 	ZR1 x4 	D6 x8  USØ3,5x30
E2 x3  H=0	E1 x3  Ø26 H=0	D10 x24  USØ3,5x13	AM x1 	G21 x2 	D7 x6  USØ3x16
S1 x12 	KR2 x4 	G2 x1 			

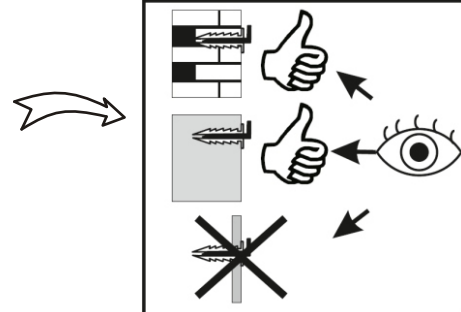
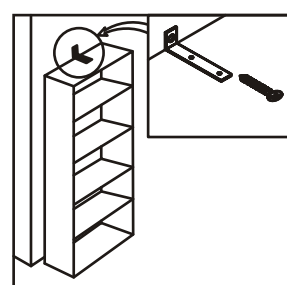
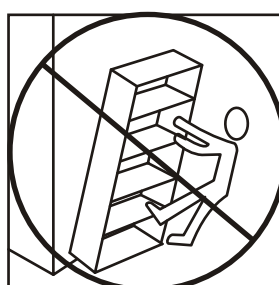
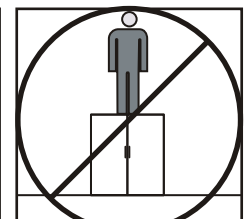
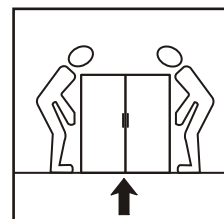
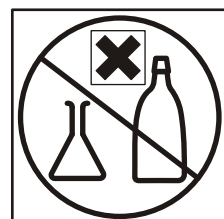
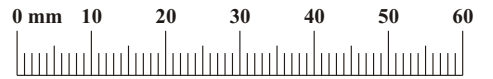

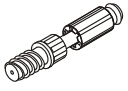
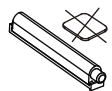
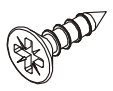
B4		AM		D10	
x8		x1		x2	US03,5x13

1

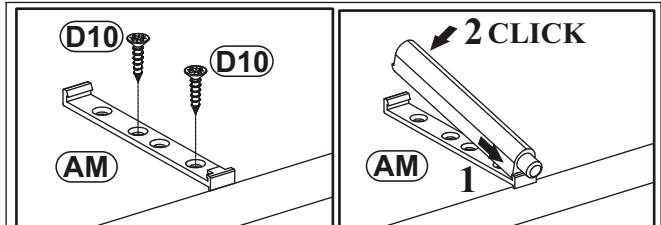
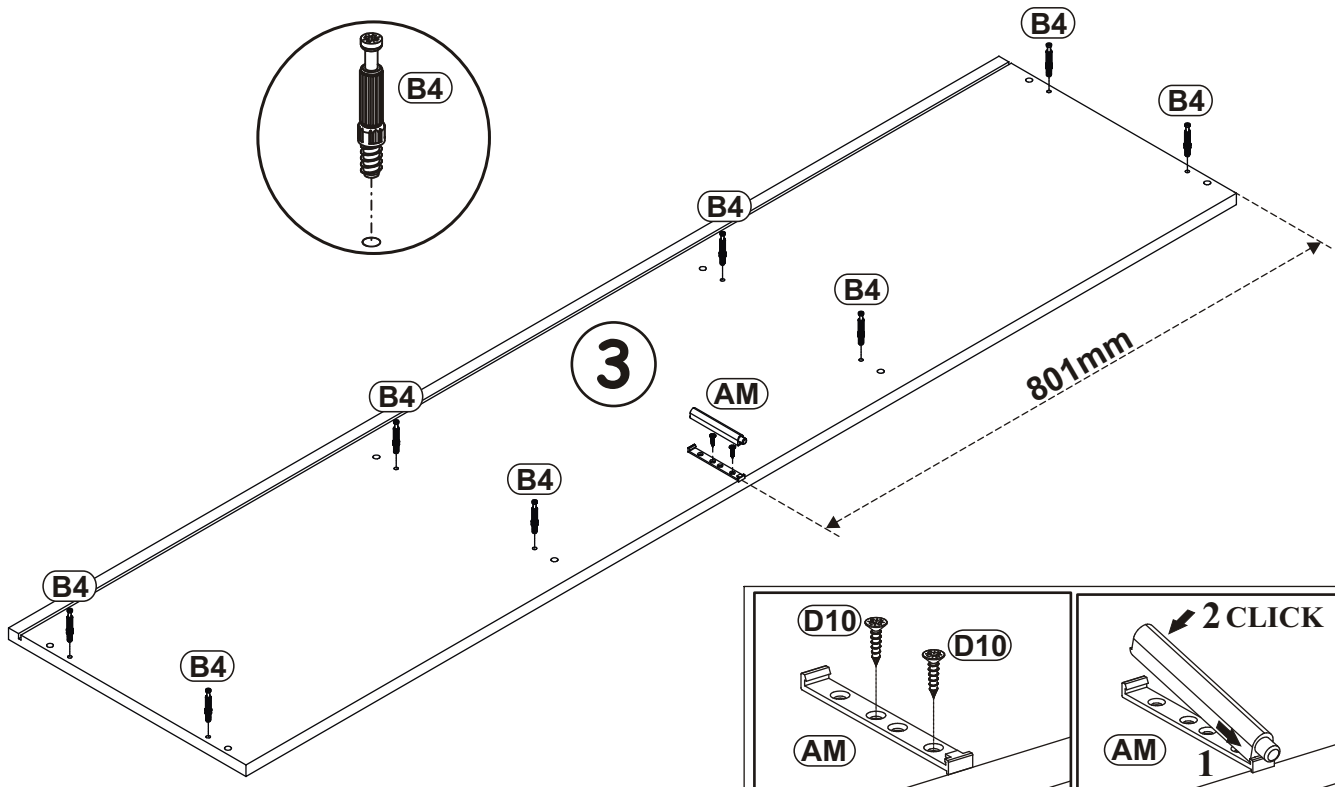

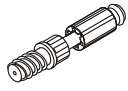
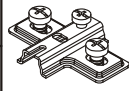

2

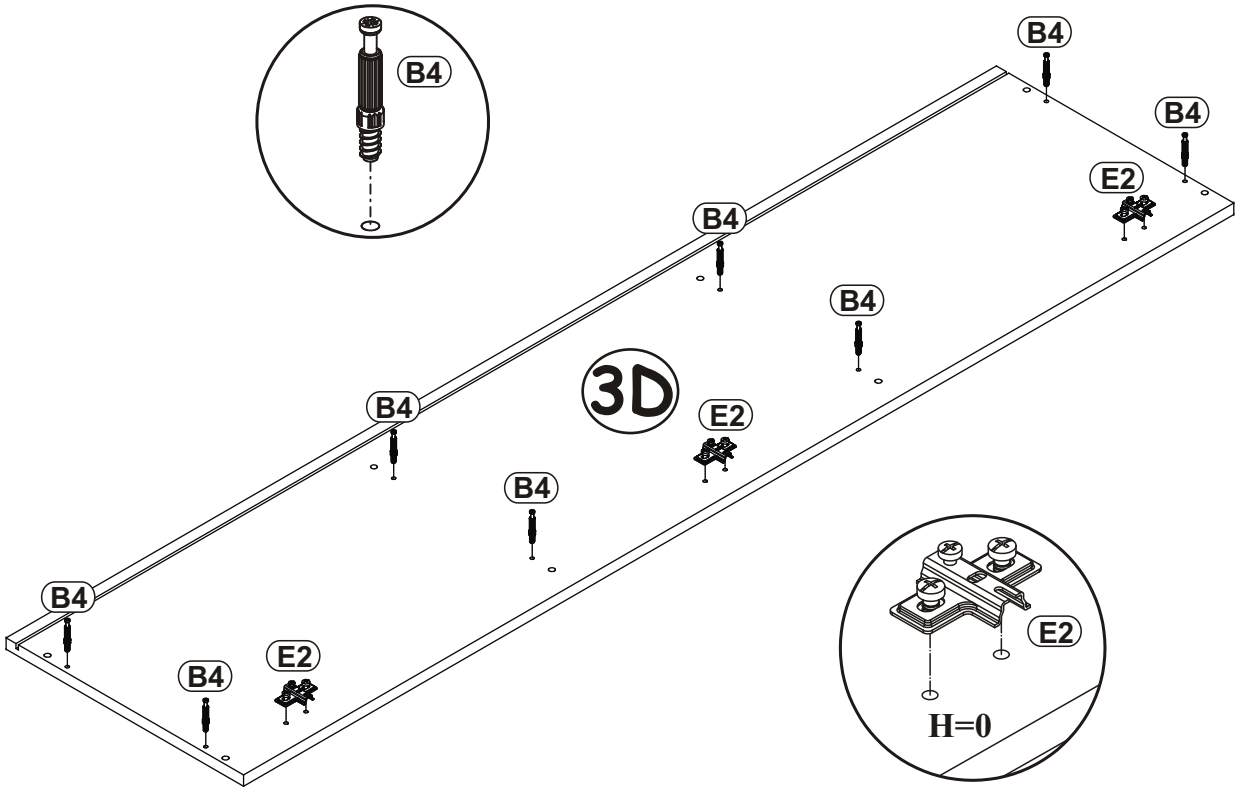
B4		E2	
x8		x3	H=0



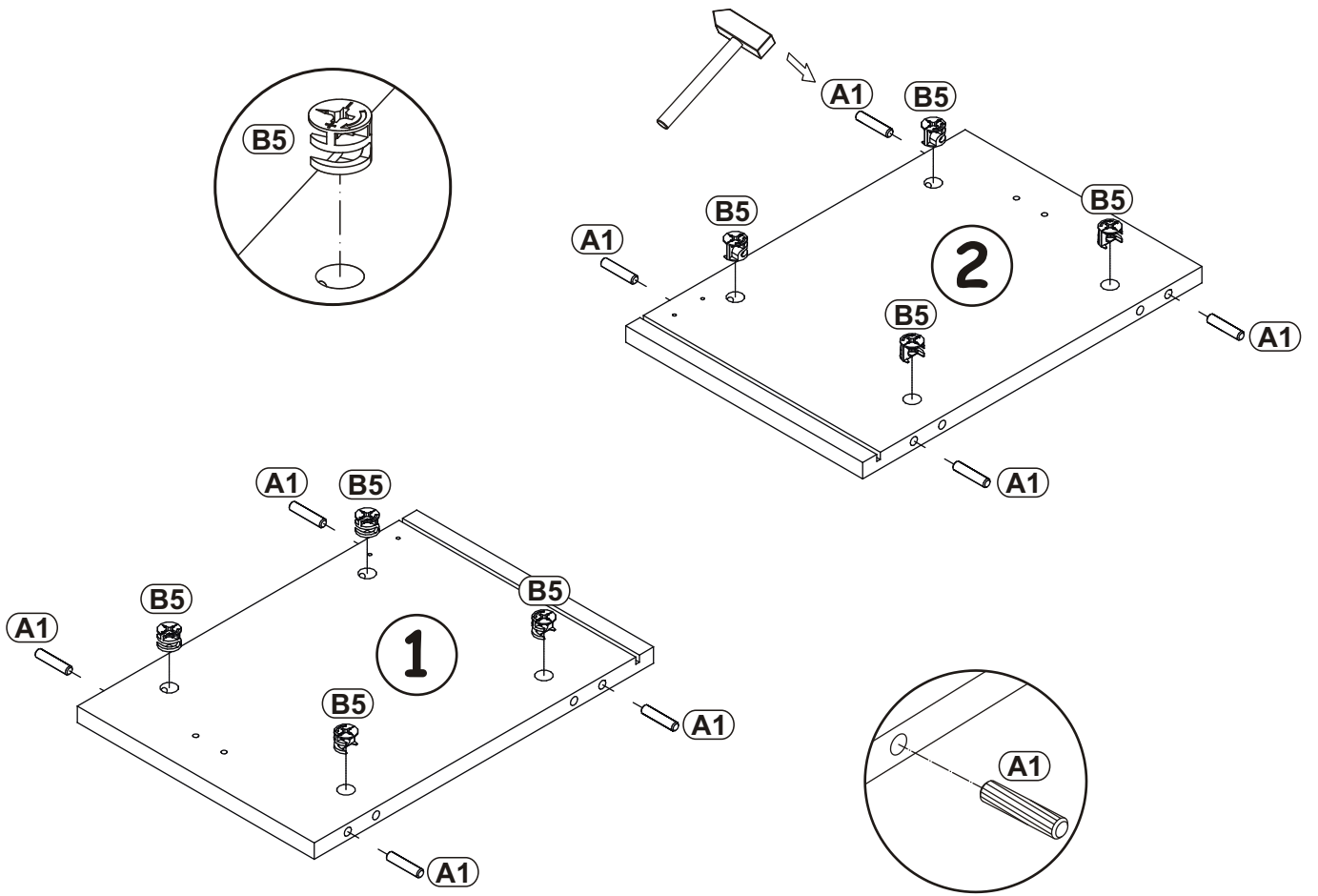

3

A1		B5	
x8	ø8x36	x8	ø15x12



4

A1		B5	
x8	ø8x36	x8	ø15x12

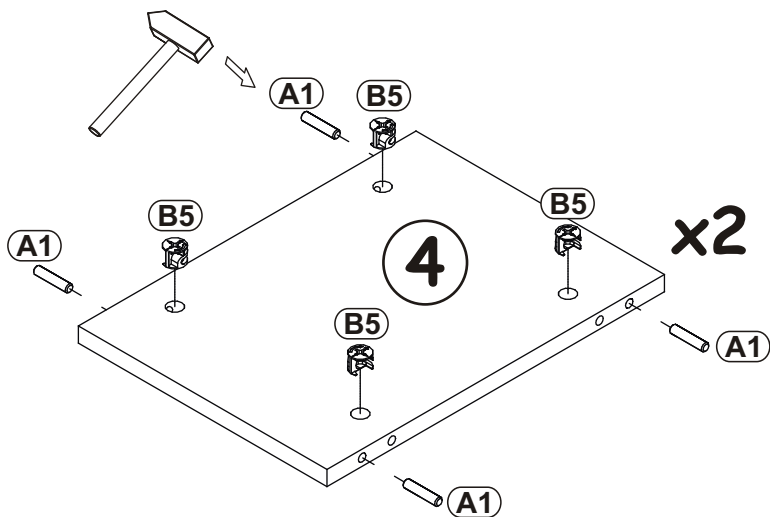

5

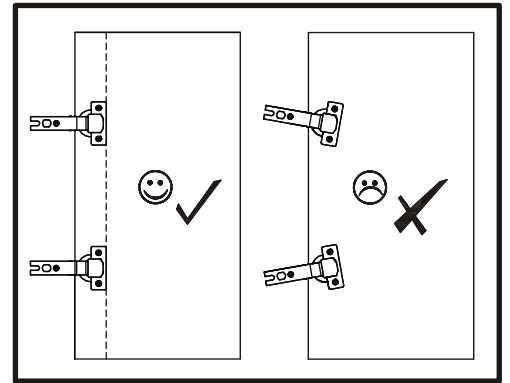
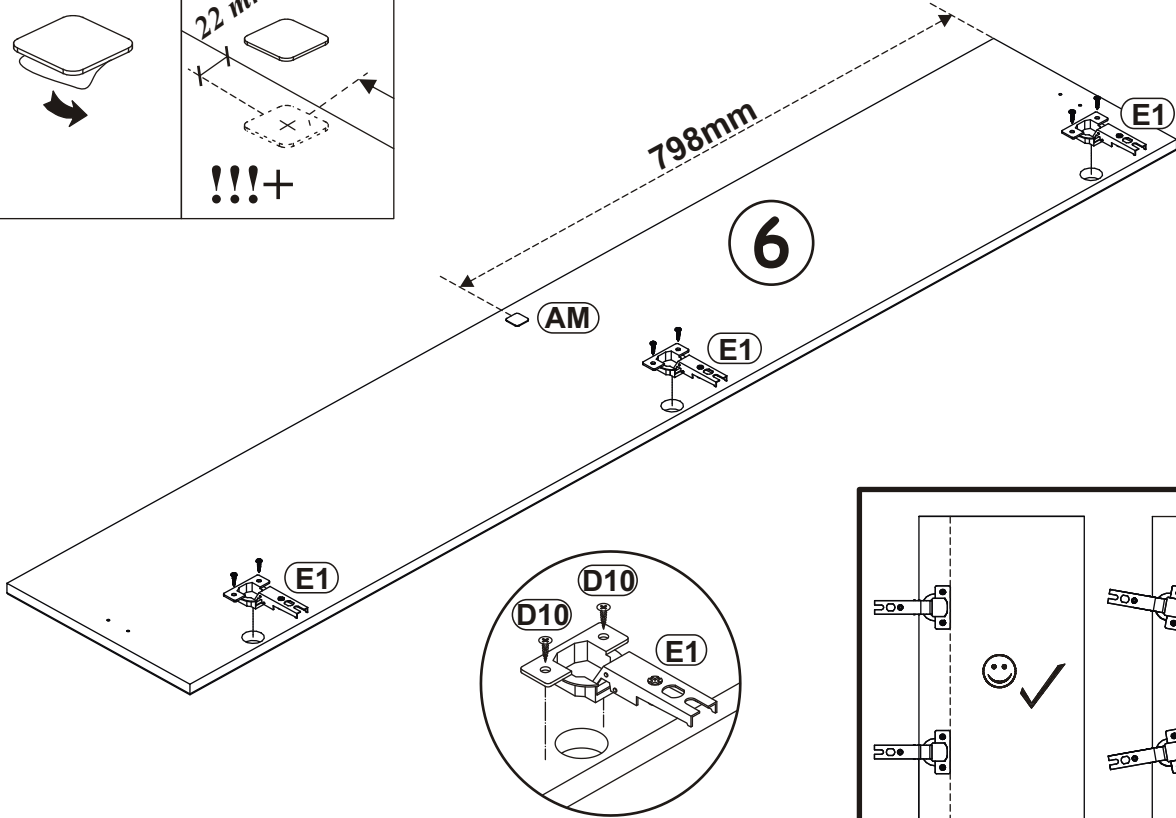
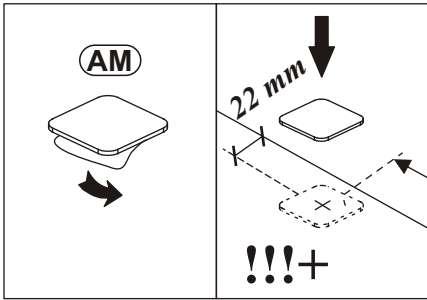
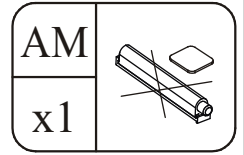
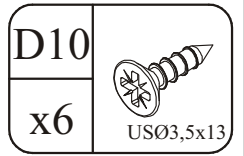
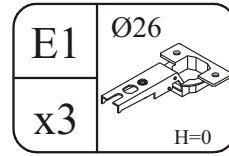
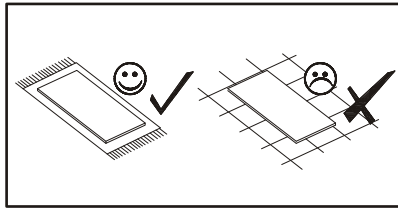

6

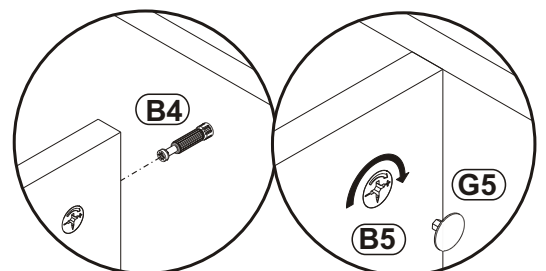
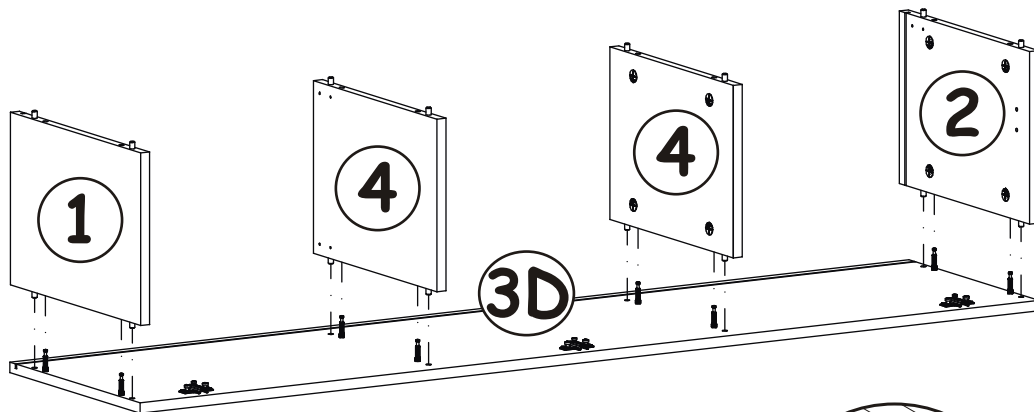
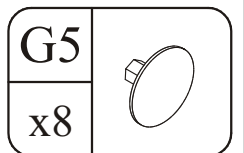

7

G5	
x8	

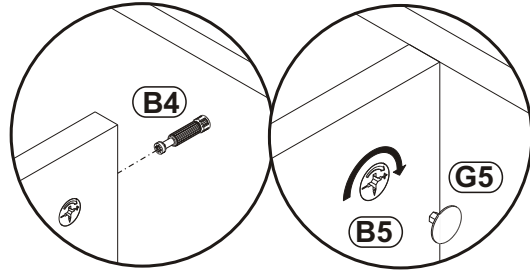
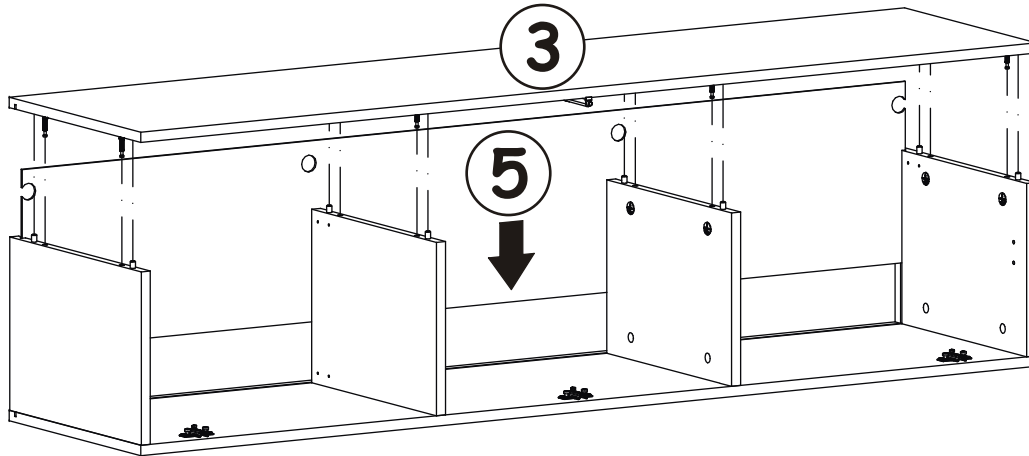



8

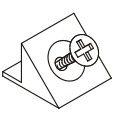

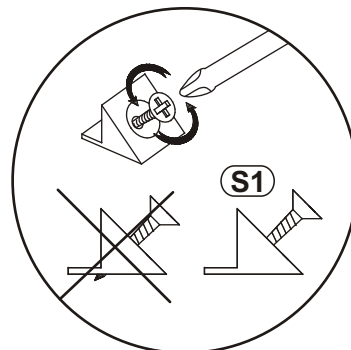
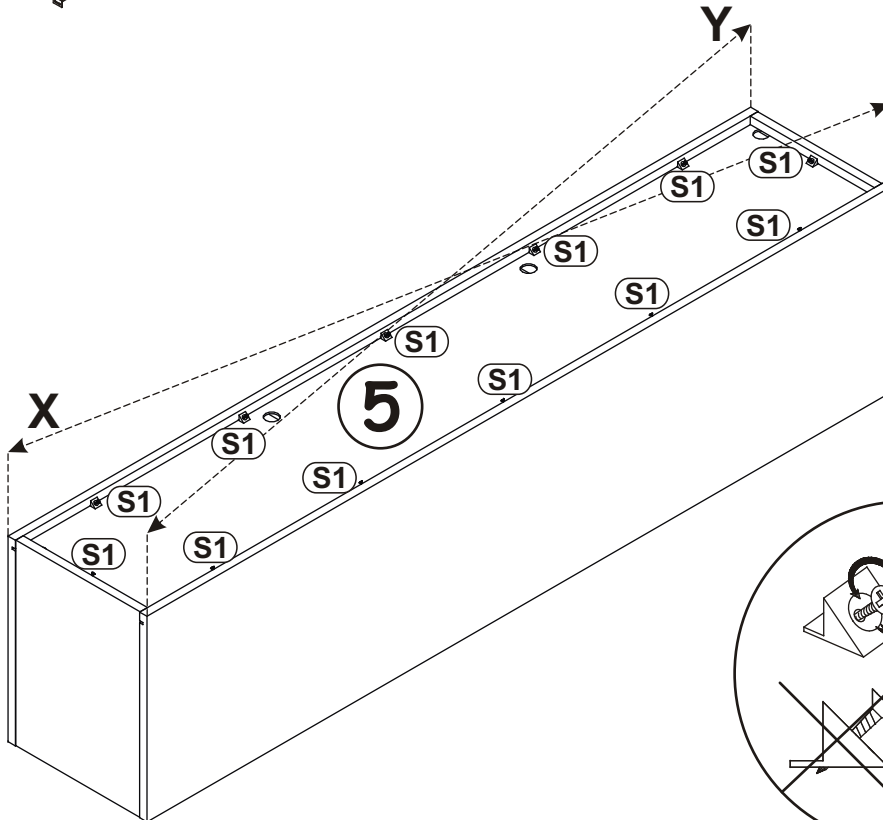
S1	
x12	

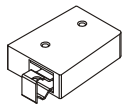

9

ZR1		D6	
x4		x8	USØ3,5x30

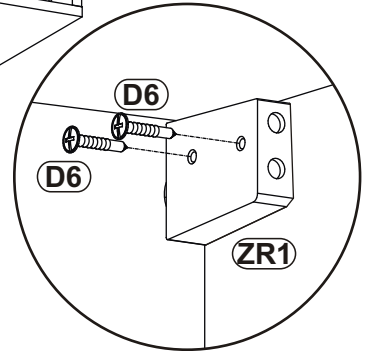
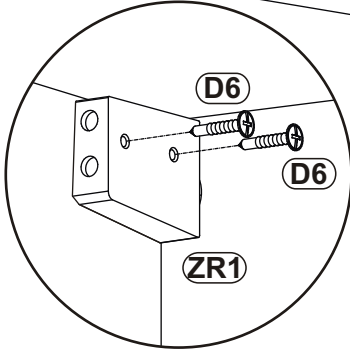
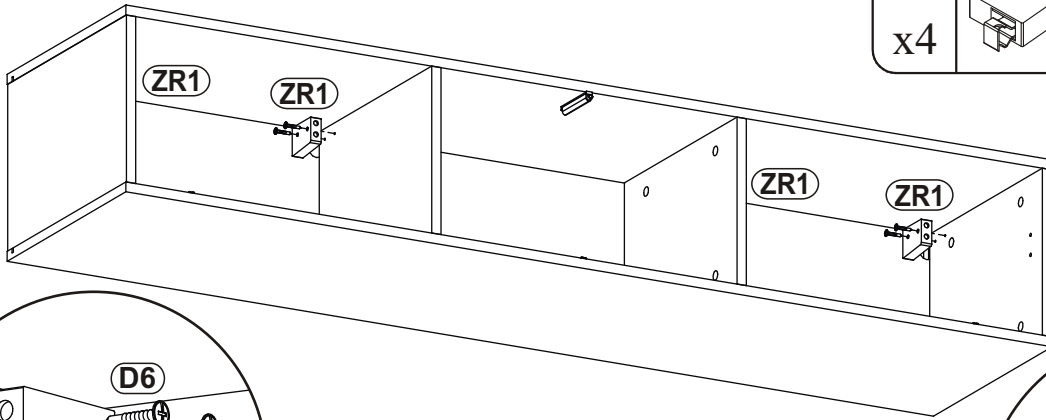

10

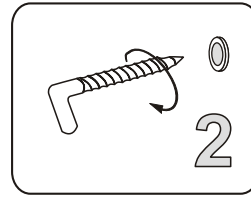
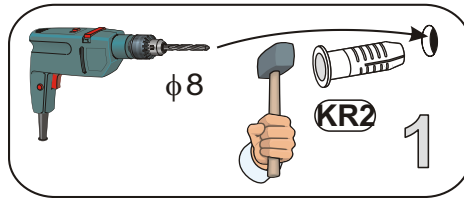
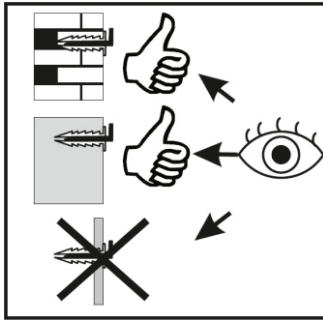

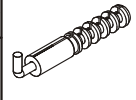
KR2	
x4	

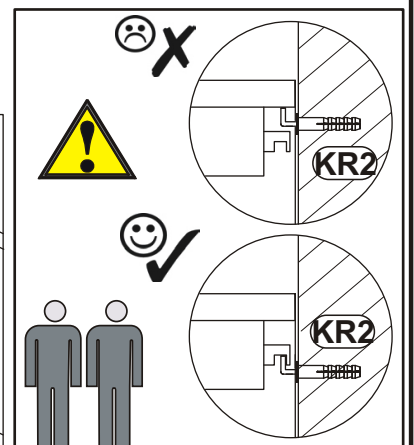
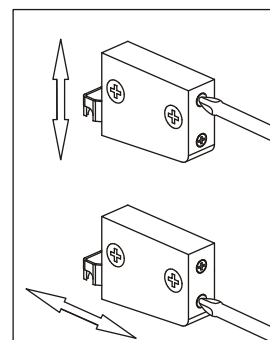
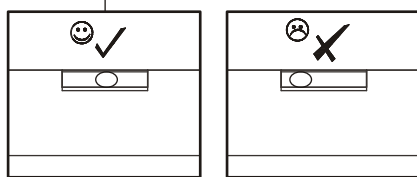
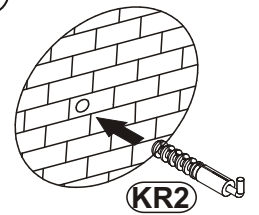
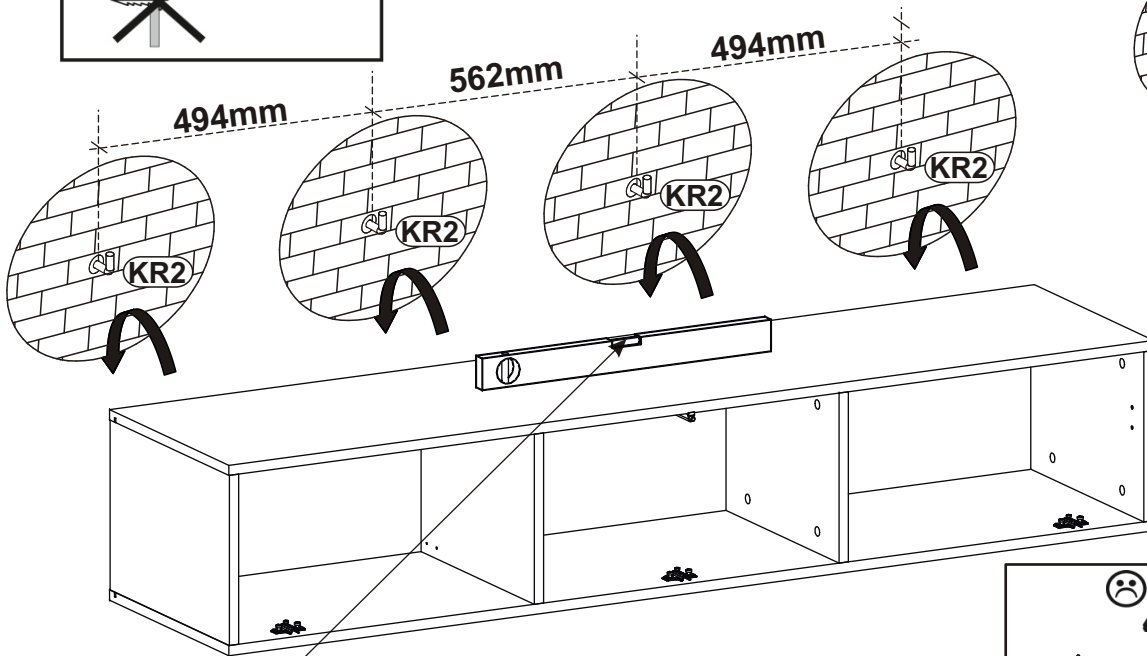

11

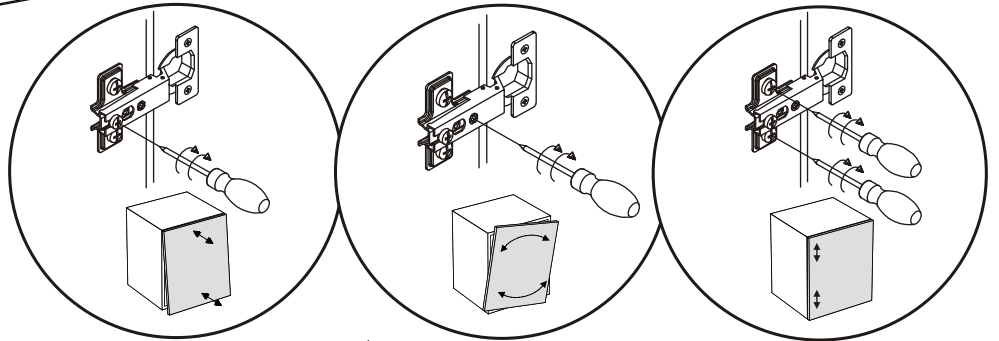
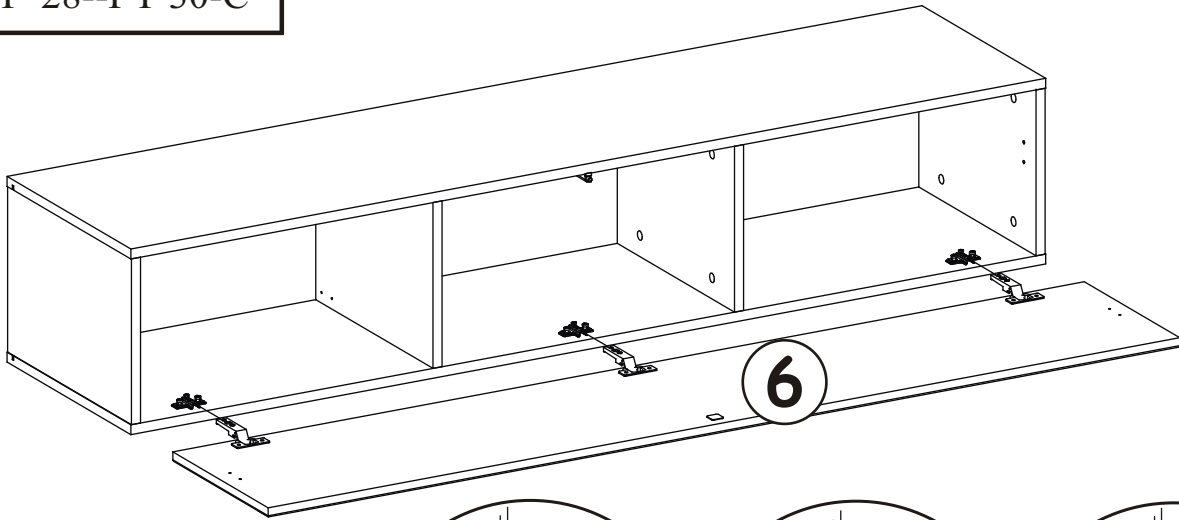

12

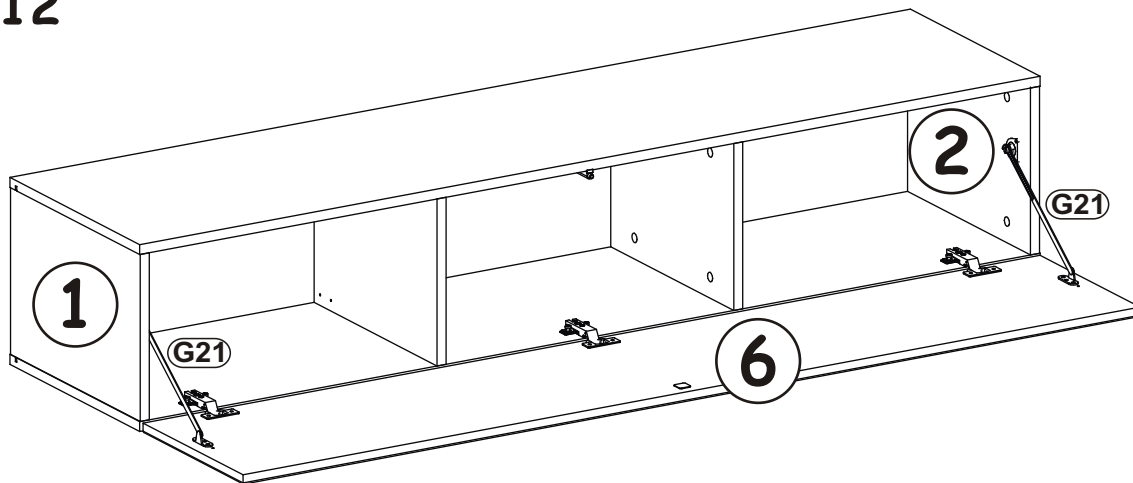

- | | |
|-----|-----------|
| G21 | |
| x2 | |
| D7 | |
| x6 | USØ3x16 |
| D10 | |
| x6 | USØ3,5x13 |

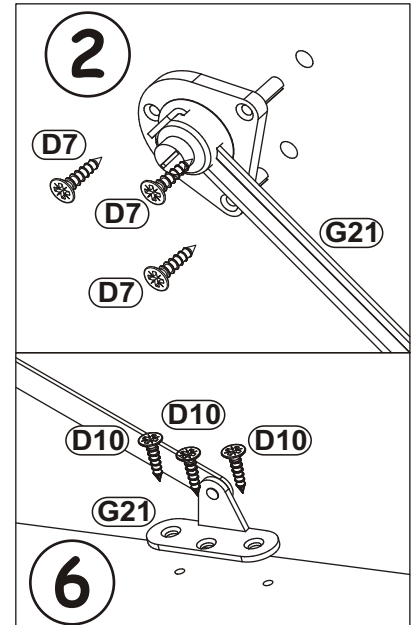
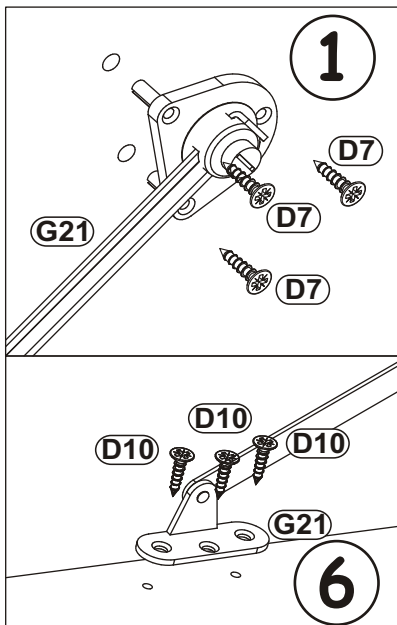



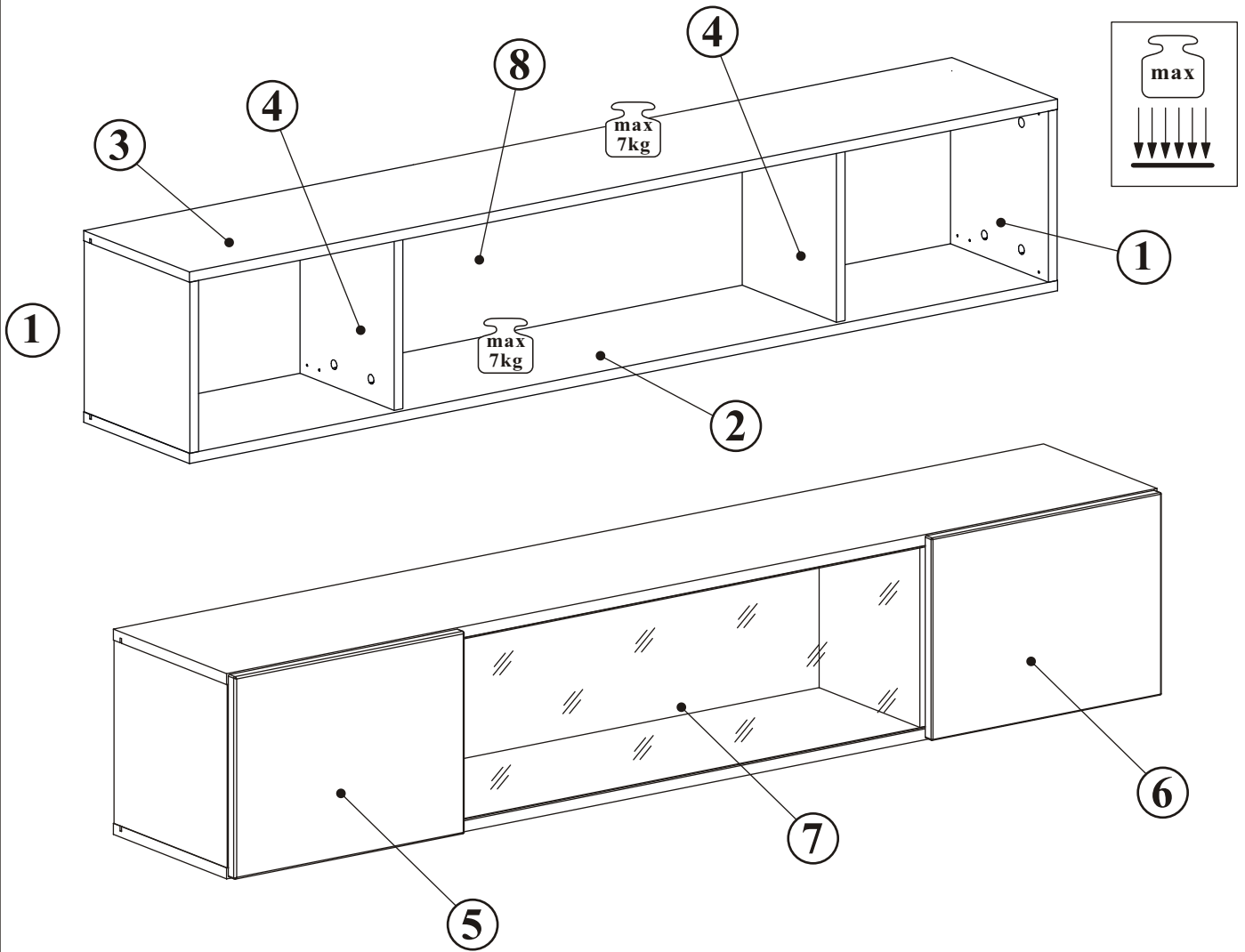



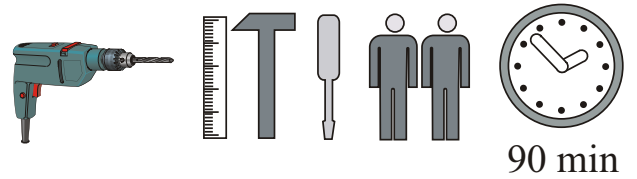

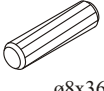
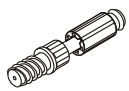

FLY 28 -- FY 52B-C

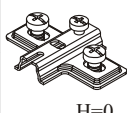
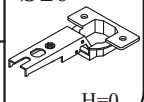

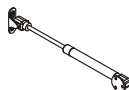
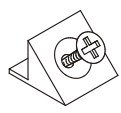
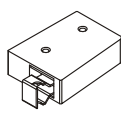
NO	Dim.		Col.-No	Qty
1	268	274	1	2
2	1602	274	1	1
3	1602	274	1	1
4	268	244	1	2
8	1580	280	1	1
5	396	296	1	1
6	396	296	1	1
7	854	264	1	1

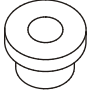

FLY 28--FY 52B-C

A1 x16  ø8x36	B4 x16 	B5 x16  ø15x12	G5 x16 	E2 x4  H=0	E1 x4  Ø26 H=0
T1 x2 	BO1 x2 	S1 x12 	ZR1 x4 	D6 x8  USØ3,5x30	D10 x22  USØ3,5x13
UP13 x10  UPØ3x16	G2 x1 	KR2 x4 	P2 x6 		

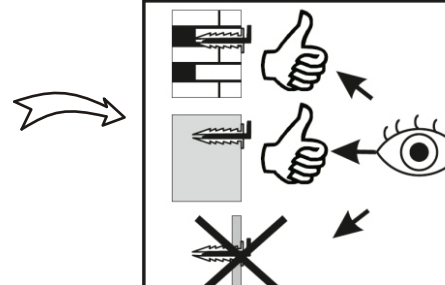
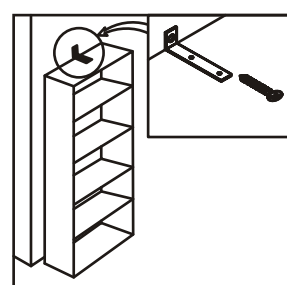
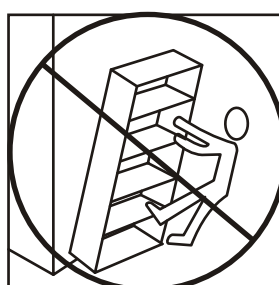
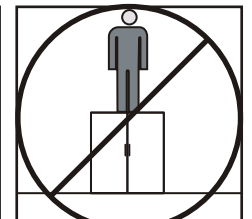
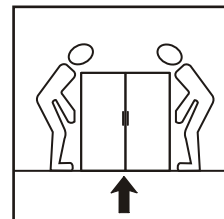
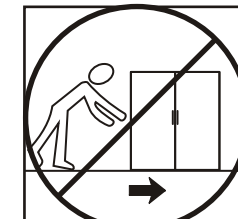
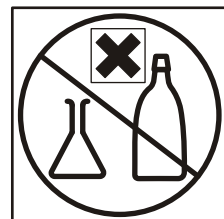
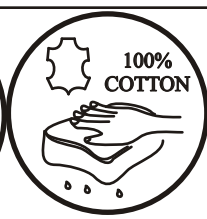
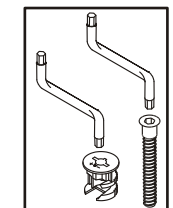
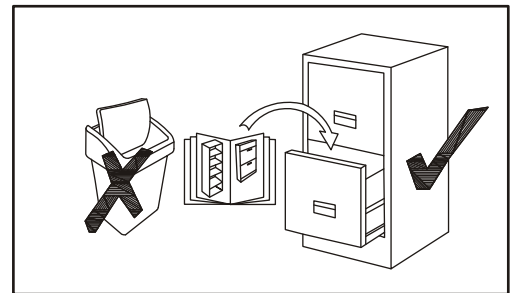
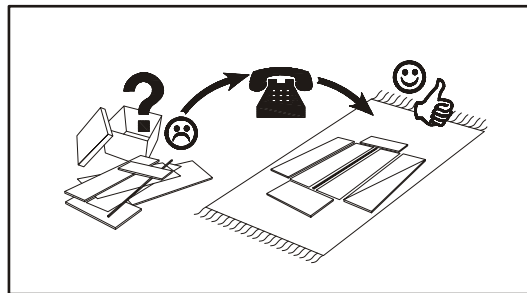
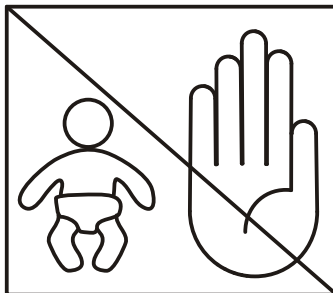
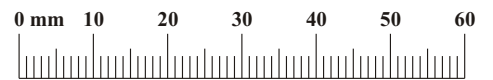

B5		A1	
x16	ø15x12	x16	ø8x36

1

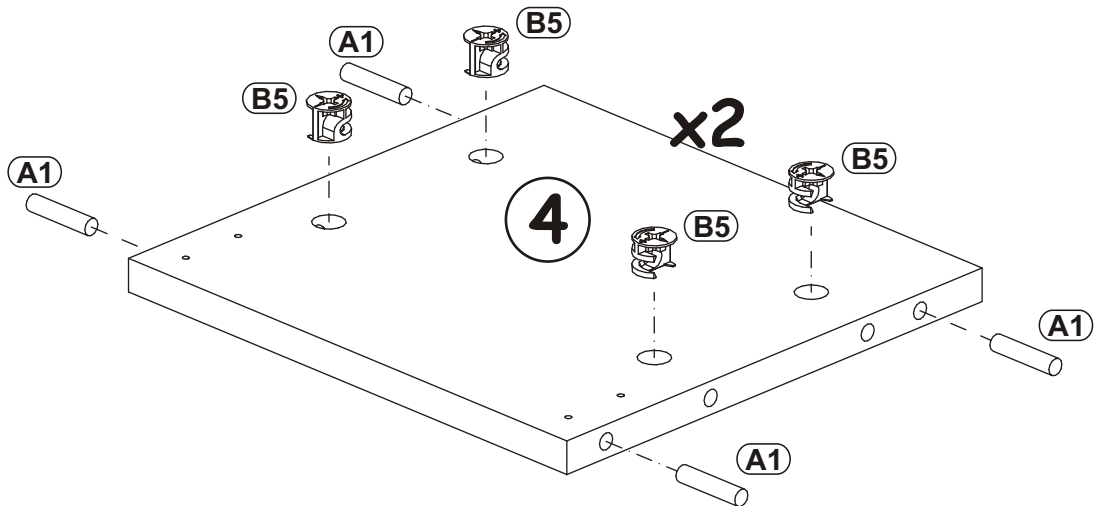
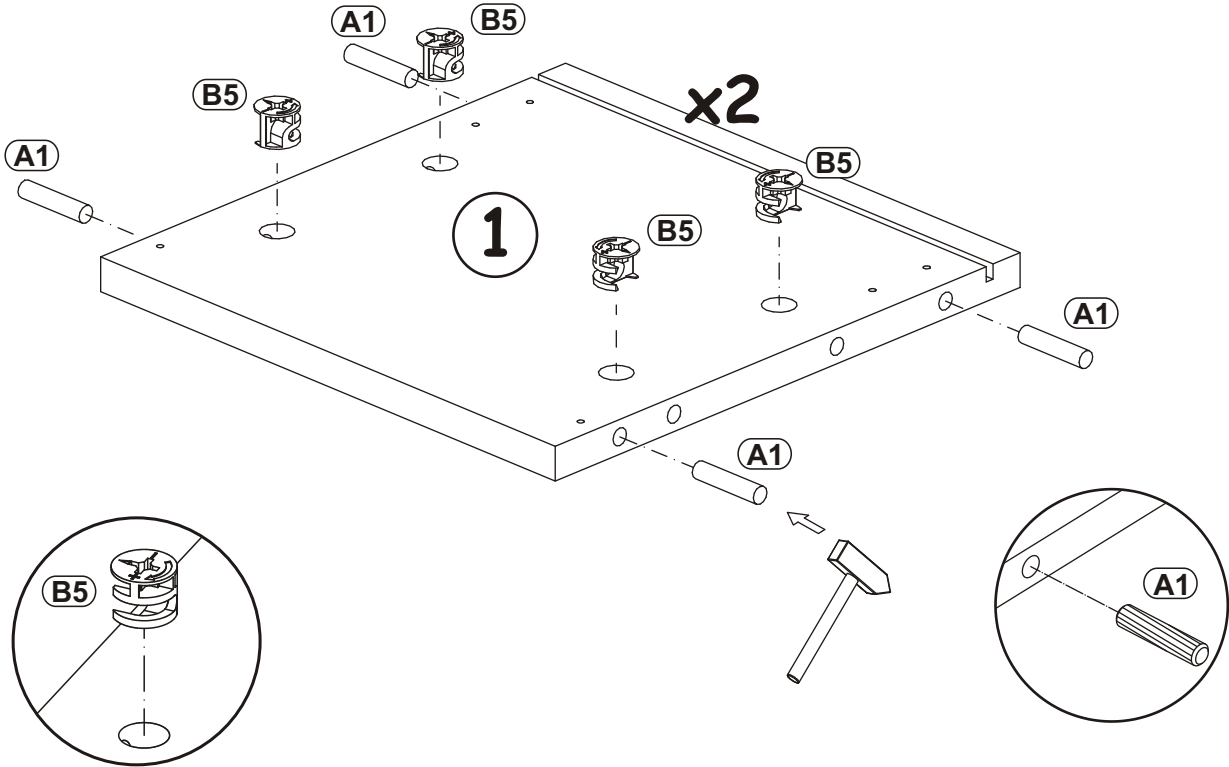

2

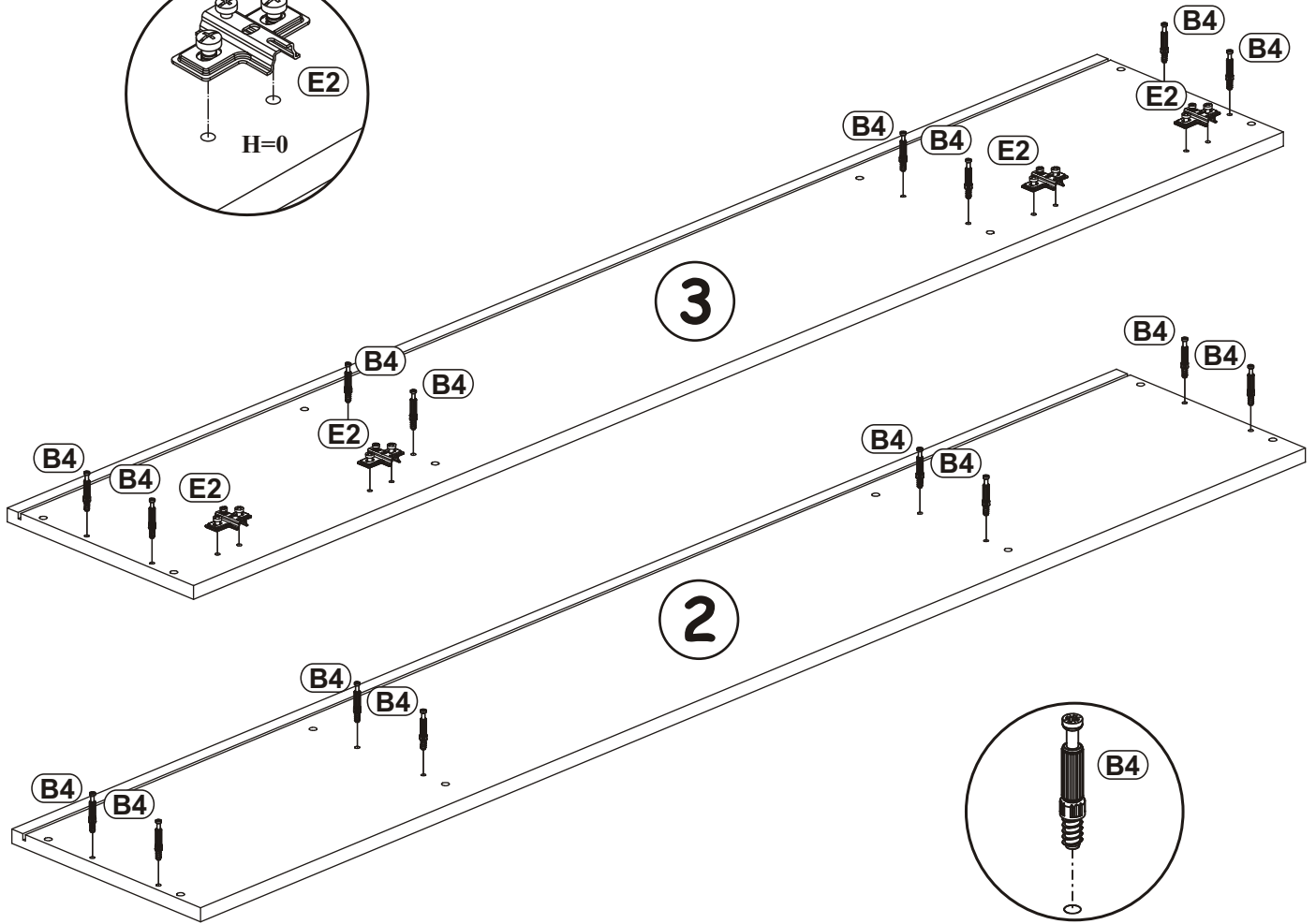
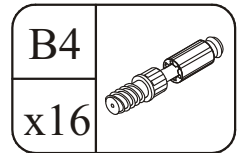
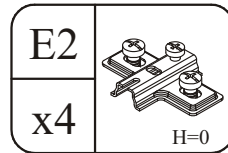
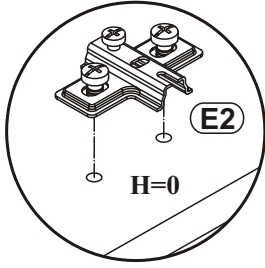

3

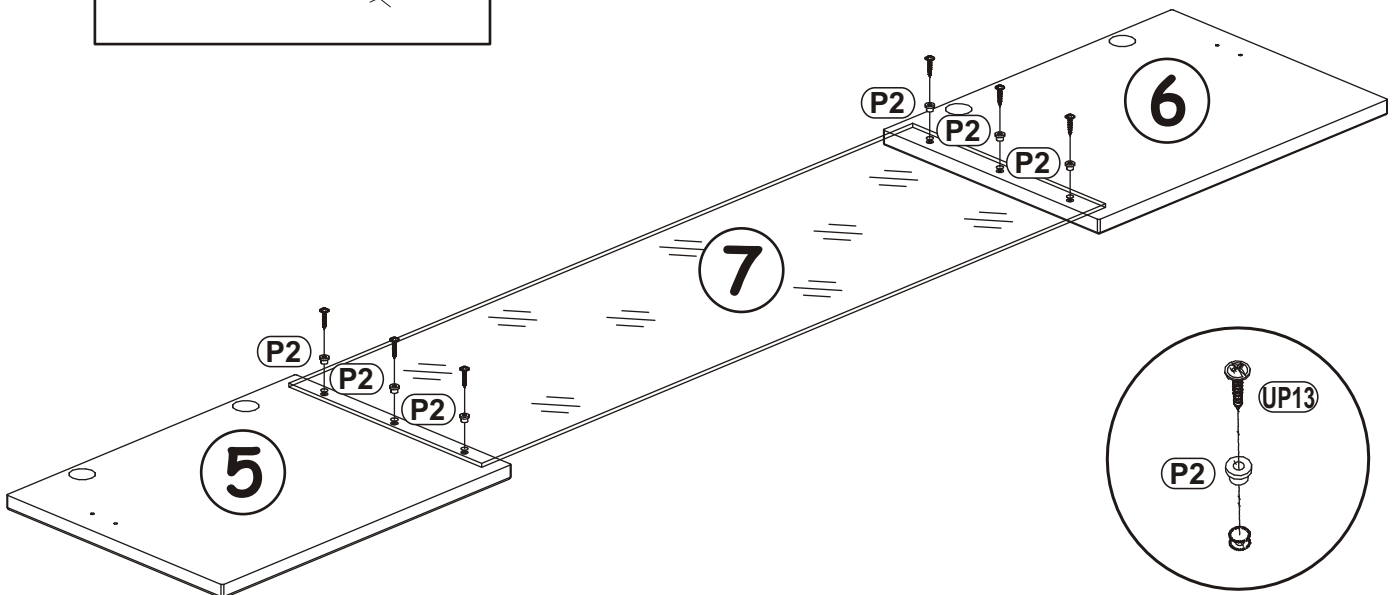
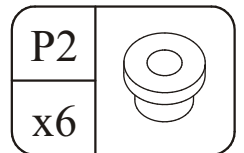
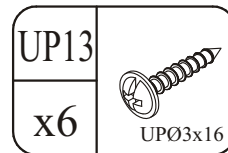
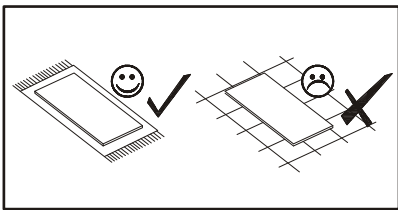

4

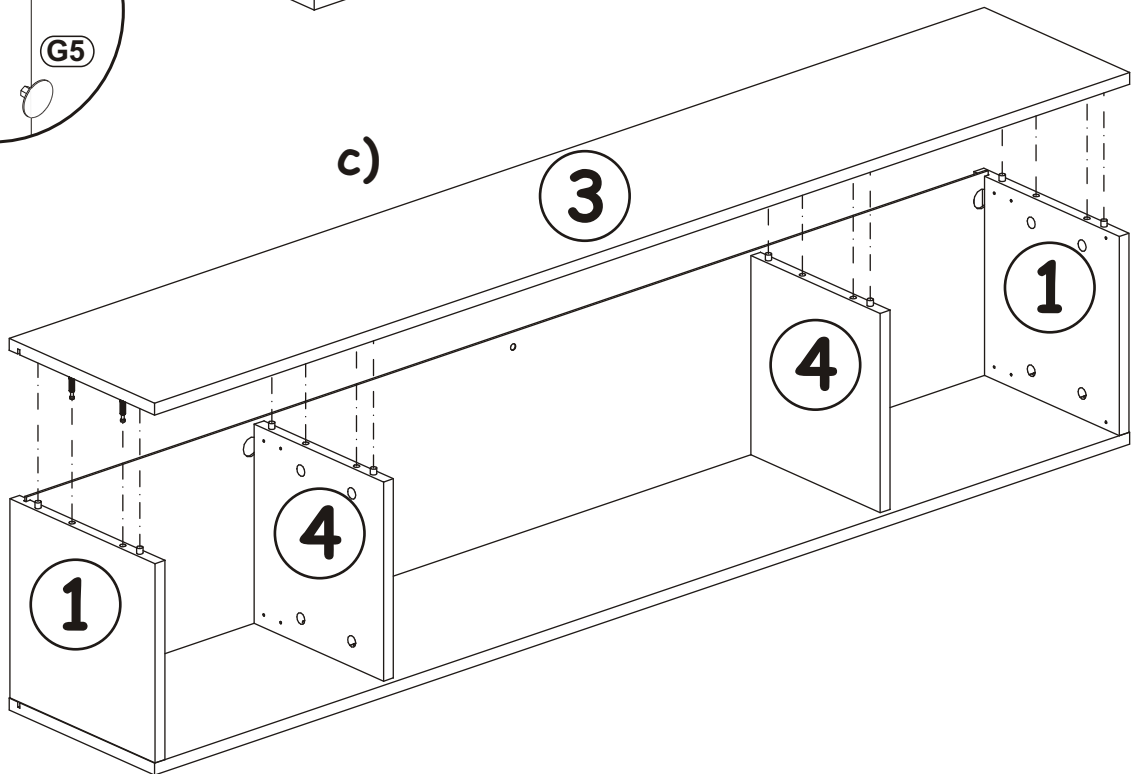
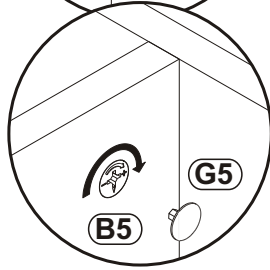
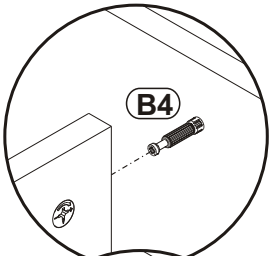
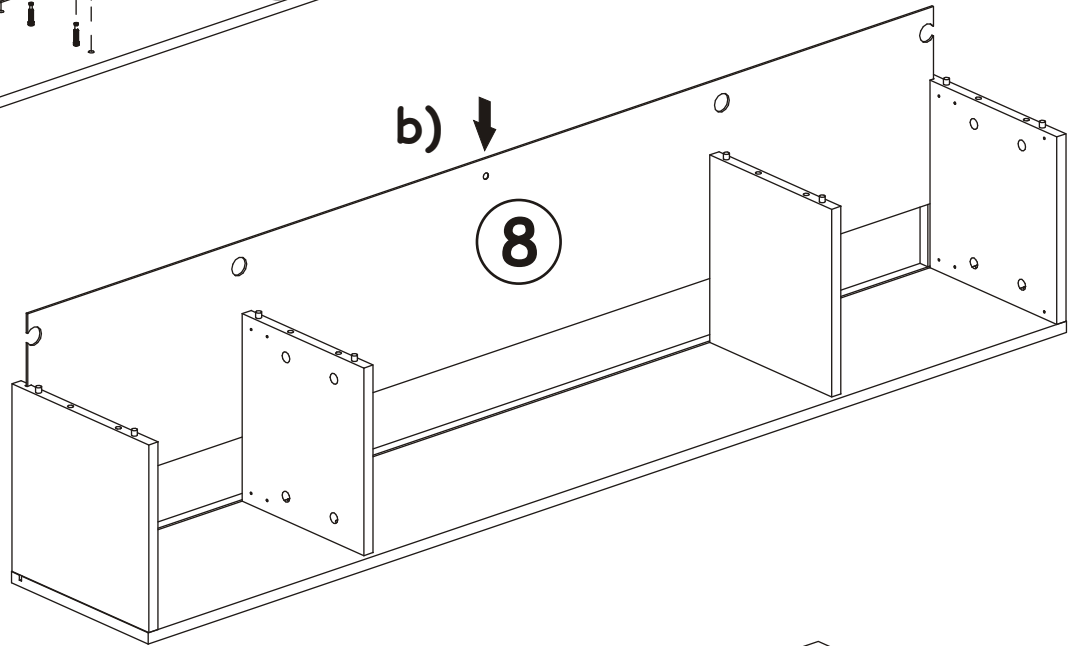
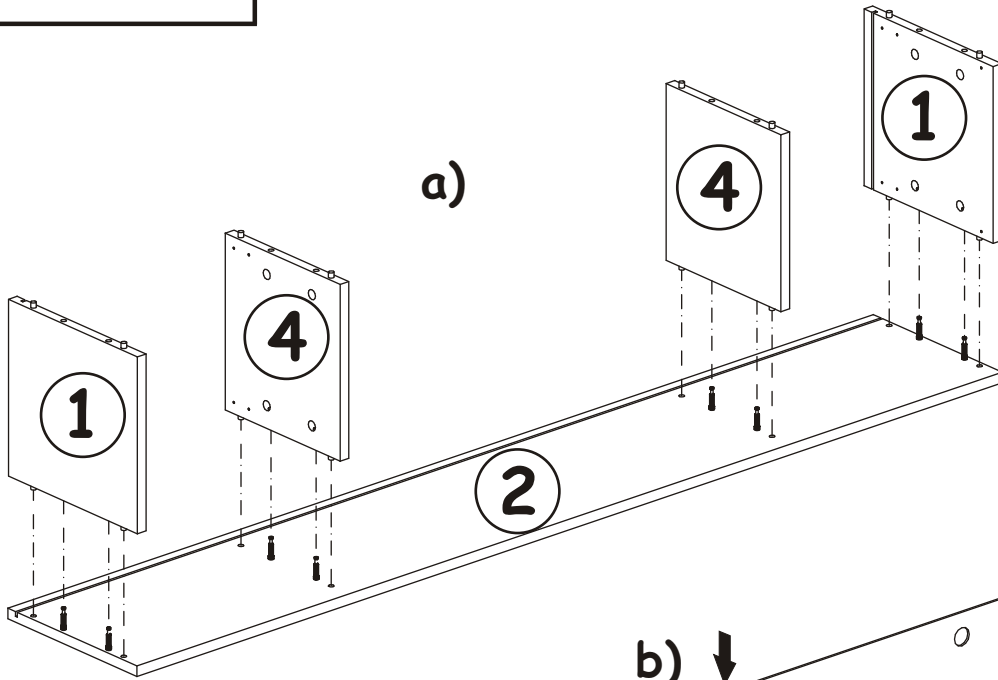
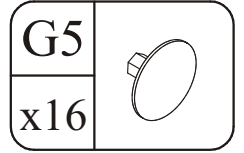

5

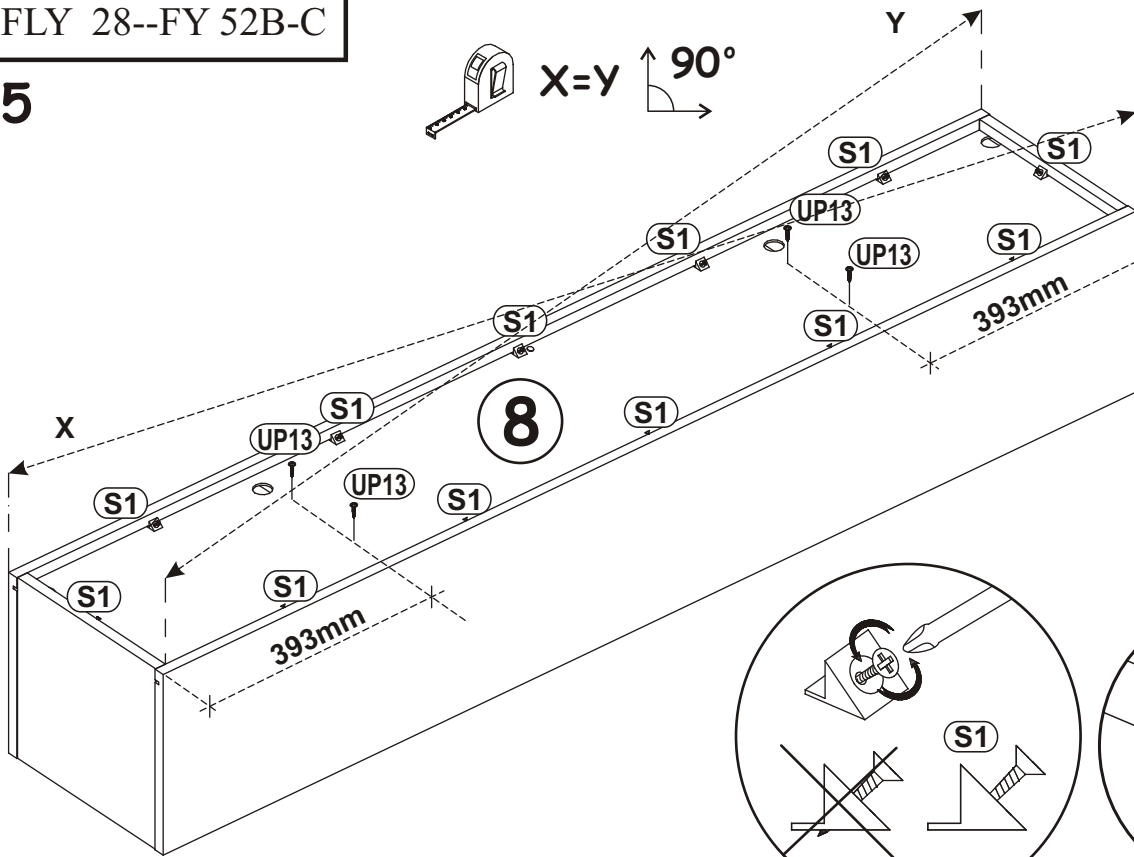

UP13	
x4	UP03x16

S1	
x12	

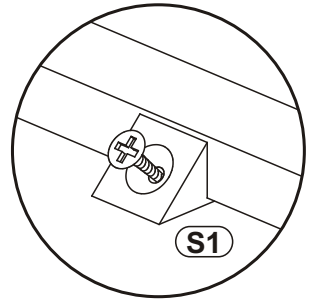
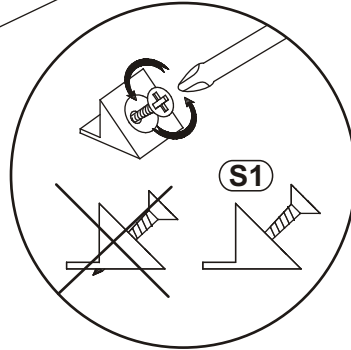
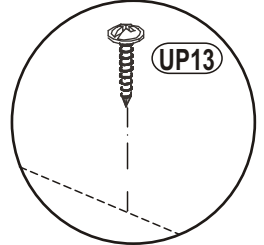

6

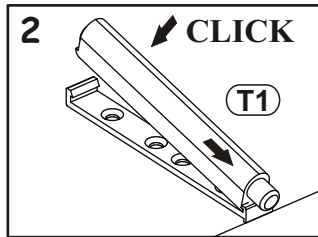
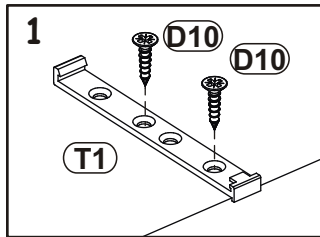

ZR1	
x2	

D6	
x4	US03,5x30

D10	
x4	US03,5x13

T1	
x2	

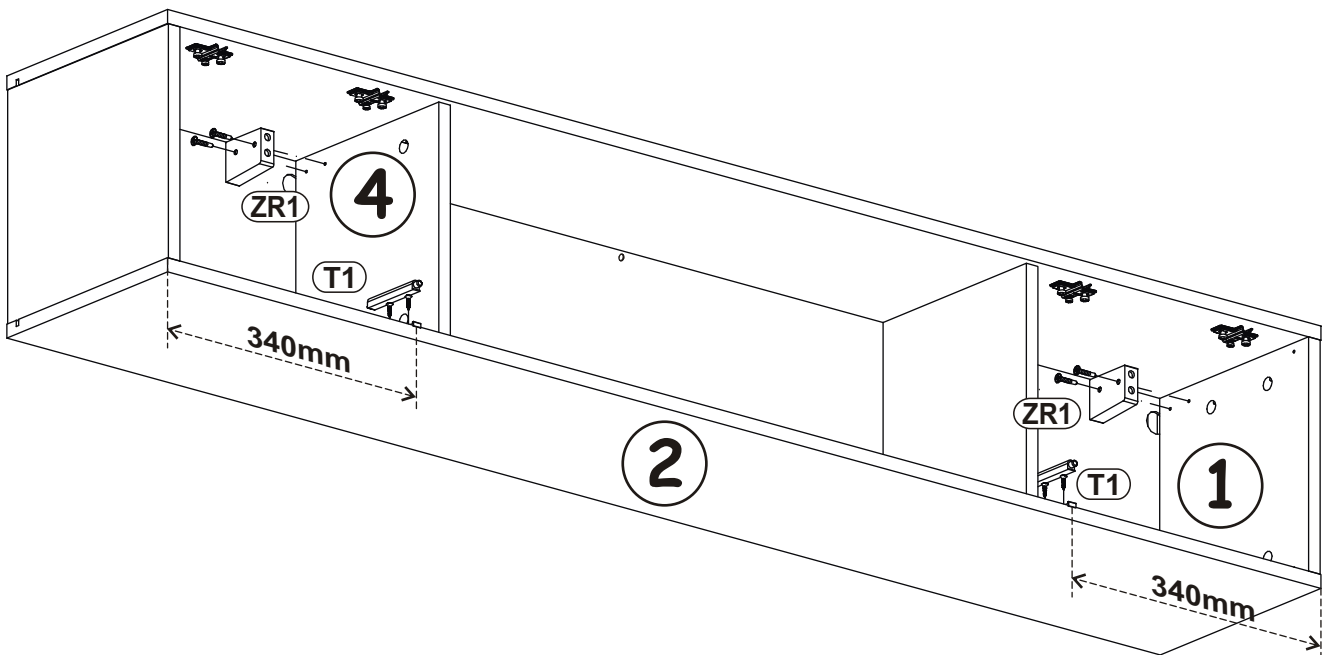

7

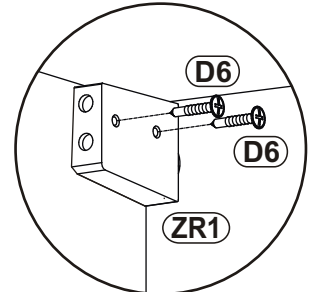
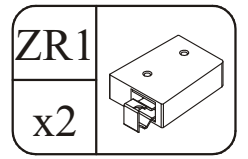
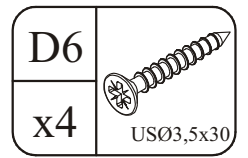
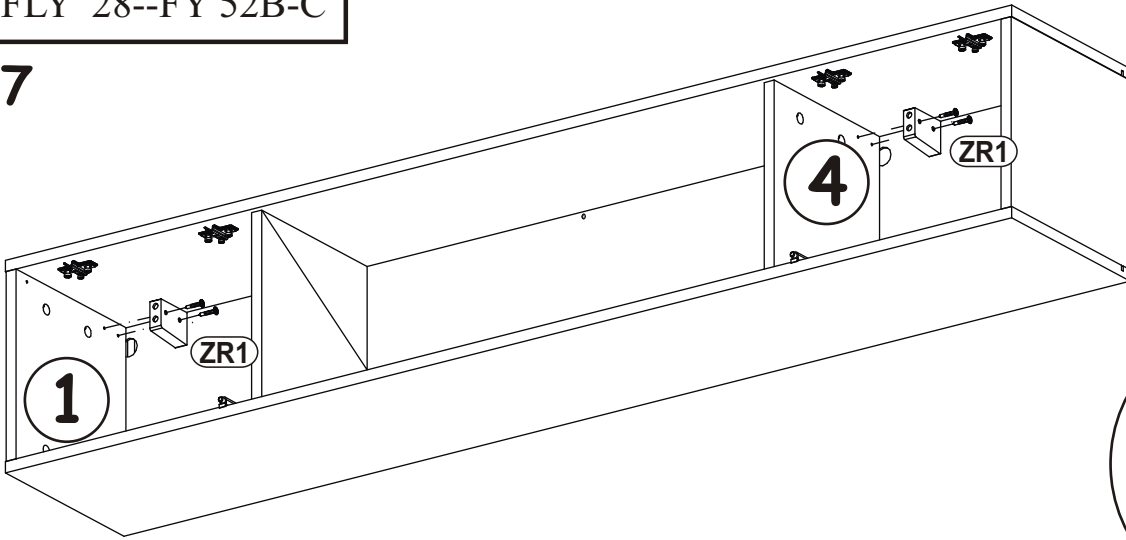

8

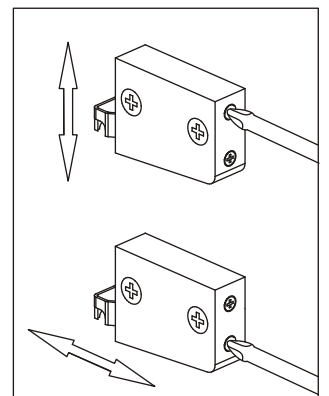
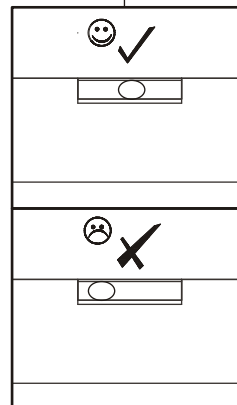
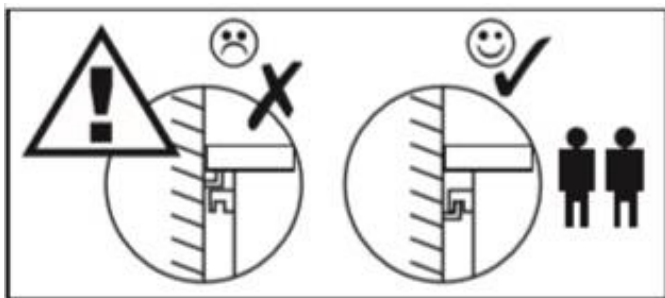
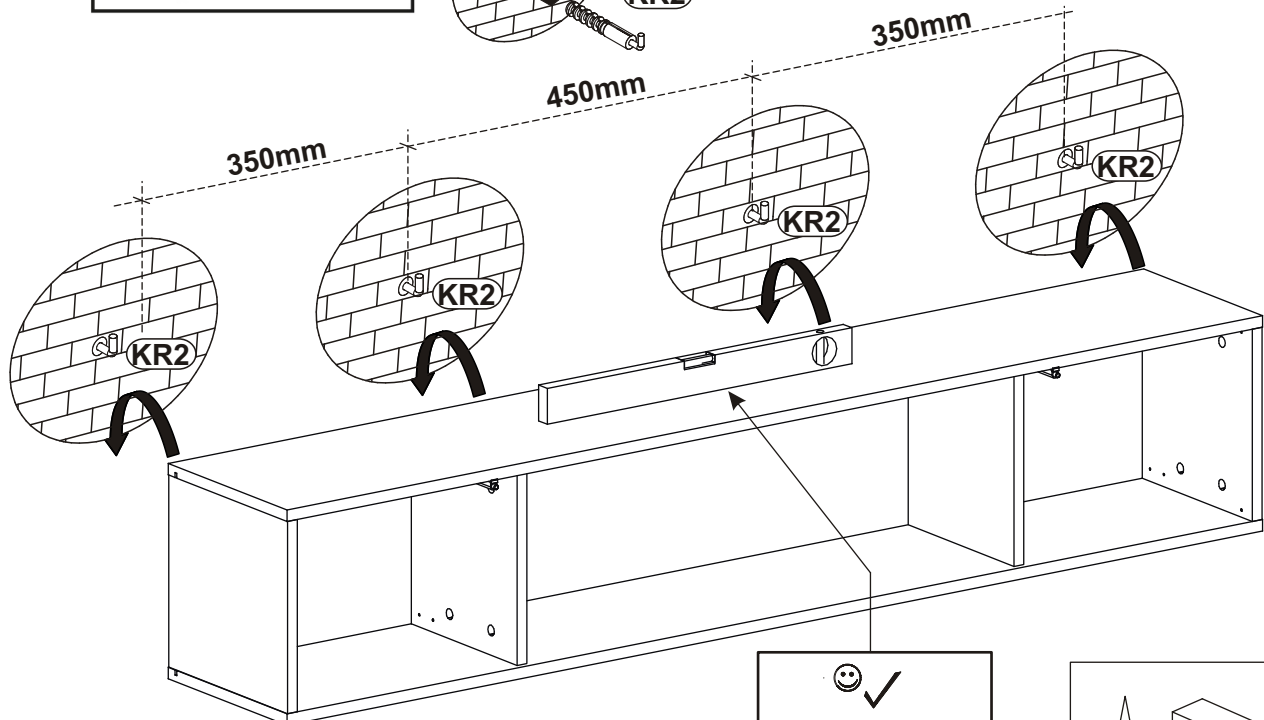
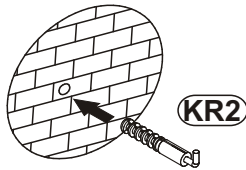
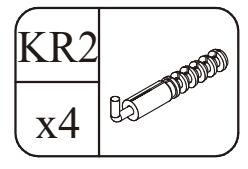
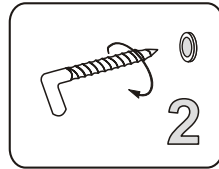
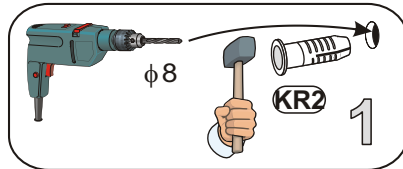
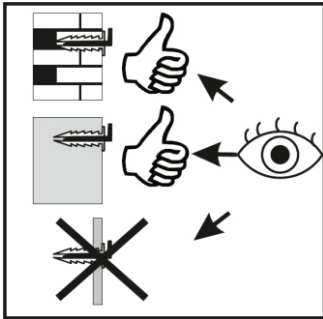

9

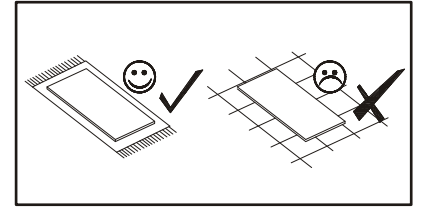
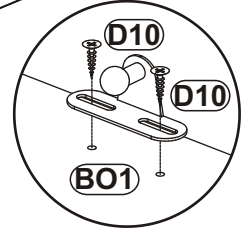
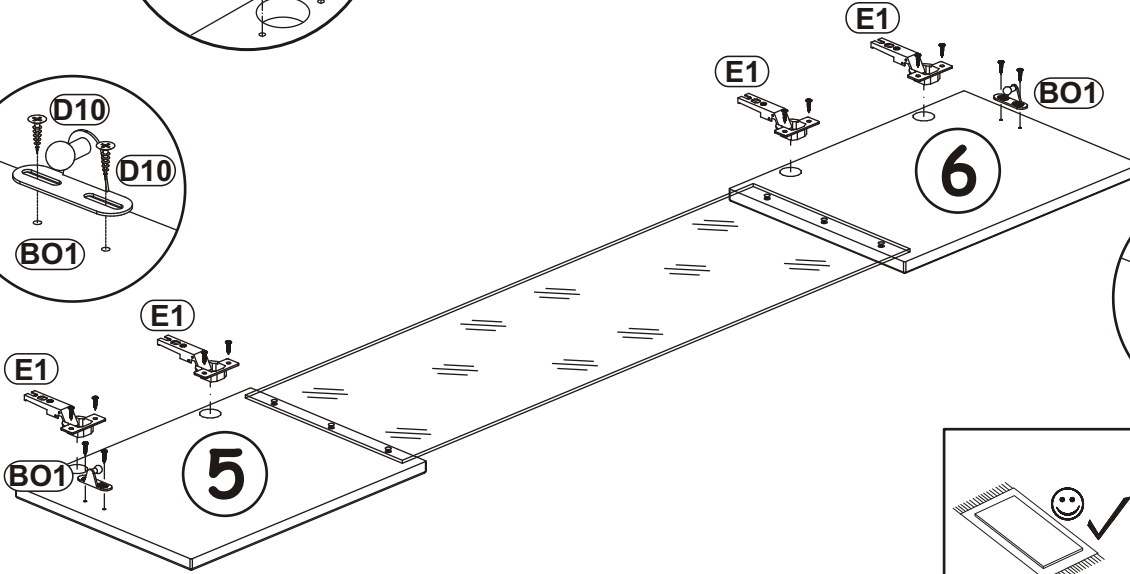
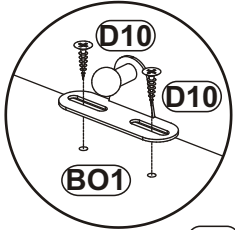
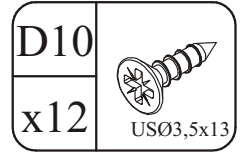
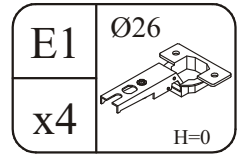
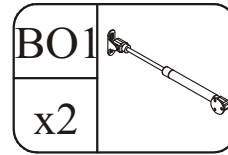
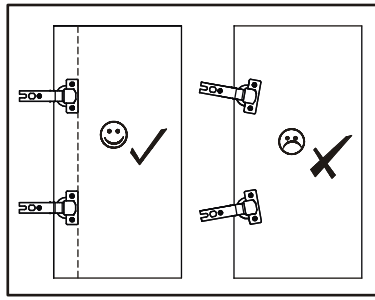
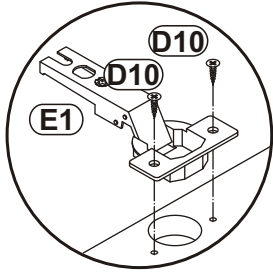

10

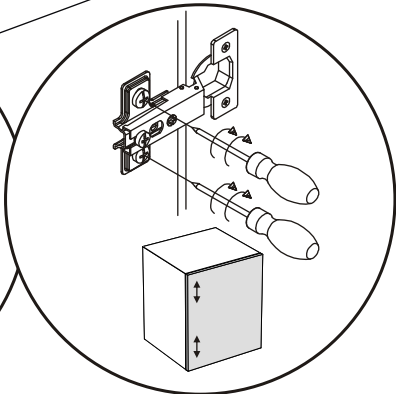
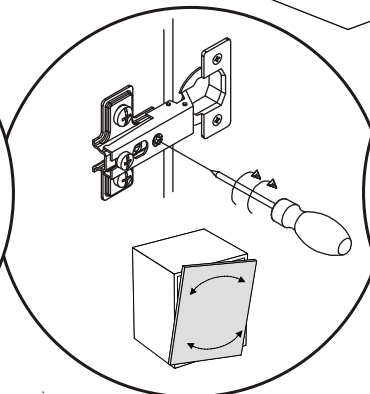
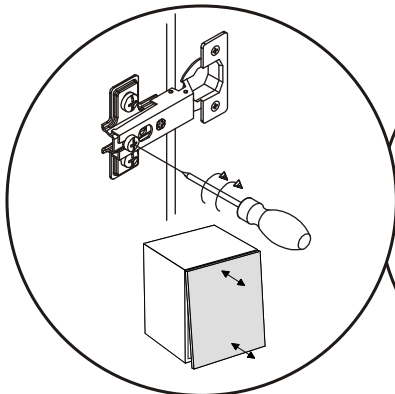
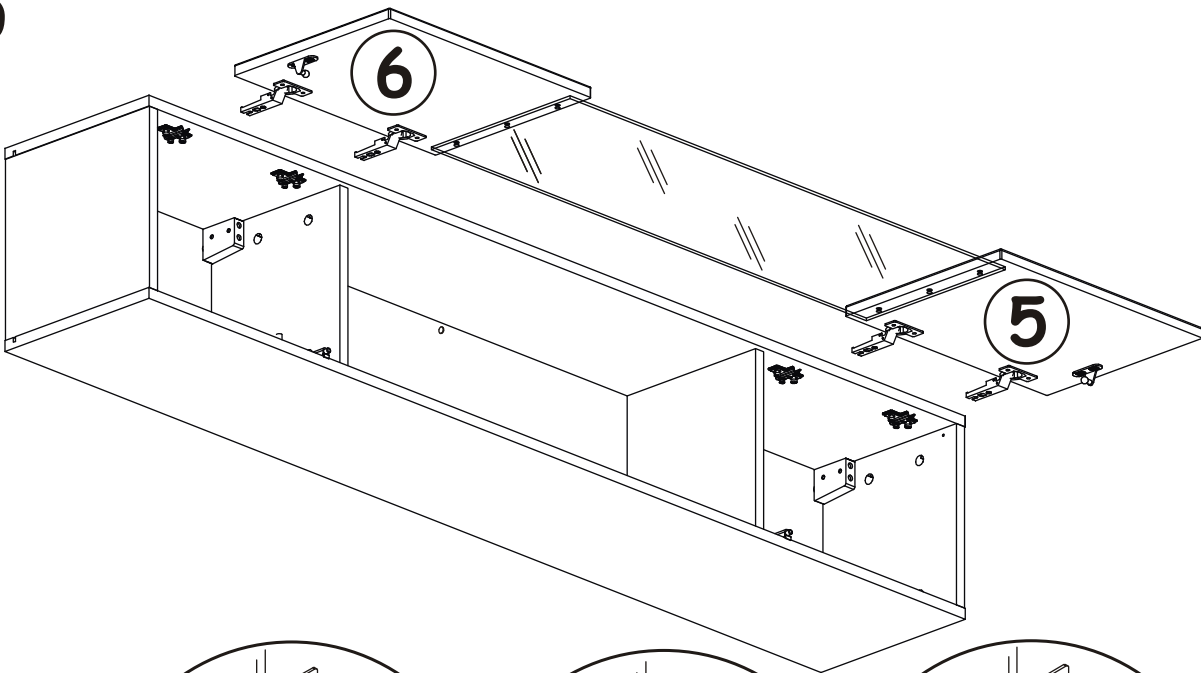

11

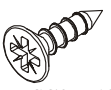
D10	
x6	USØ3,5x13

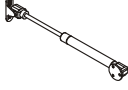
B01	
x2	

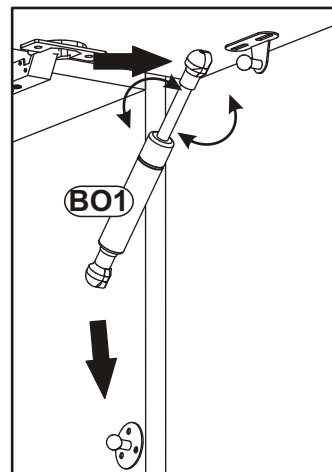
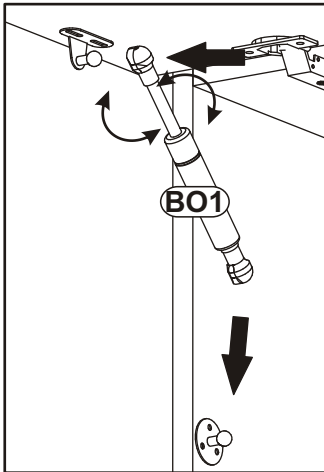
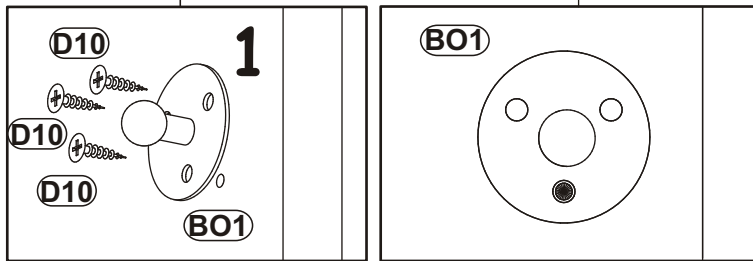
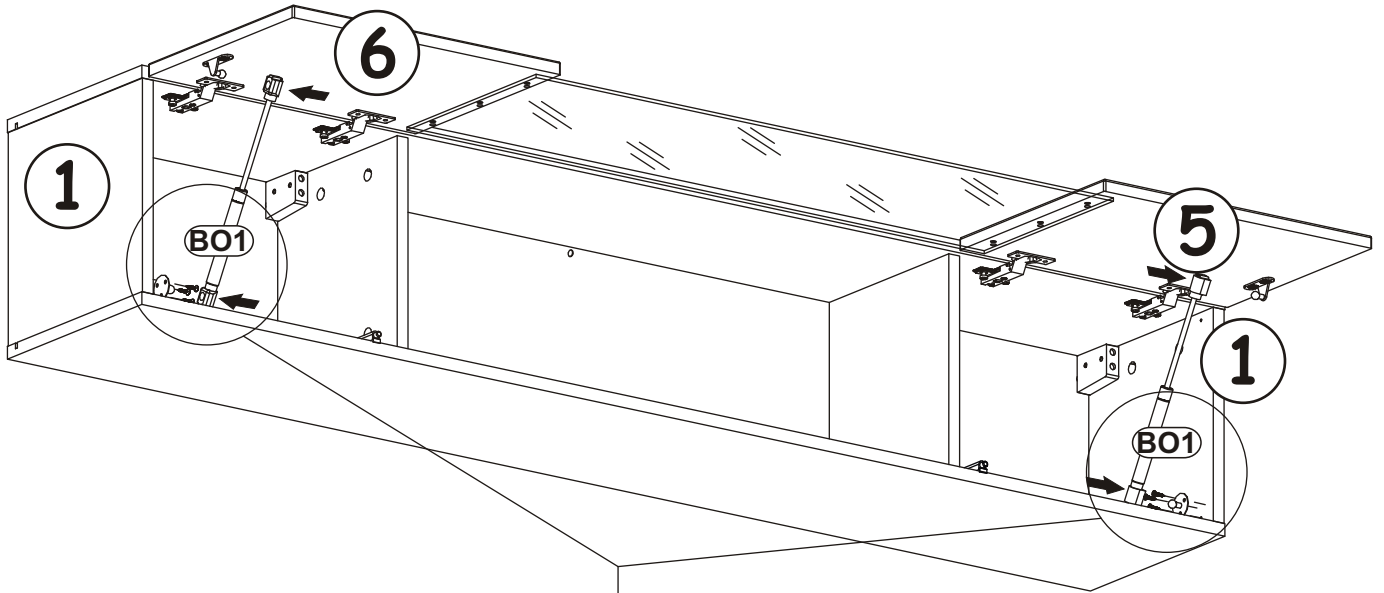



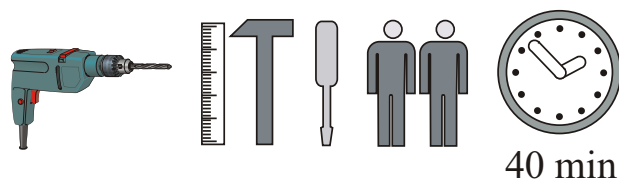
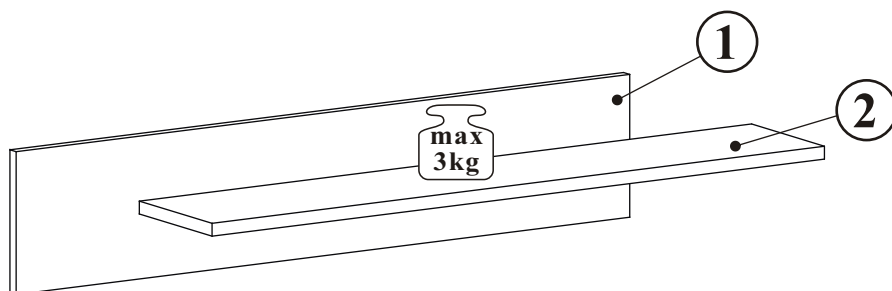
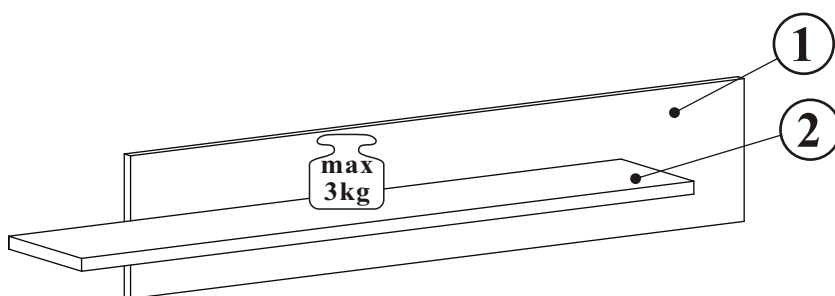
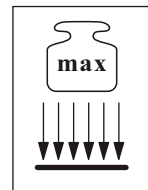
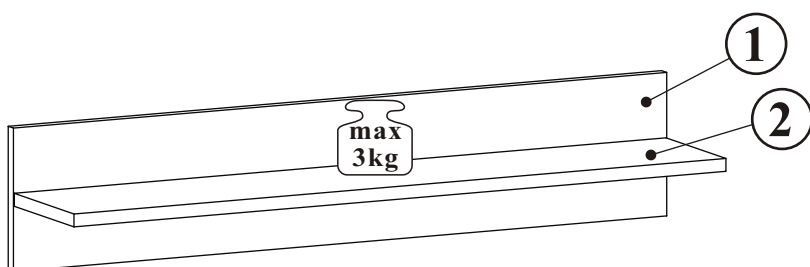



GALINO 23_MX

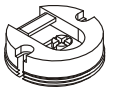

NO	Dim.		Col.-No	Qty
1	1002	200	1	2
2	1000	185	1	2

GALINO 23_MX

ZM1 x4		D20 x8	 ESØ6x9,5	B11 x12	 Ø7x50	G4 x12		KR2 x4		G2 x1	
-----------	---	-----------	---	------------	--	-----------	---	-----------	---	----------	---

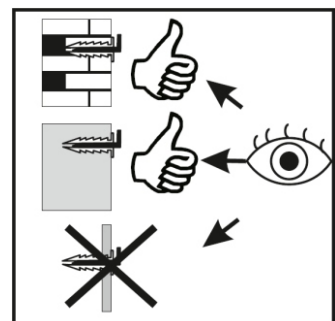
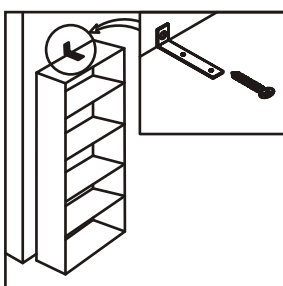
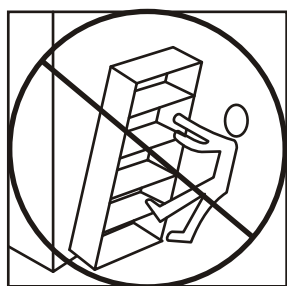
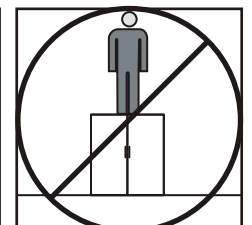
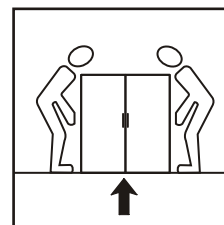
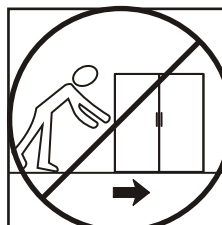
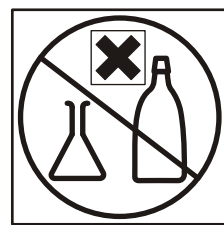
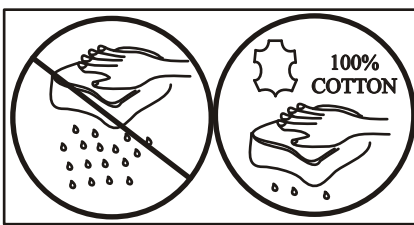
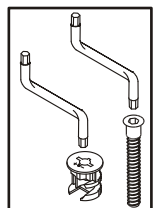
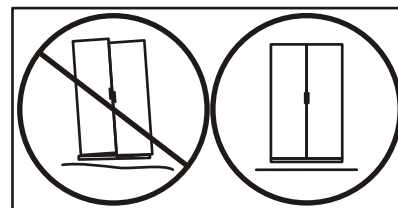
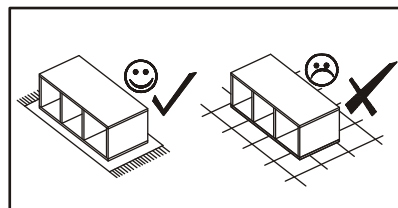
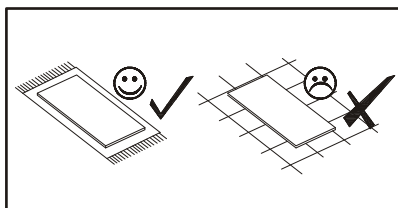
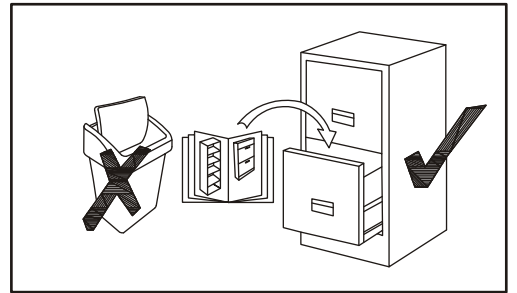
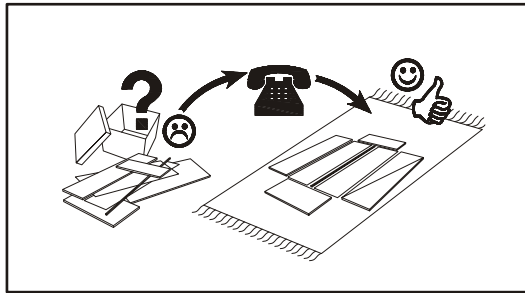
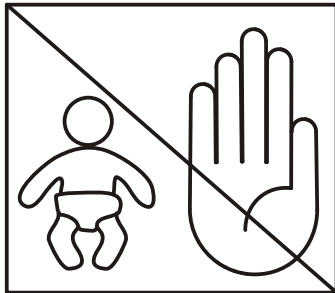
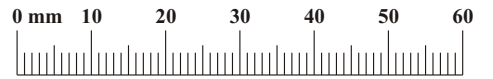

1-3

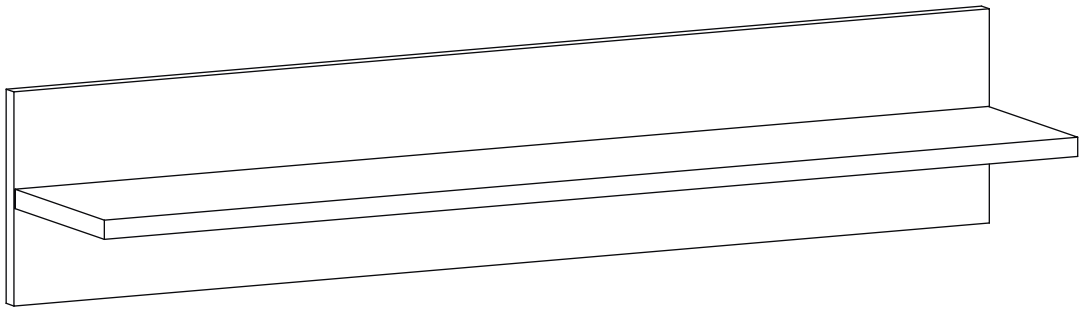

4-6

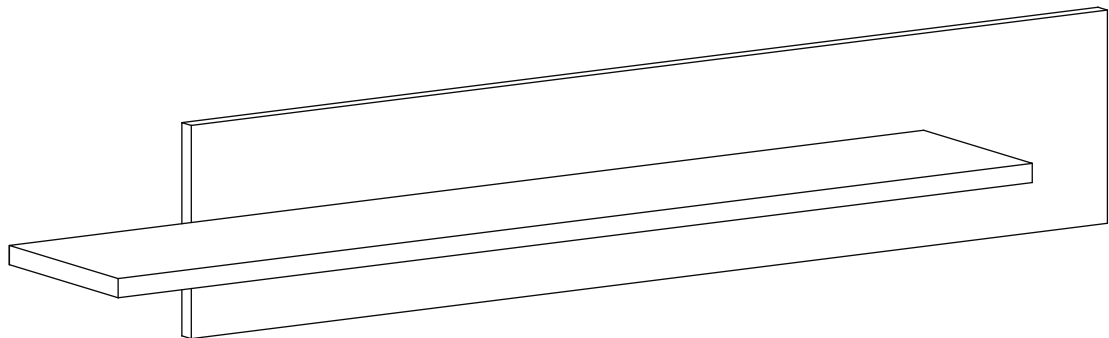

7-9

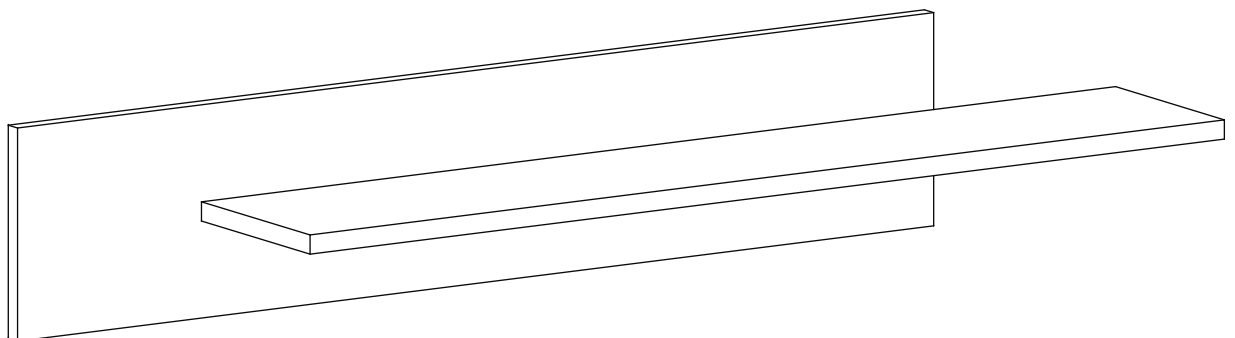

GALINO 23_MX

1

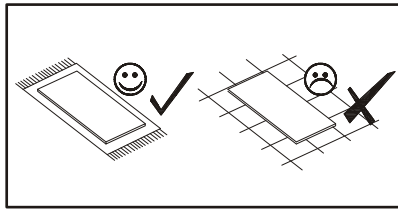

ZM1
x4

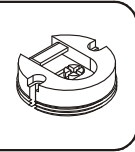

D20
x8

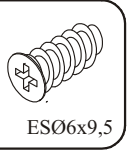

ESØ6x9,5

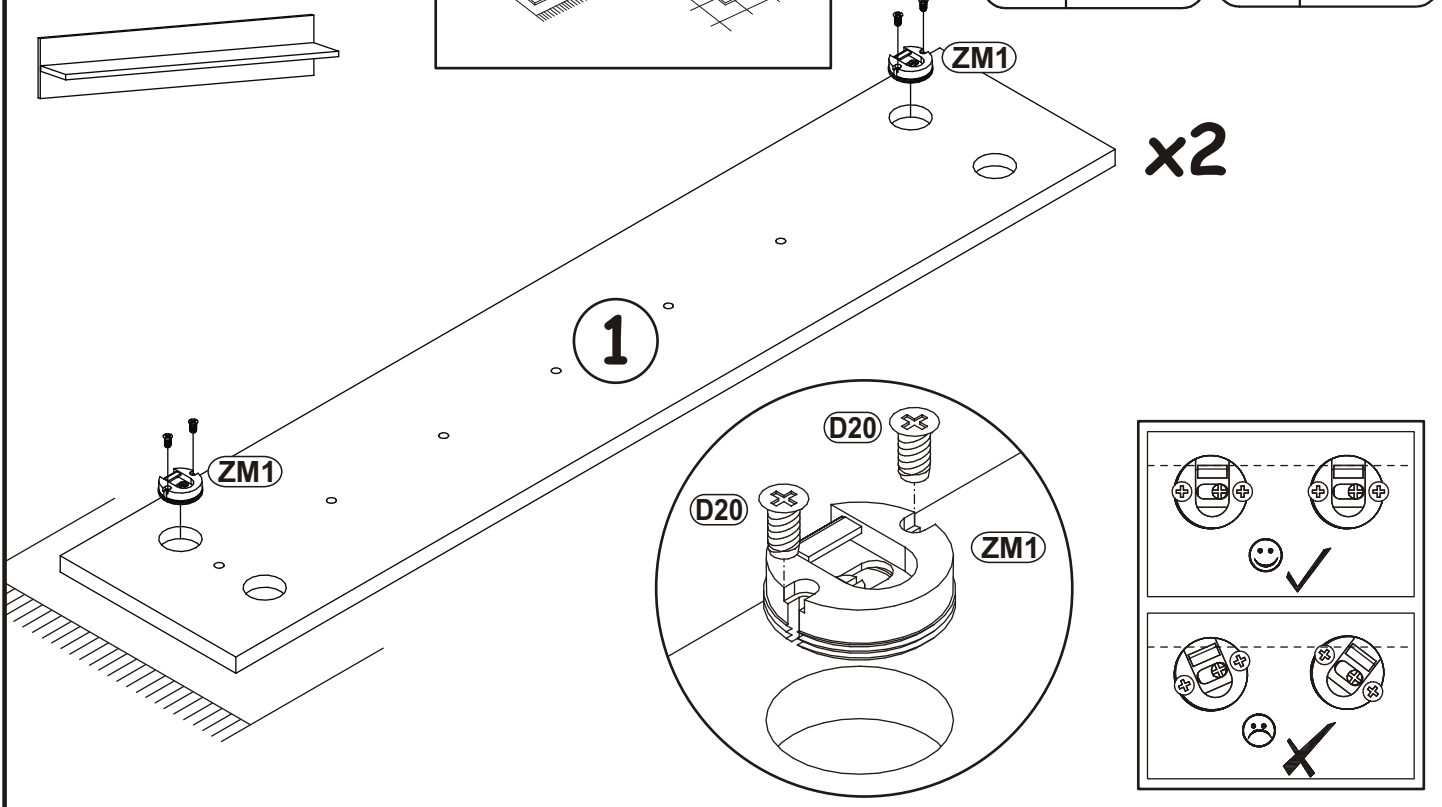

2

B11
x12

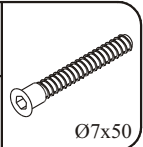

Ø7x50

G4
x12

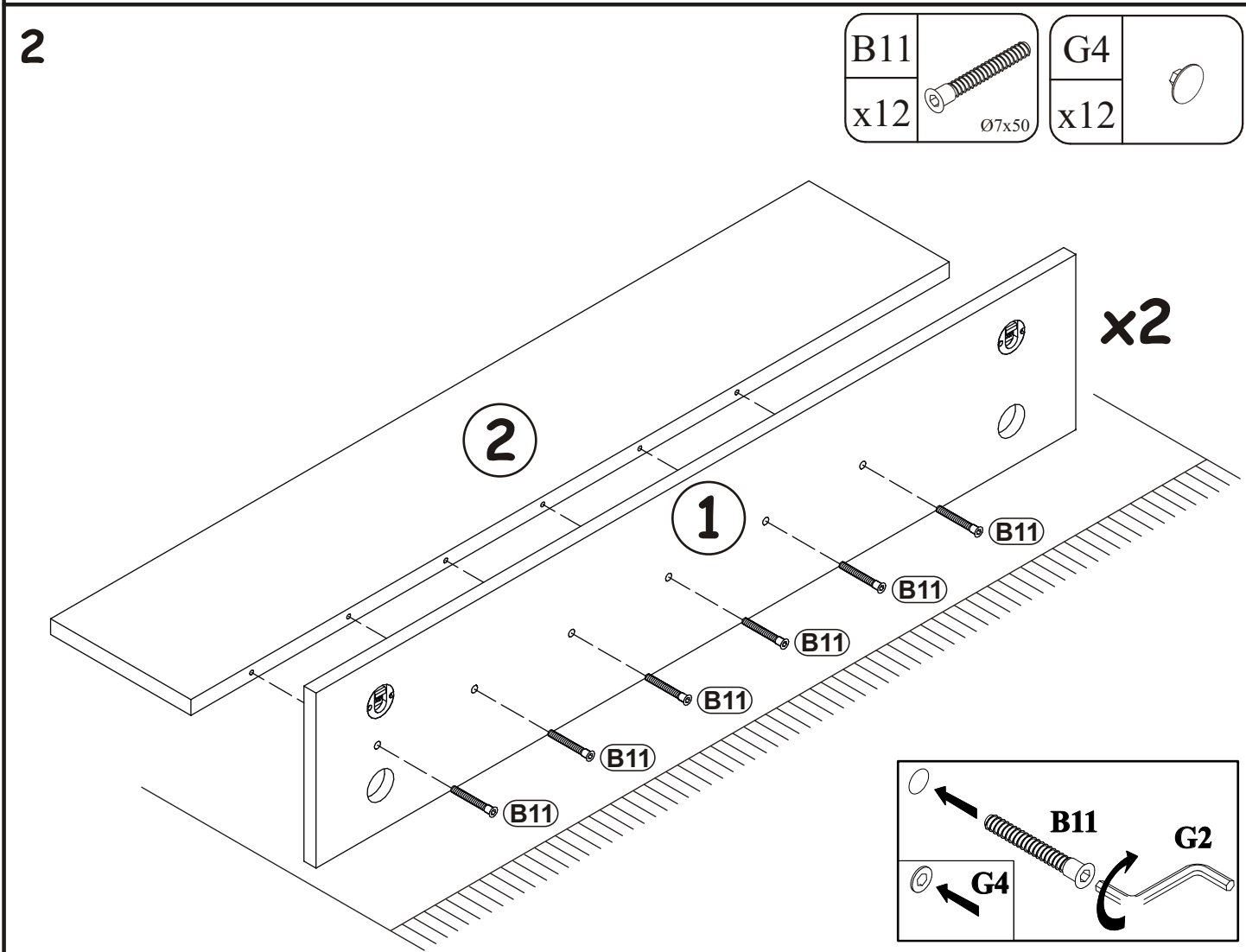
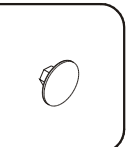

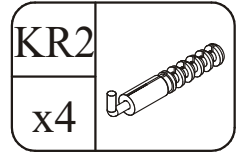

3

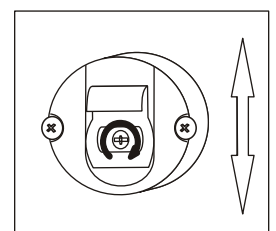
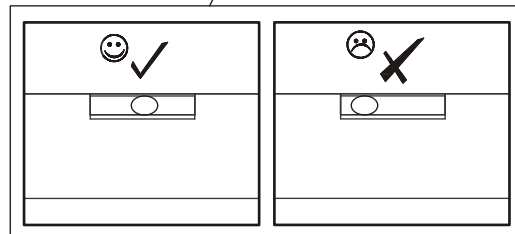
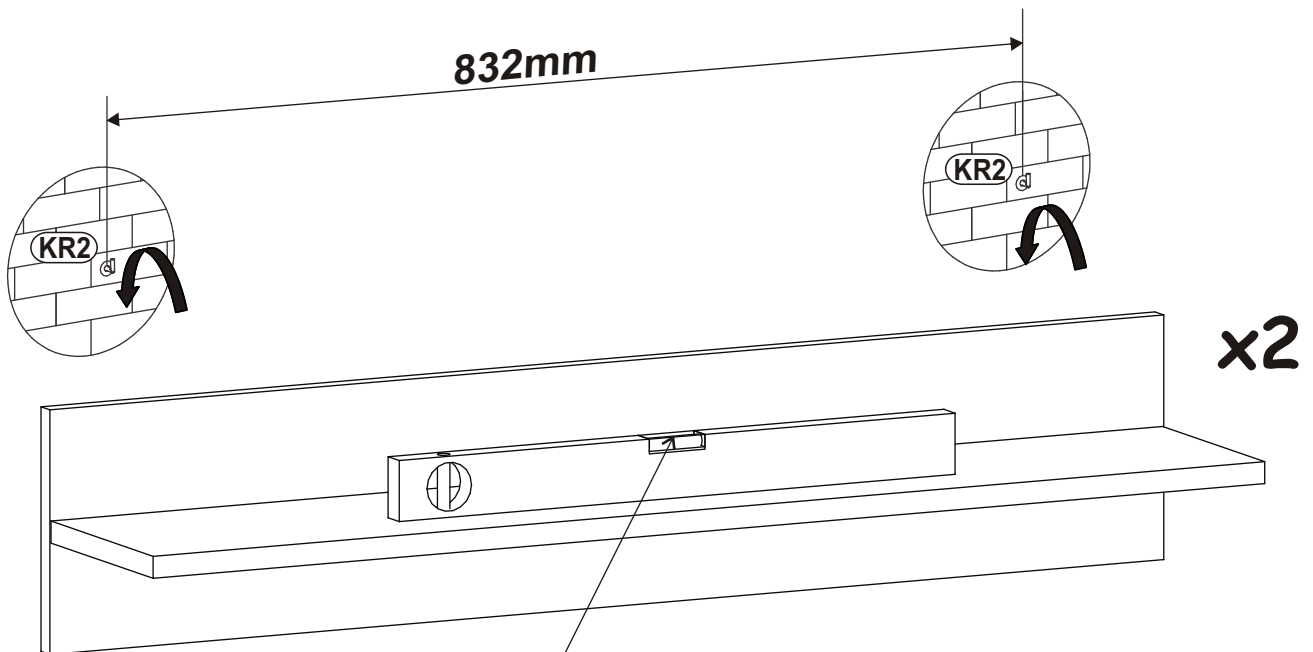
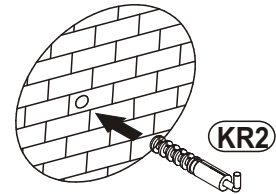
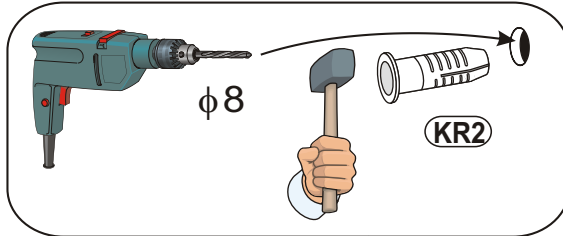
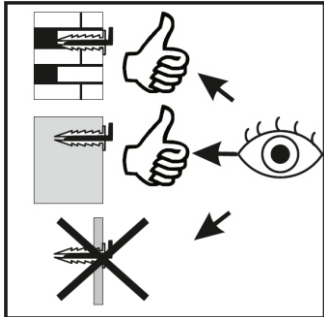

4

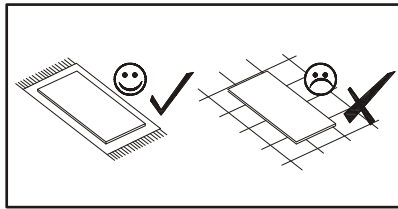

ZM1		D20	
x4		x8	ESØ6x9,5

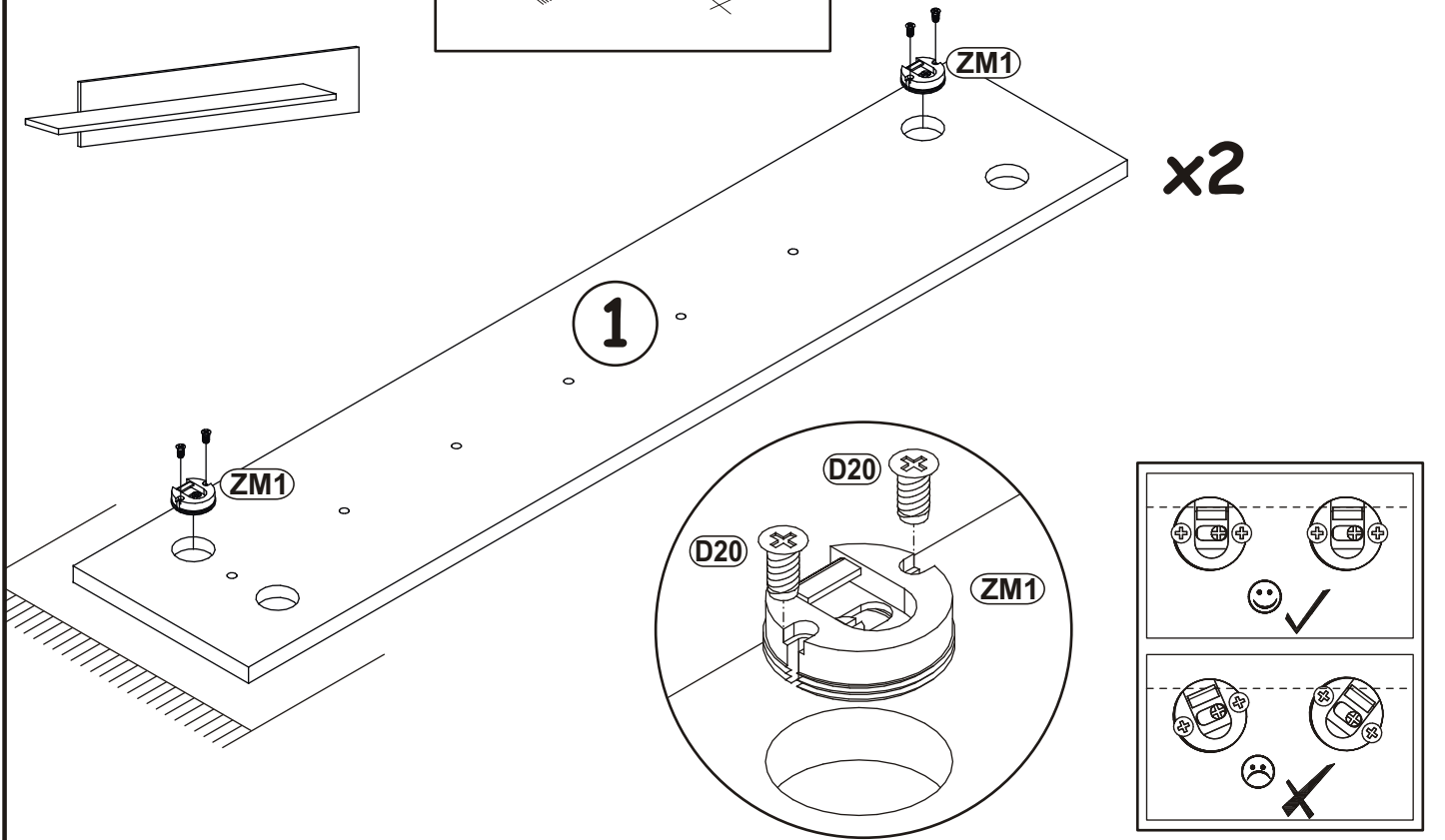

5

B11		G4	
x12	Ø7x50	x12	

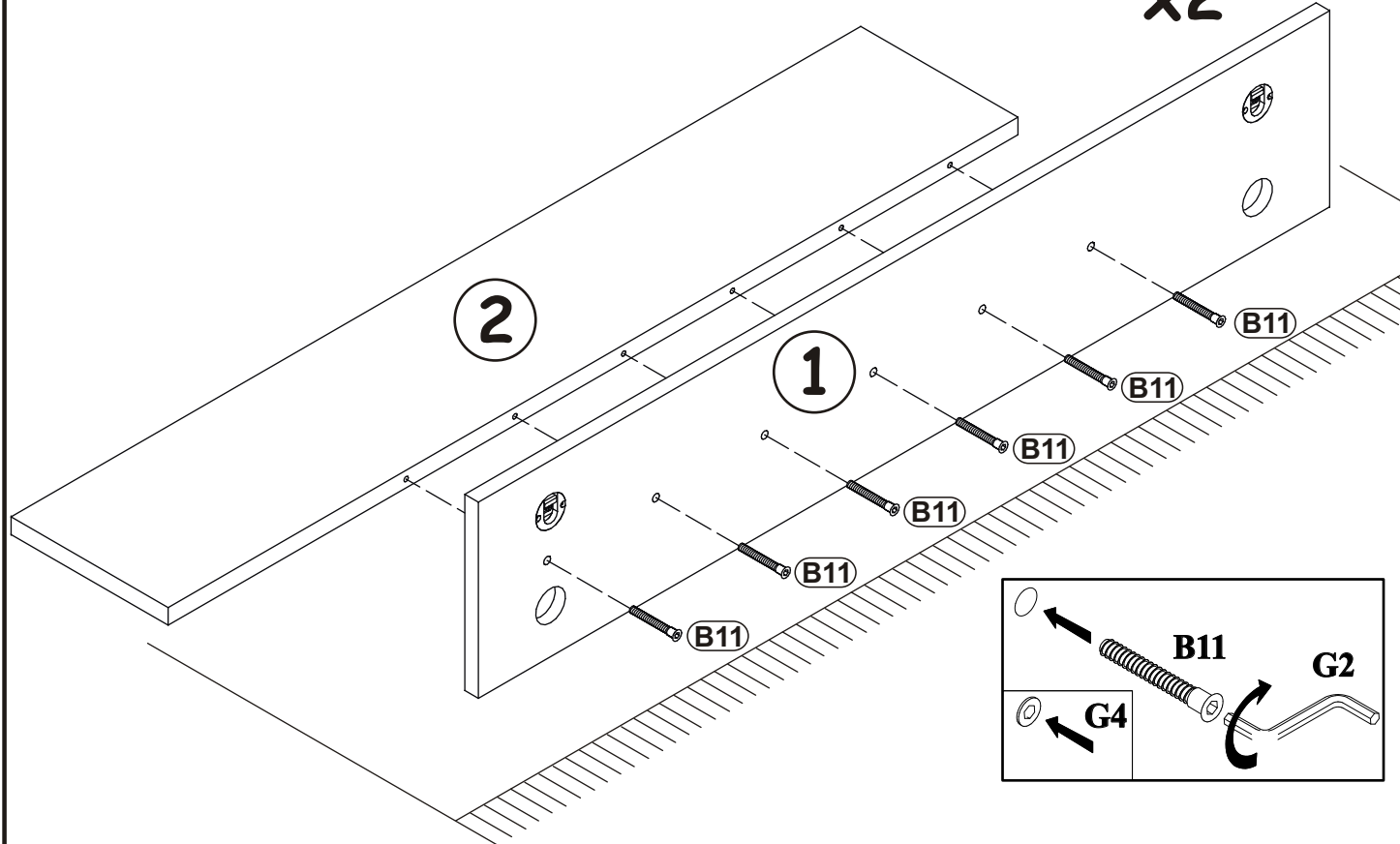

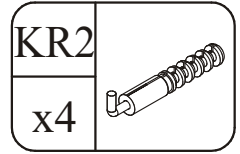

6

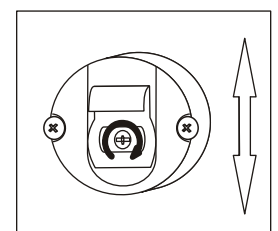
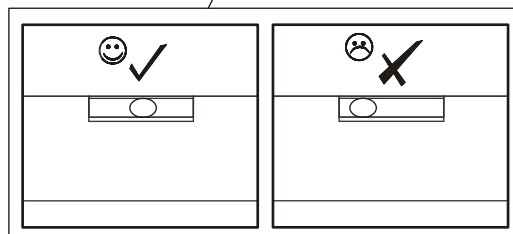
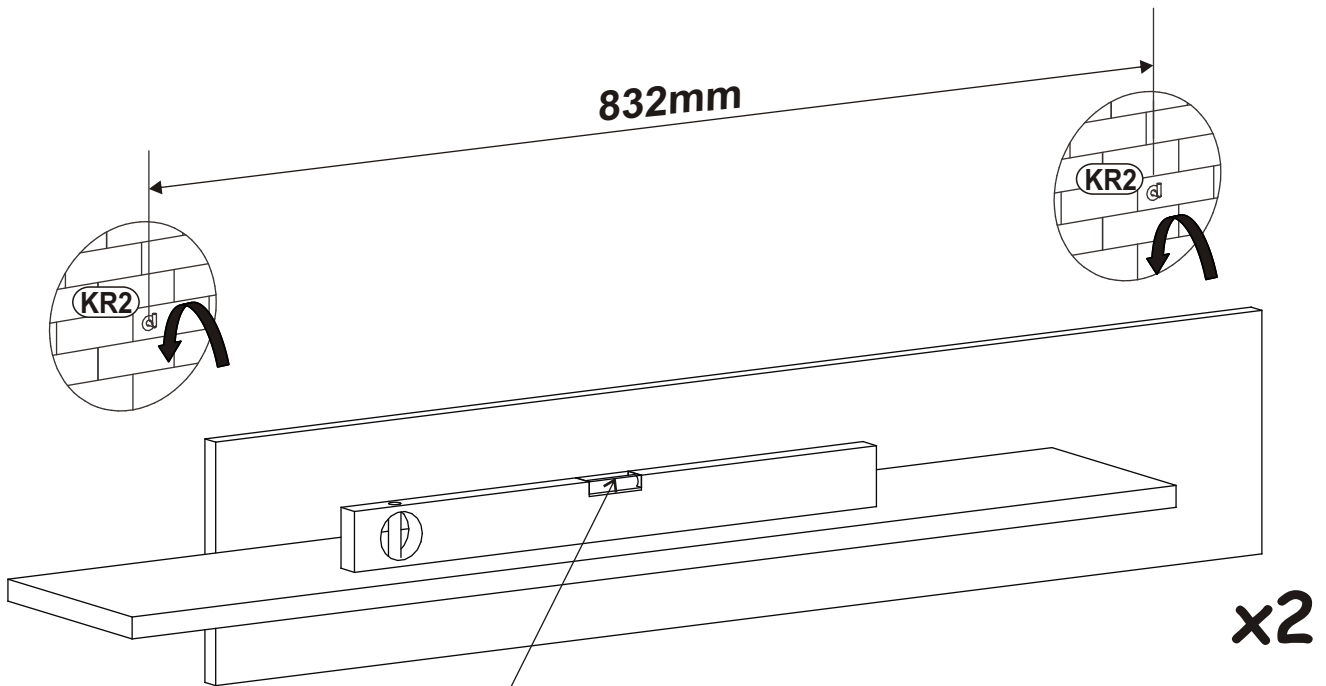
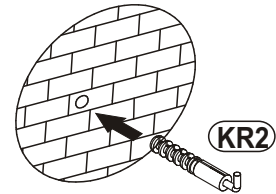
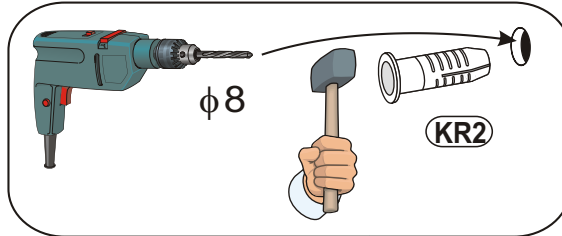
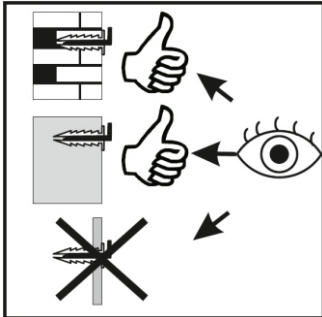

7

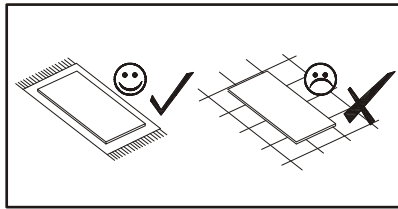

ZM1		D20	
x4		x8	

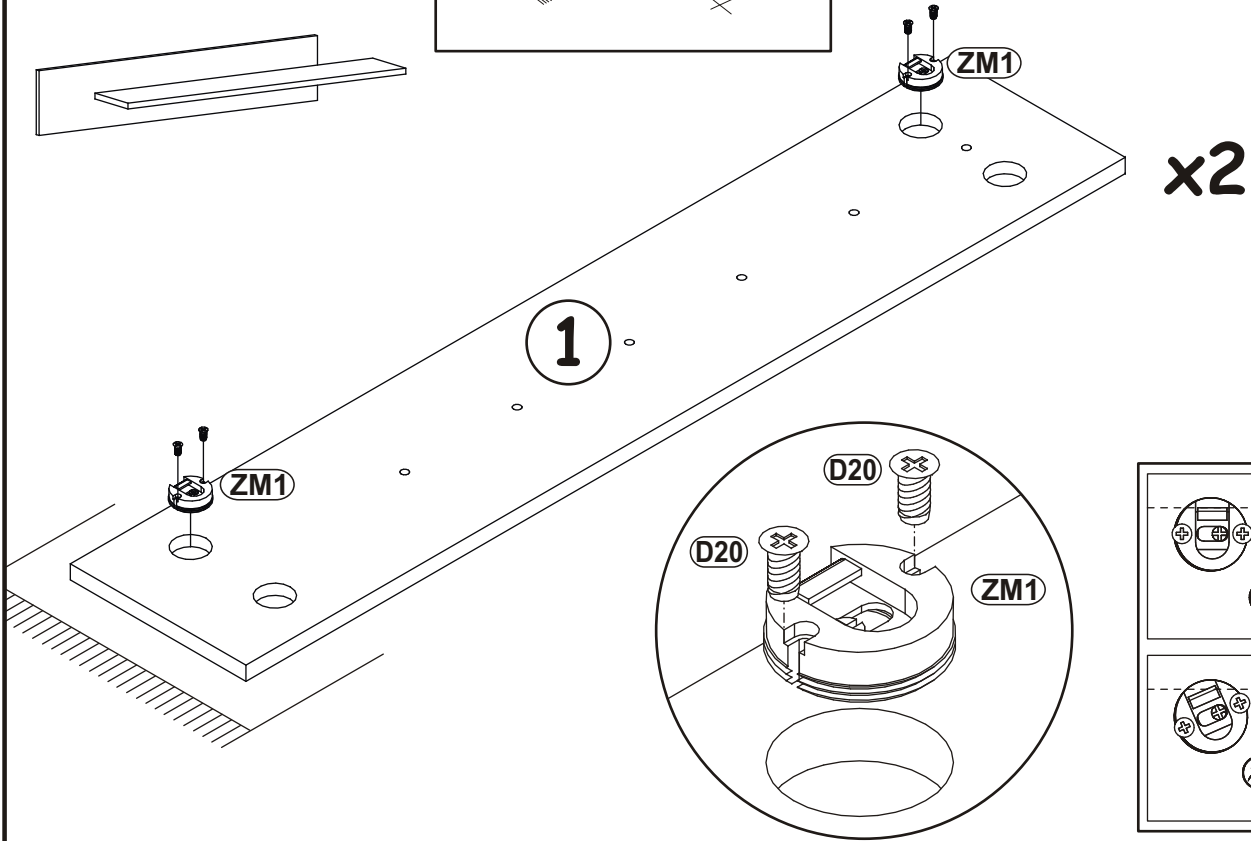

8

B11		G4	
x12	Ø7x50	x12	

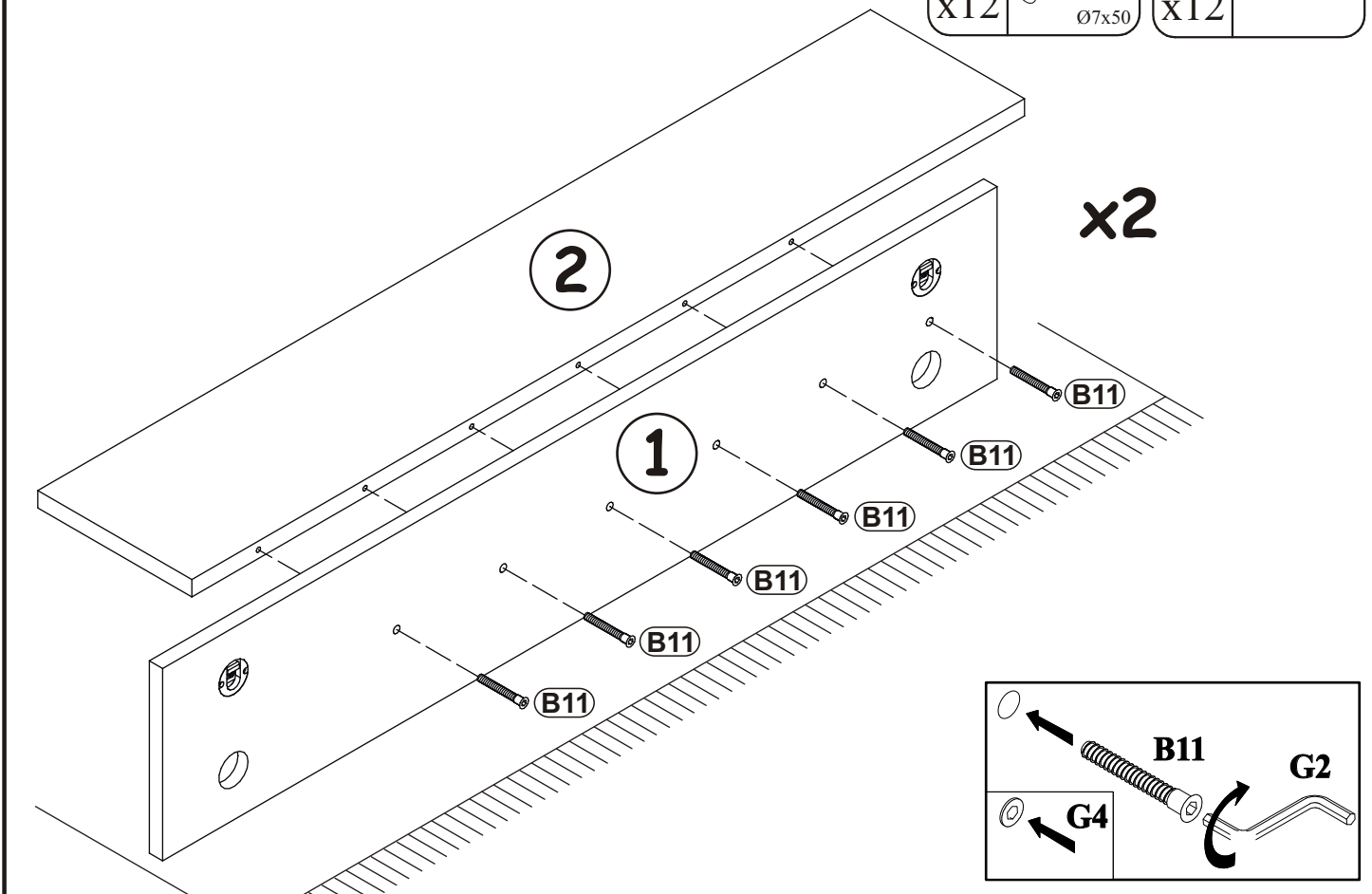

9

