

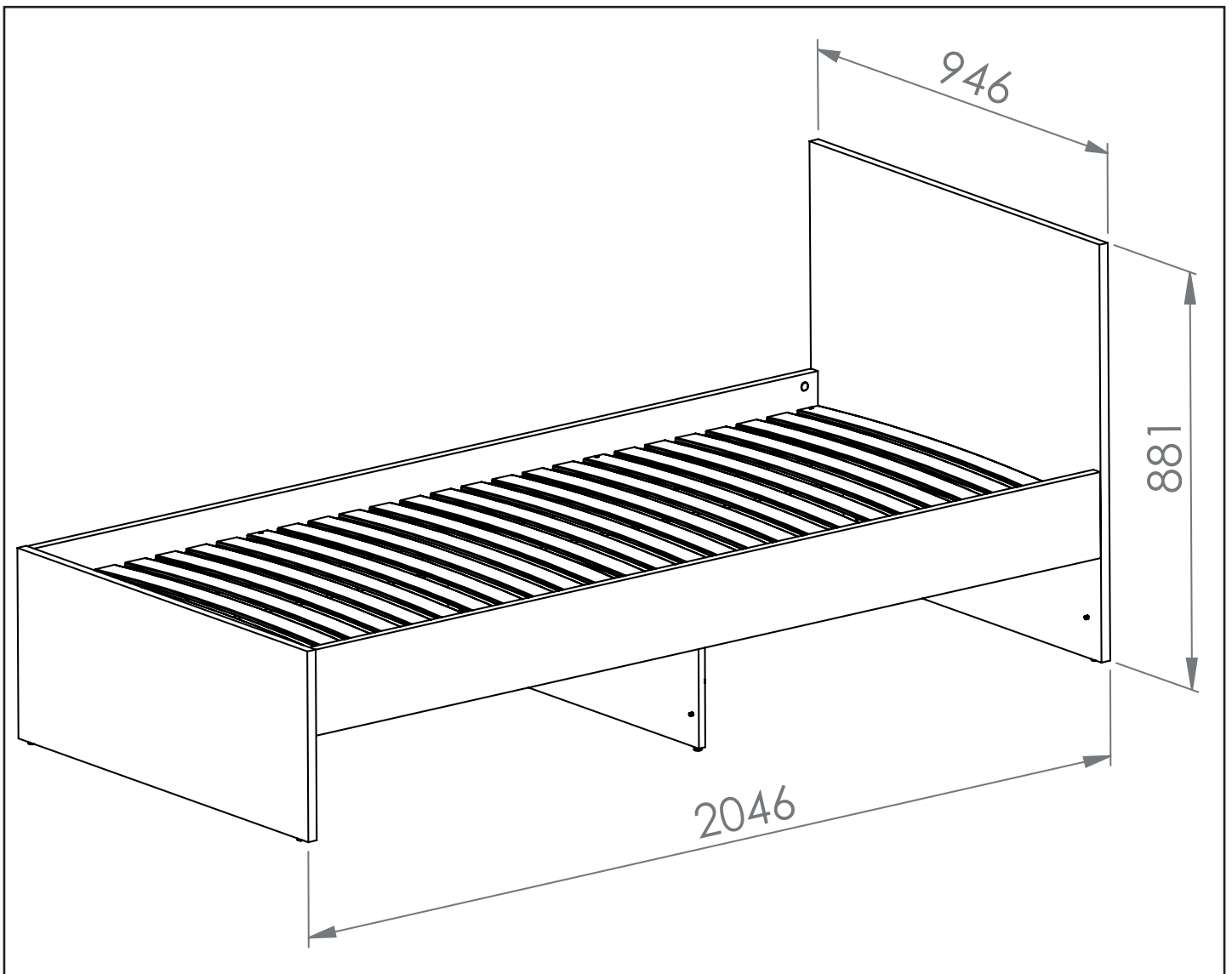

# ELMO 14

PL - Instrukcja montażu / BG - Сглобяване инструкция / CZ - Montáž instrukce / DE - Montageanleitung / EN - Assembling instruction / ES - Montaje de instrucción / EST - Paigaldusjuhend / FR - Notice de montage / HR - Sastavljanje upute / HU - Szerelési utasítás / I - Istruzioni di montaggio / LT - Montavimo instrukcija / LV - Montāžas instrukcija / NL - Montage instructie / P - Montagem de instrução / RO - Asamblarea de instrucțiuni / RU - Инструкция сборки / S - Montering instruktion / SK - Montáž inštrukcie / SLO - Sestavljanje navodila / SRB - Skлапање инструкции / TR - Kurulum Talimatları / UKR - Збірка інструкція /

PL - Przed rozpoczęciem zapoznać się z instrukcją montażu / BG - Преди да започнете се отнасят към инструкциите за инсталиране / CZ - Před zahájením naleznete v montážním návodu / DE - Vor die montage, bitte beiliegende anweisungen folgen / EN - Before starting, refer to the assembling advice in annex / ES - Antes de comenzar referirse a las instrucciones de instalación / EST - Enne käivitamist vaadake paigaldusjuhiseid / FR - Avant de commencer, se reporter aux conseils de montage en annexe / HR - Prije početka pogledajte upute za instalaciju / HU - Megkezdése előtt olvassa el a telepítési utasításokat / I - Avanti di cominciare, riportate agli consigli di montaggio / LT - Prieš pradant kreiptis į montavimo instrukcija / LV - Pirms sākt montāžu, iepazīties ar instrukciju / NL - Voordat u begint Zie de installatie-instructies / P - Antes de começar a consultar as instruções de instalação / RO - Înainte de a începe să consultați instrucțiunile de instalare / RU - Перед началом обратитесь к инструкции по установке / S - Innan du börjar se Installationsanvisningen / SK - Pred začatím nájdete v montážnom návode / SLO - Pred začetkom glejte navodila za nameštitev / SRB - Пре почетка погледајте упутства за инсталацију / TR - Kurulumla başlanmadan önce, montaj talimatnamesini sırasıyla takip edin. / UKR - Перед початком зверніться до інструкції з установки /

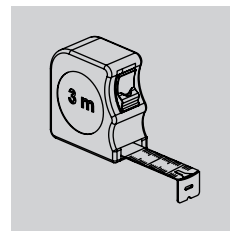
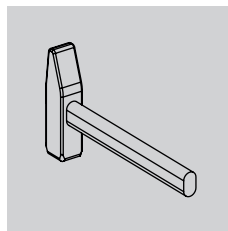
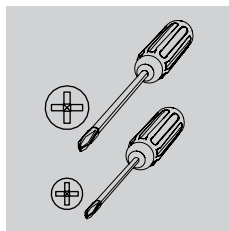
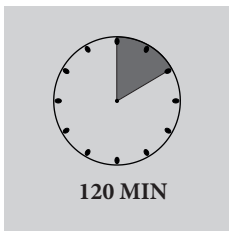

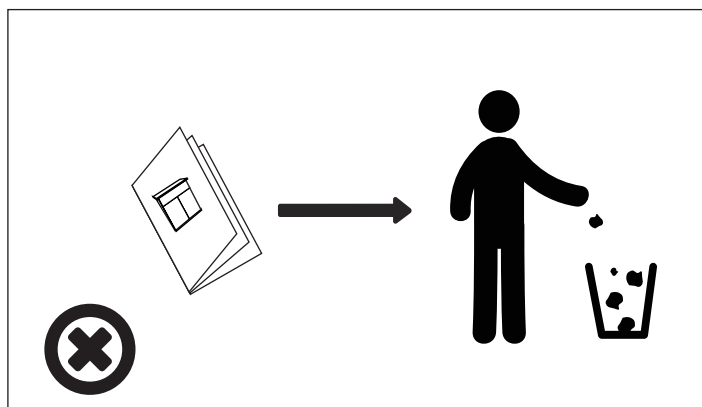
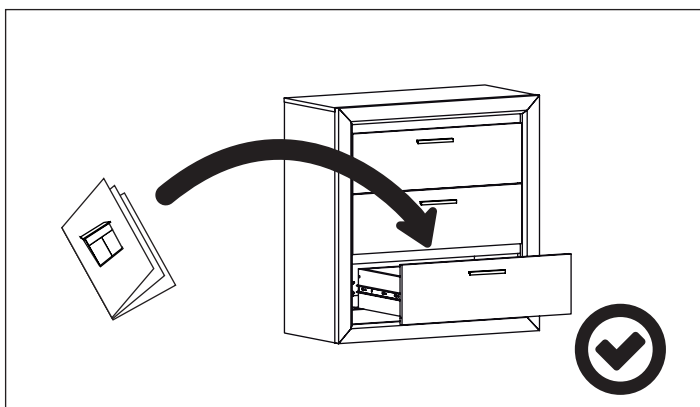
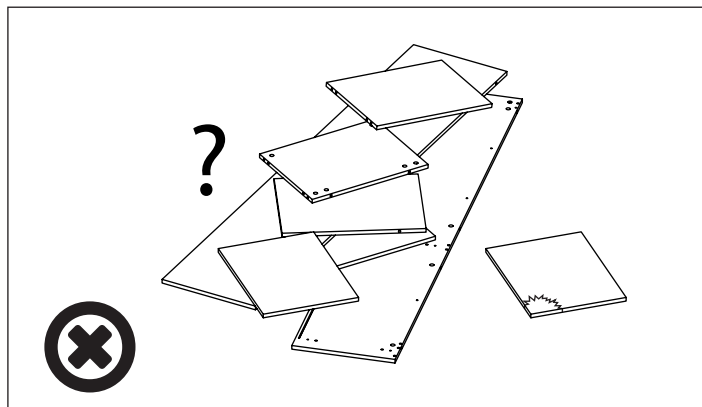
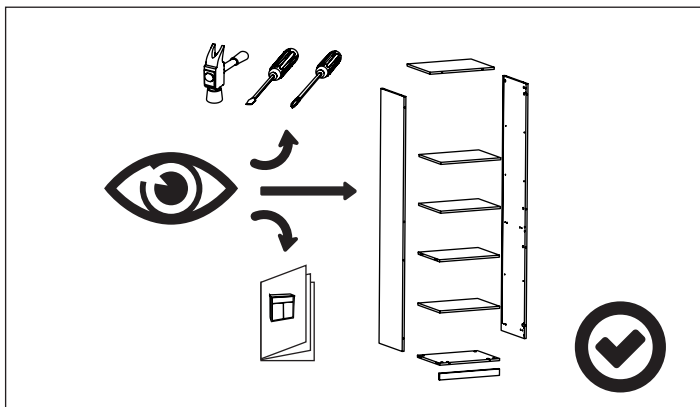
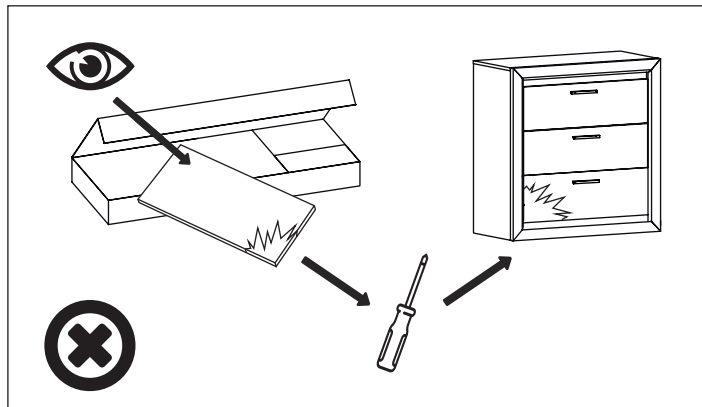
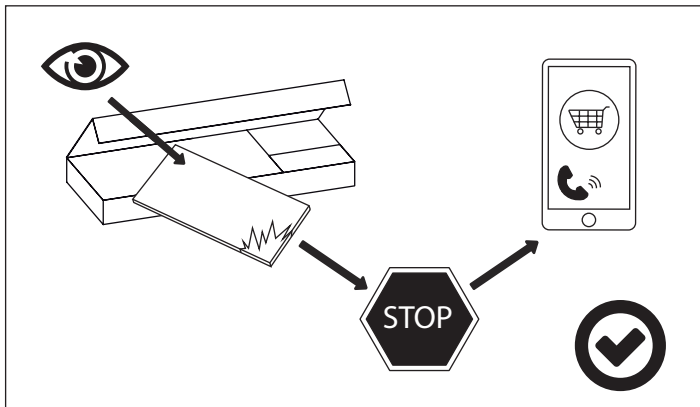
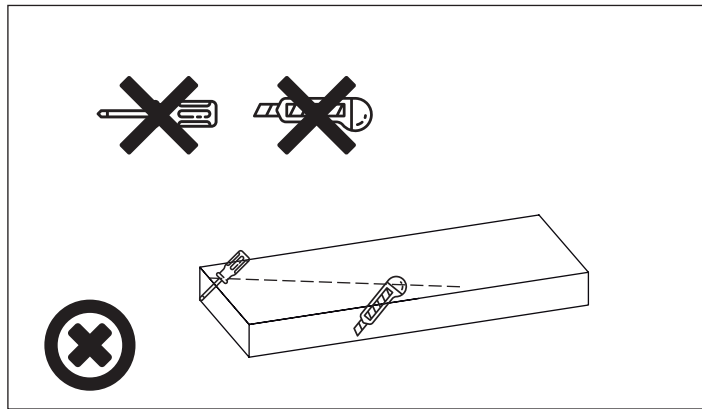
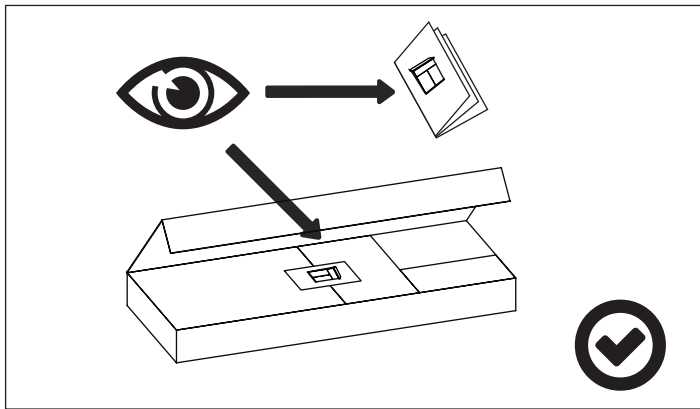

	CODE				
1	Elmo14_01	946	876	1	2/2
2	Elmo14_06	900	80	2	1/2
3	WKL-90-002	2000	900	1	1/1
4	Elmo14_02	946	400	1	2/2
5	Elmo14_03	2002	180	2	1/2
6	Elmo14_07	50	998	4	1/2
7	Elmo14_05	900	124	1	2/2
8	Elmo14_04	900	245	1	2/2
9					
10					
11					
12					
13					
14					
15					

	CODE				
16					
17					
18					
19					
20					
21					
22					
23					
24					
25					
26					
27					
28					
29					
30					

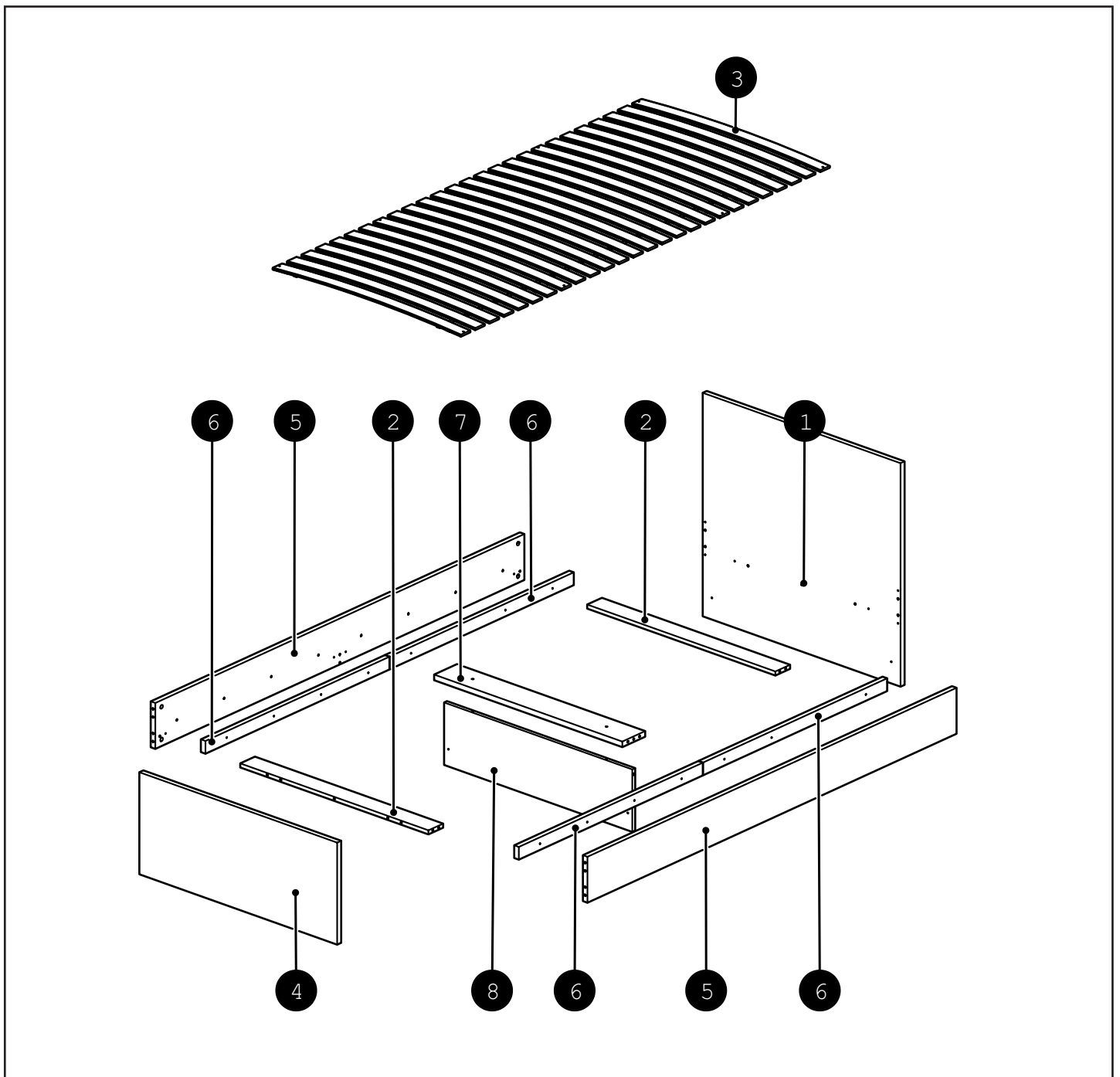

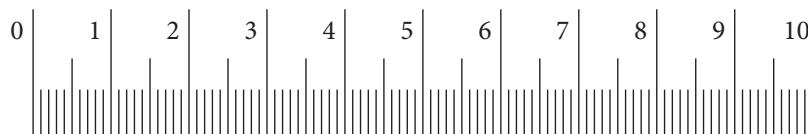
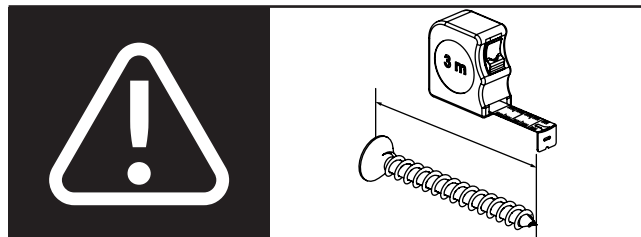
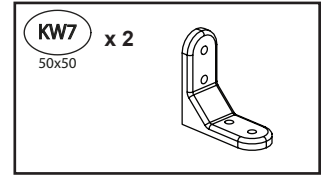
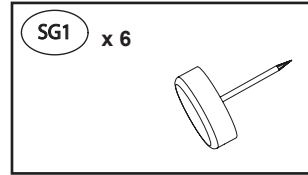
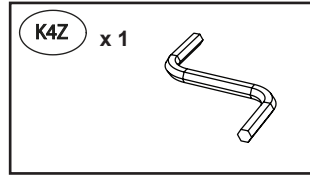
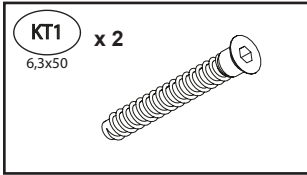
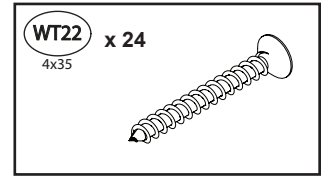
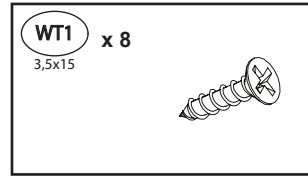
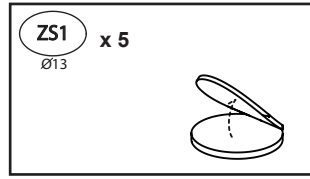
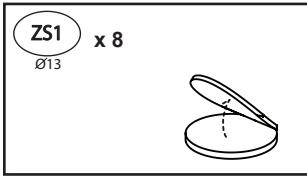
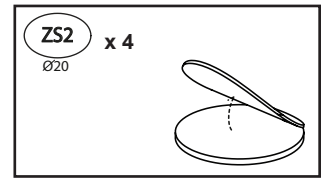
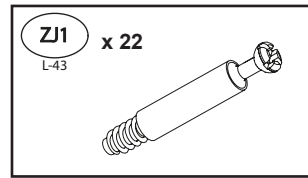
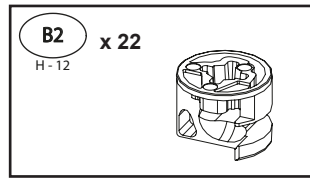
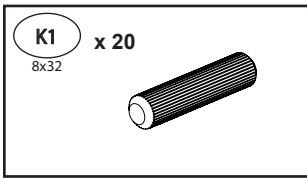

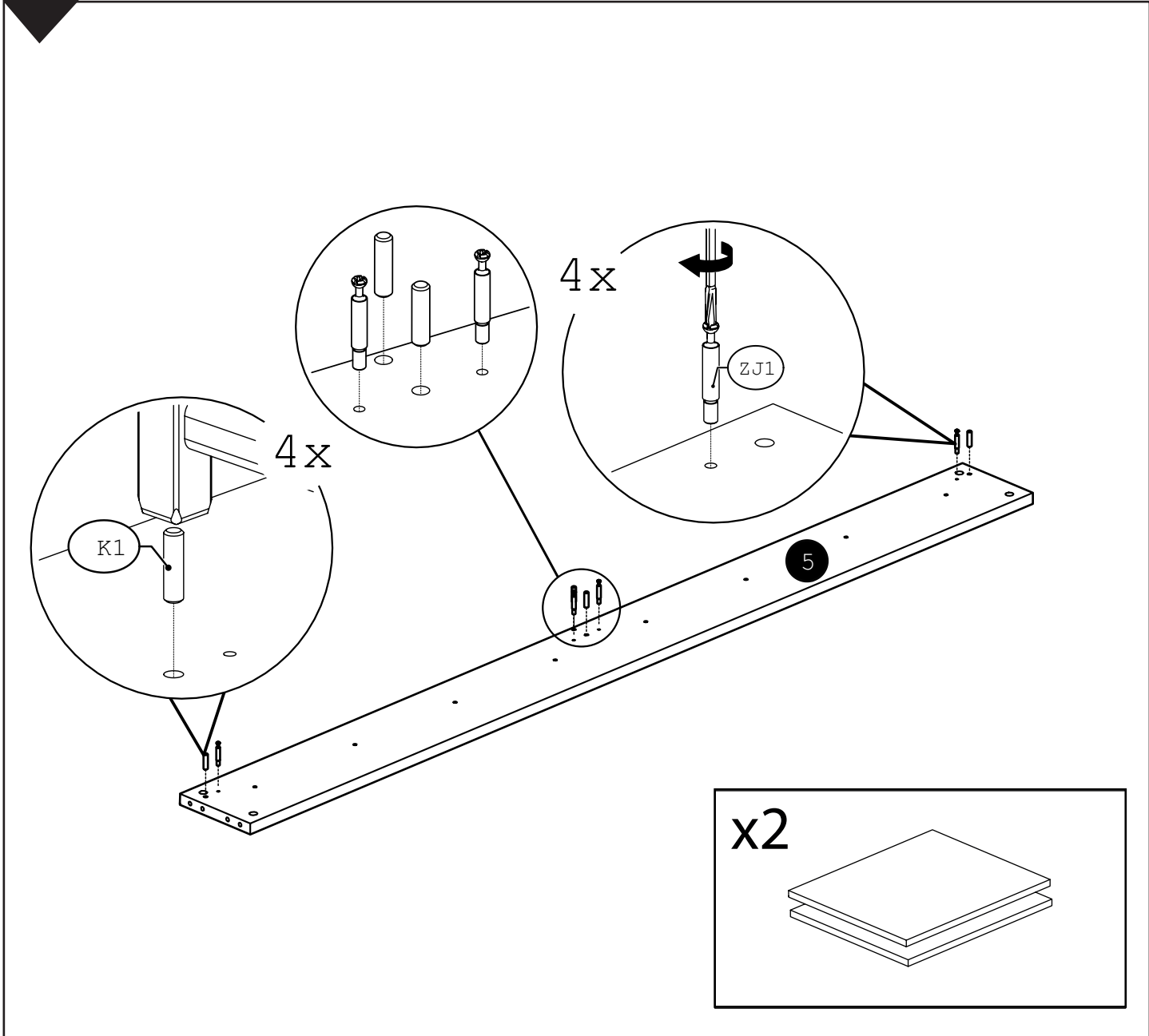
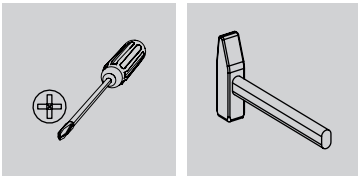
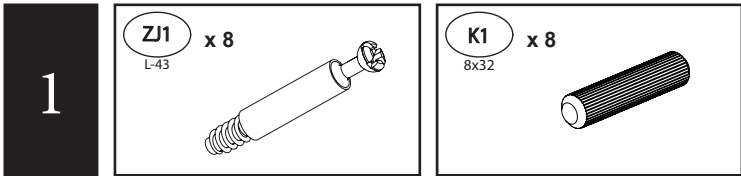
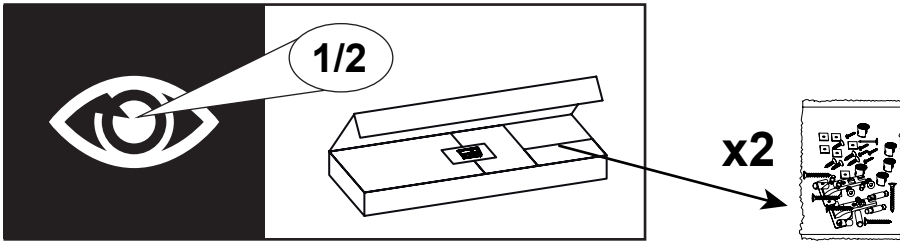
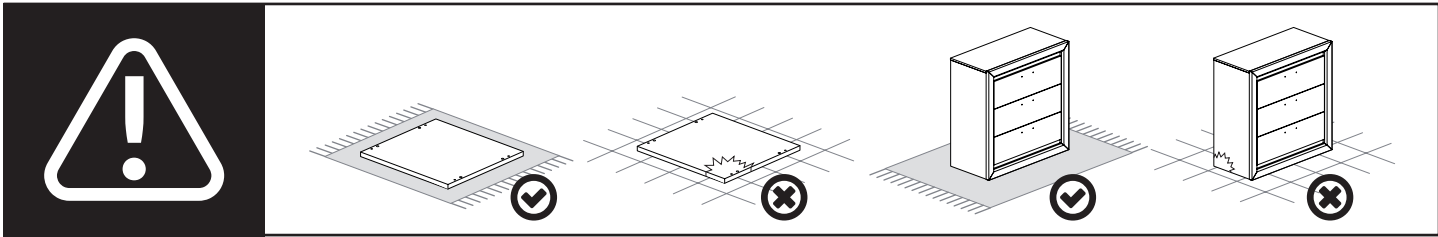

2

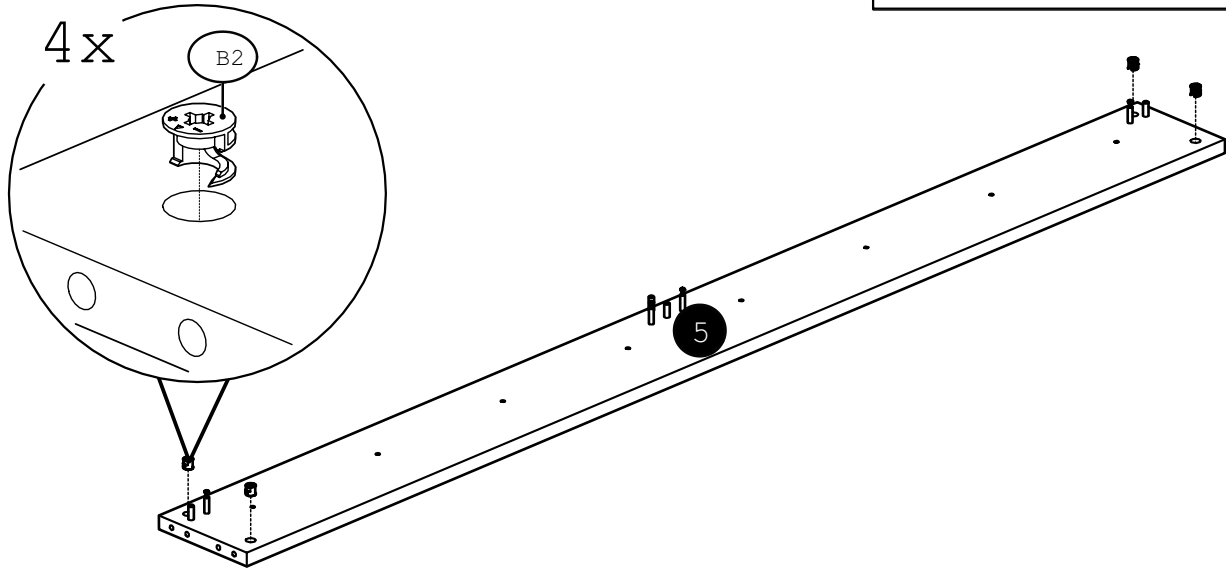
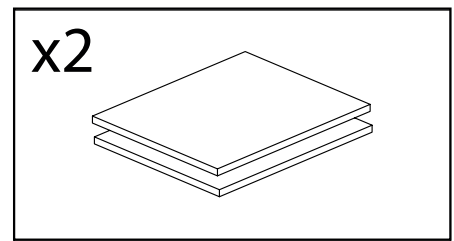
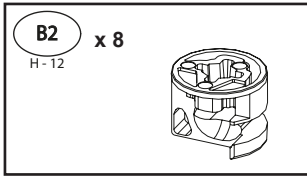

3

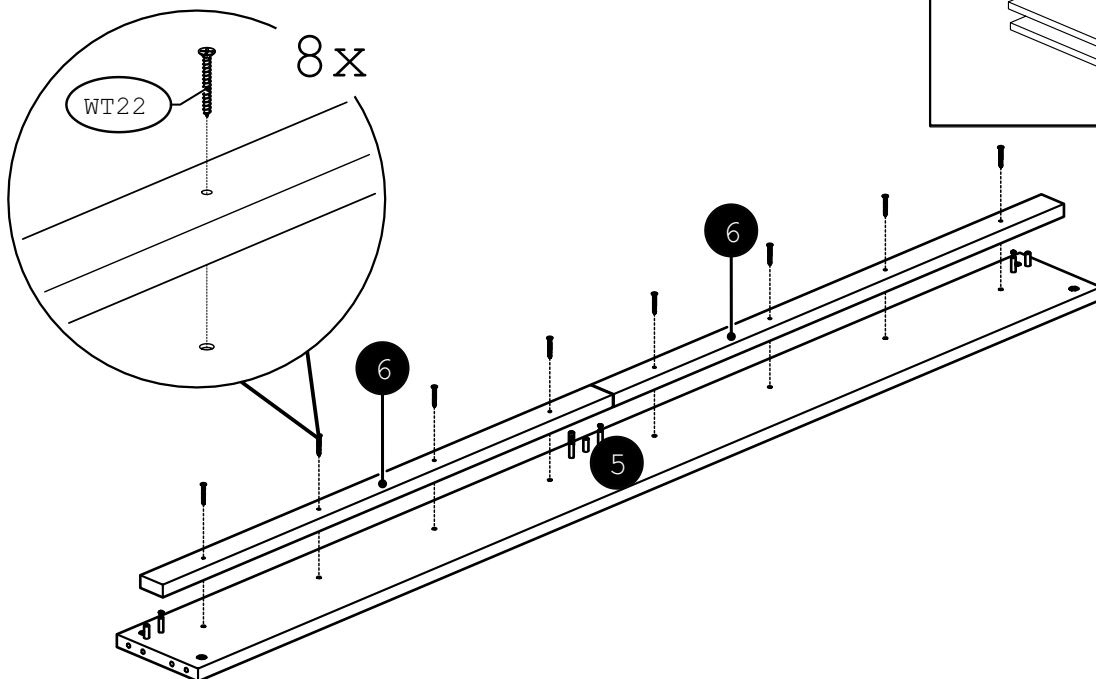
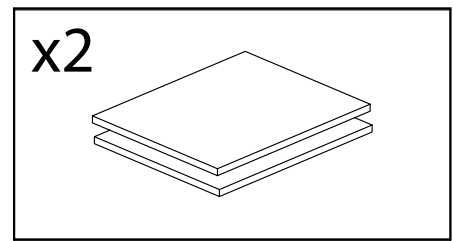
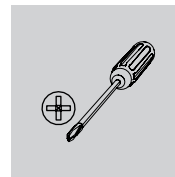
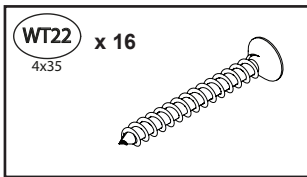

4

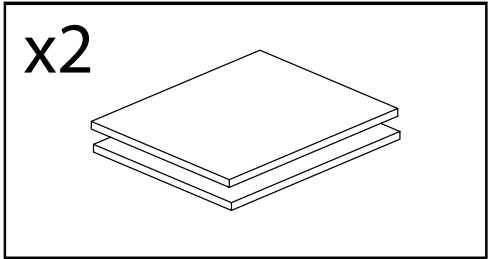
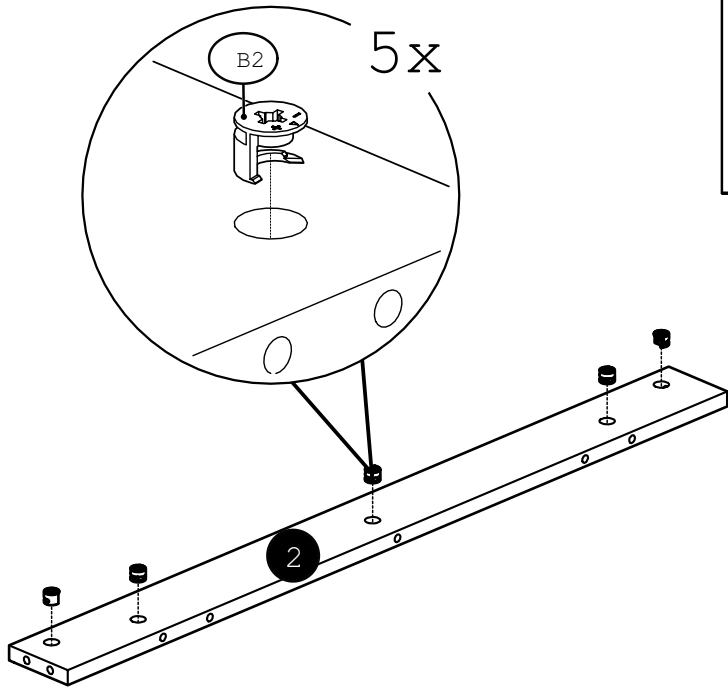
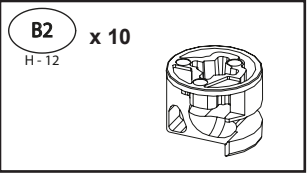

5

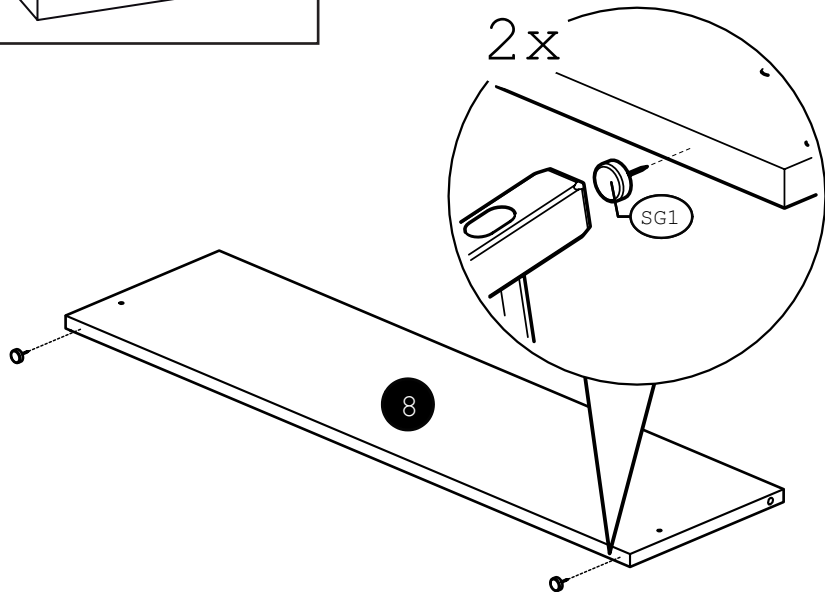
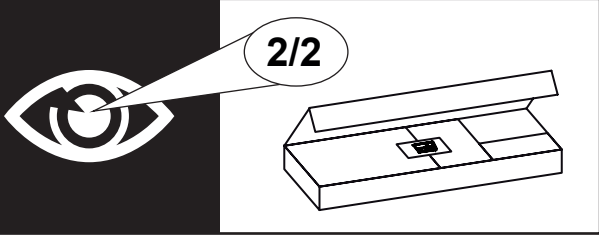
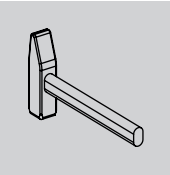
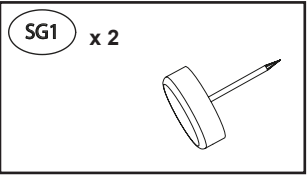

6

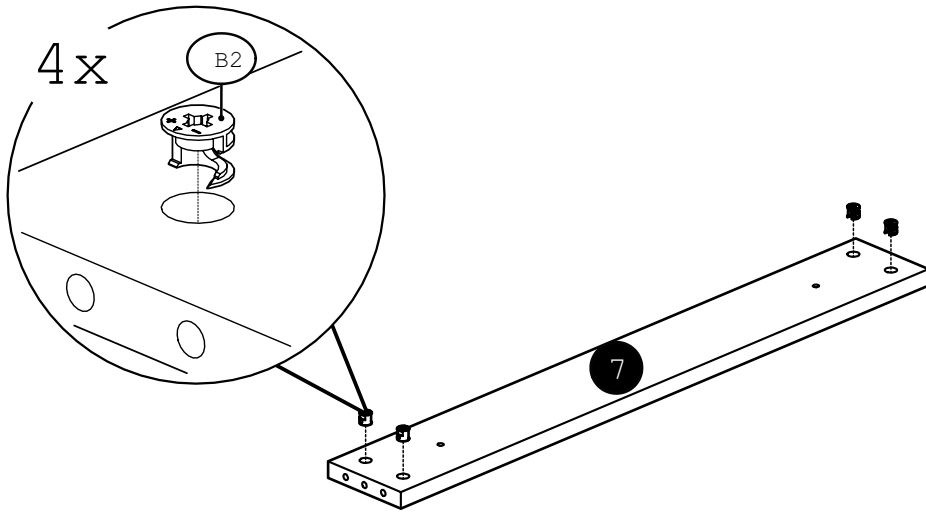
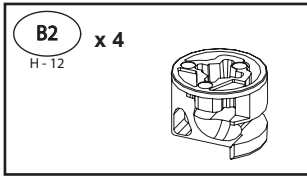

7

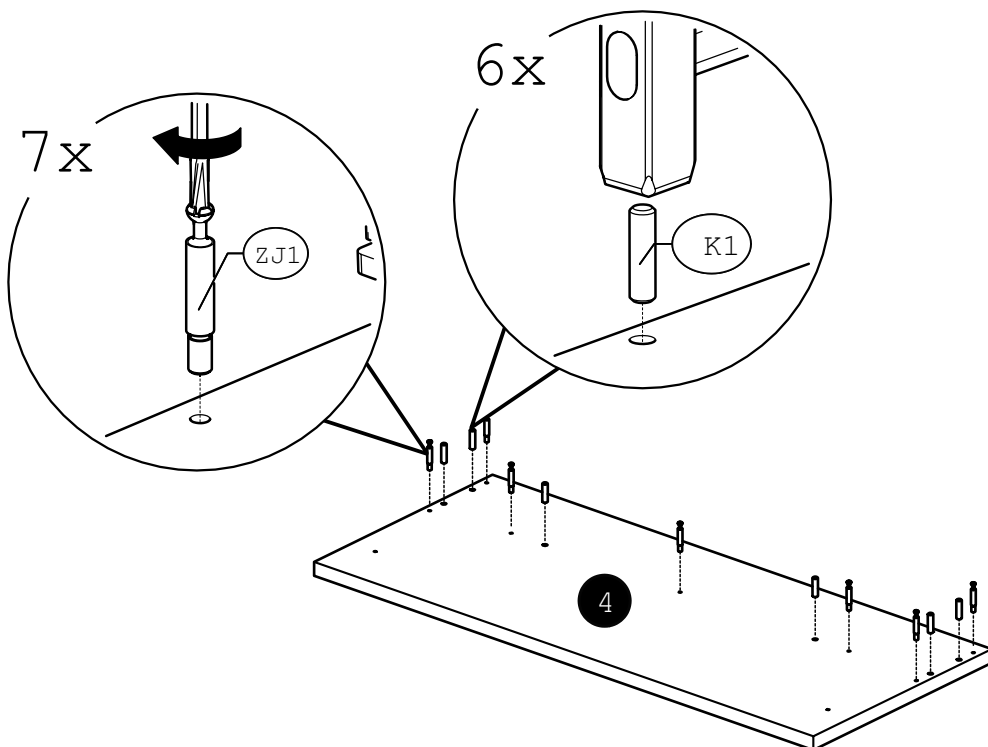
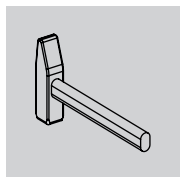
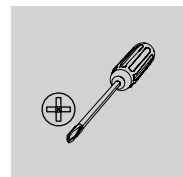
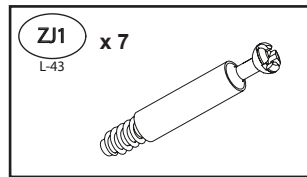
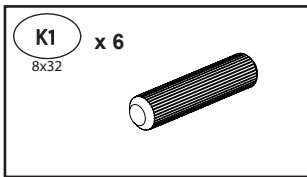



8

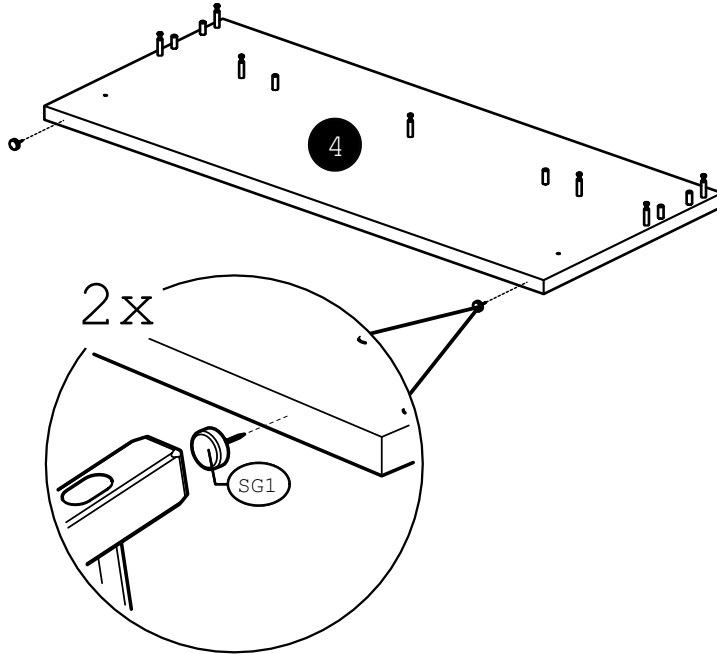
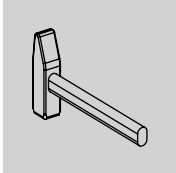
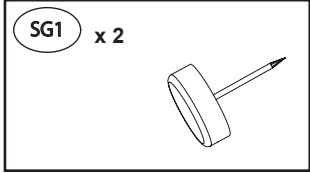

9

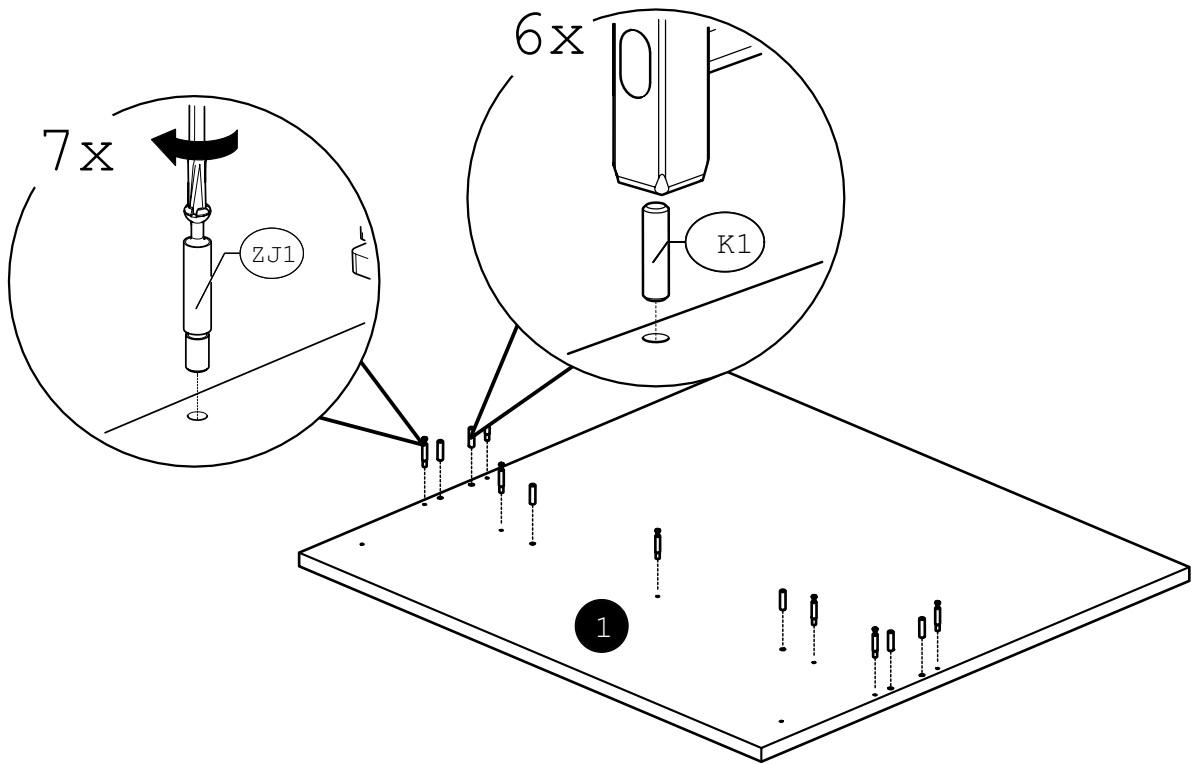
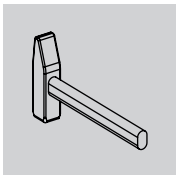
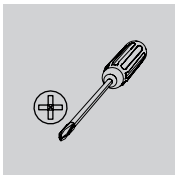
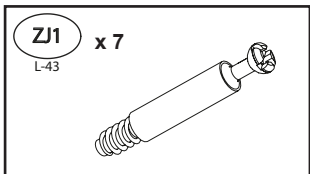
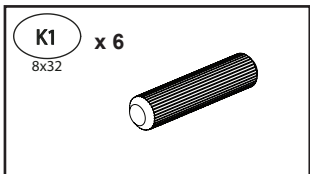

10

SG1 x 2

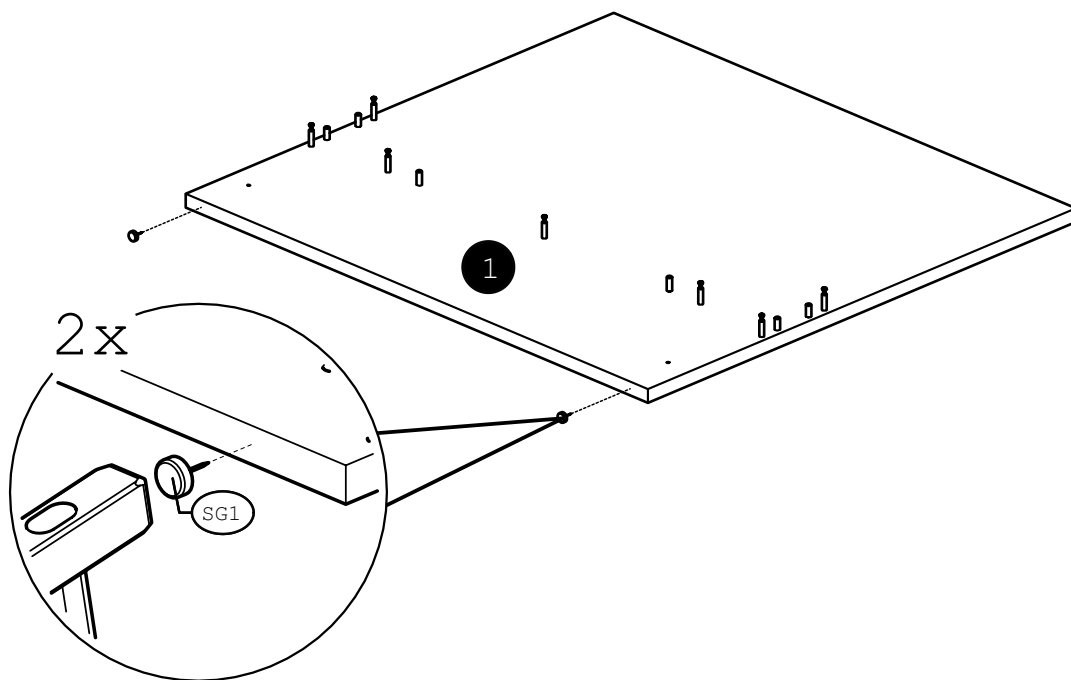
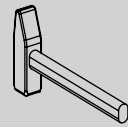
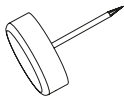

11

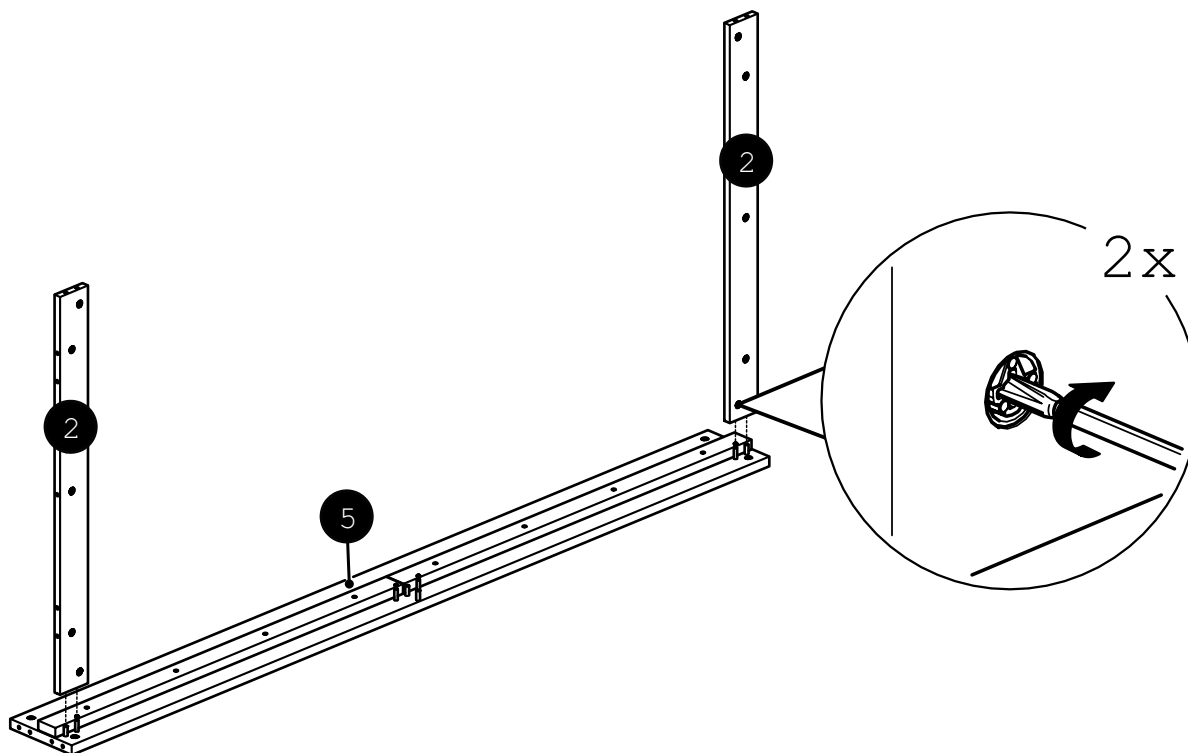
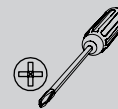

12

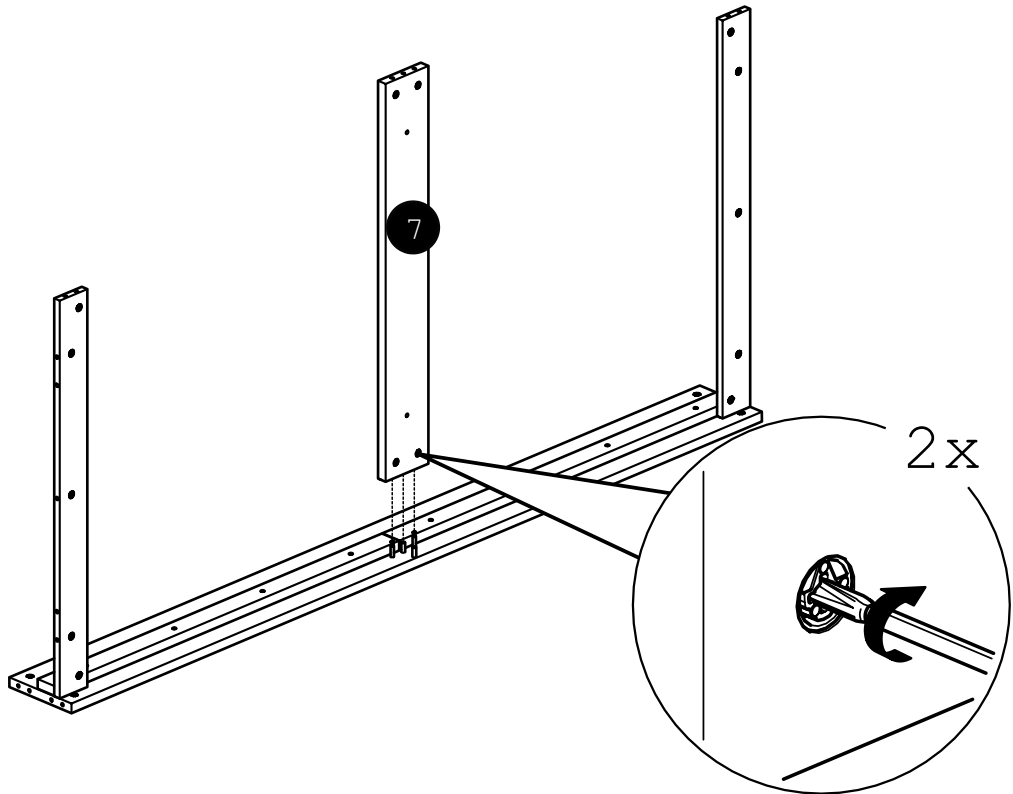
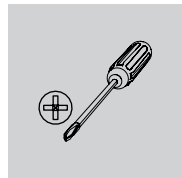

13

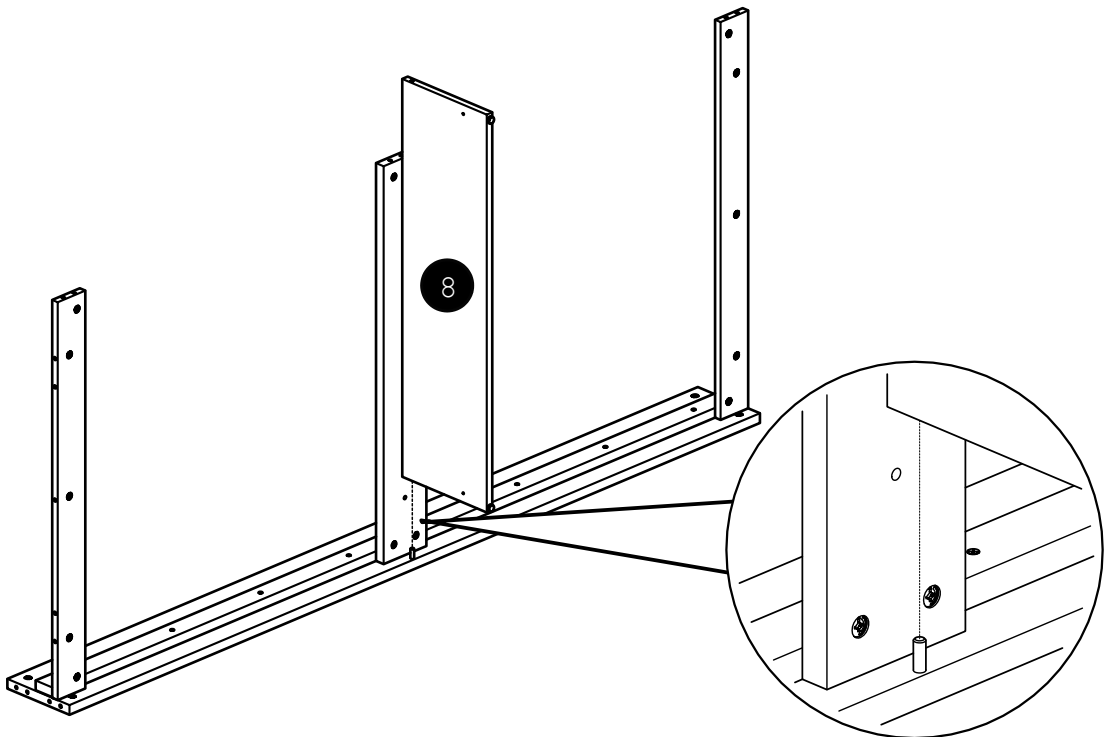

14

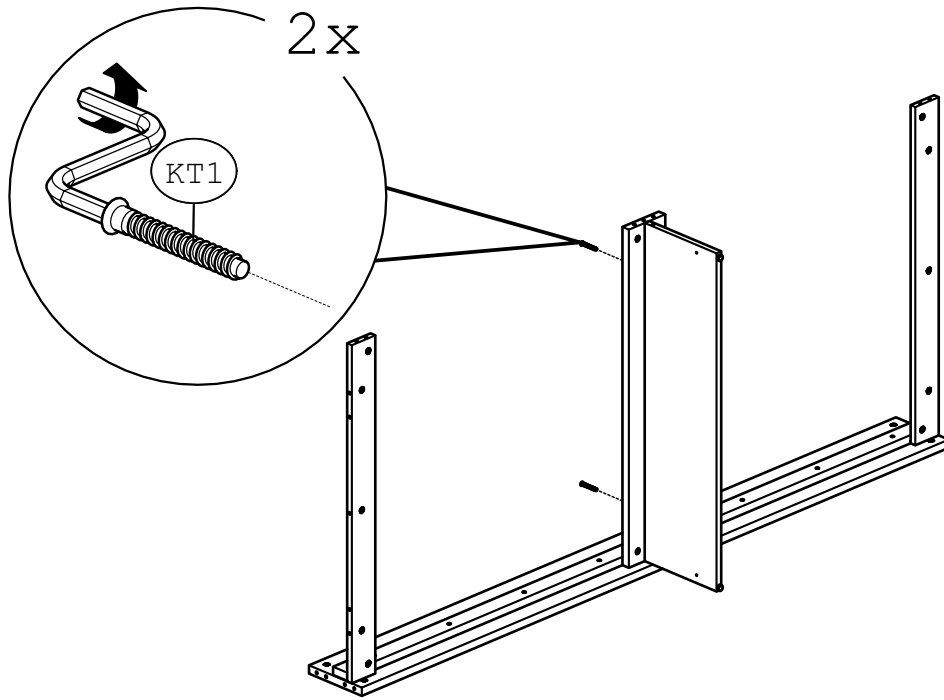
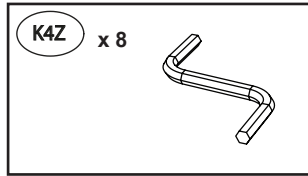
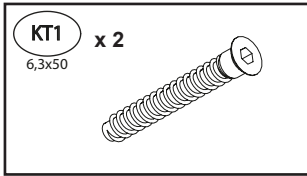

15

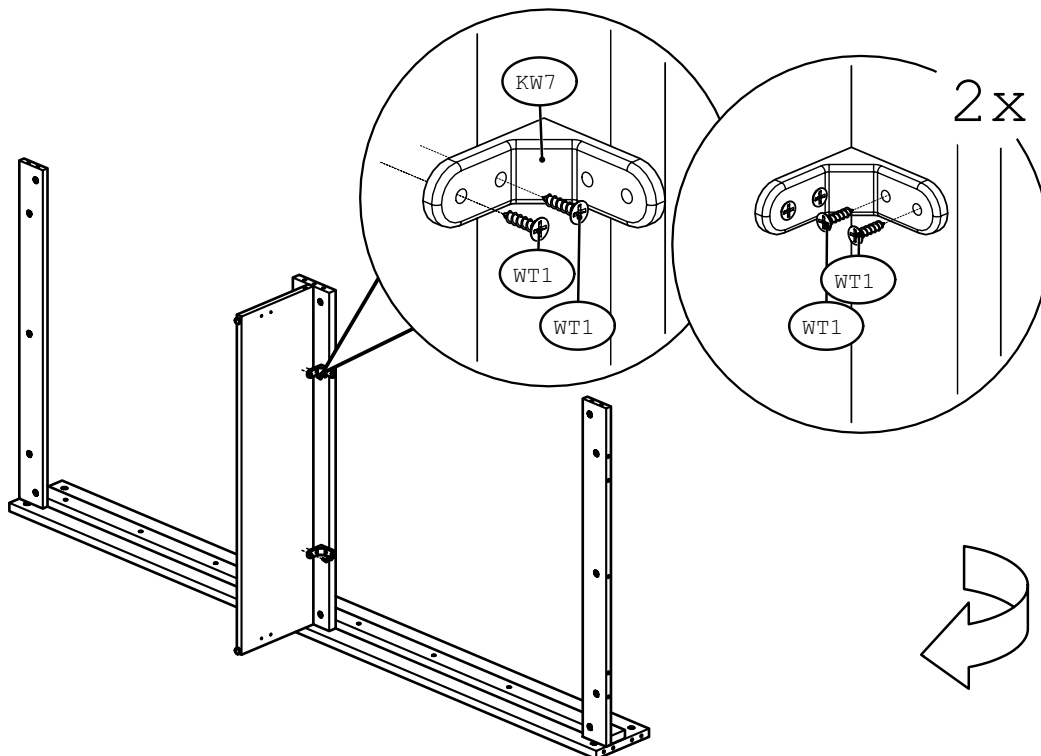
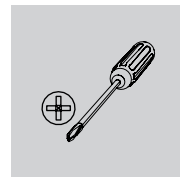
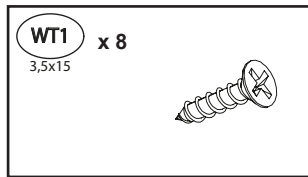
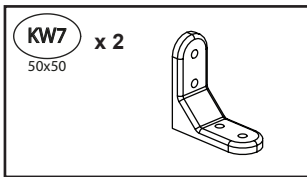

16

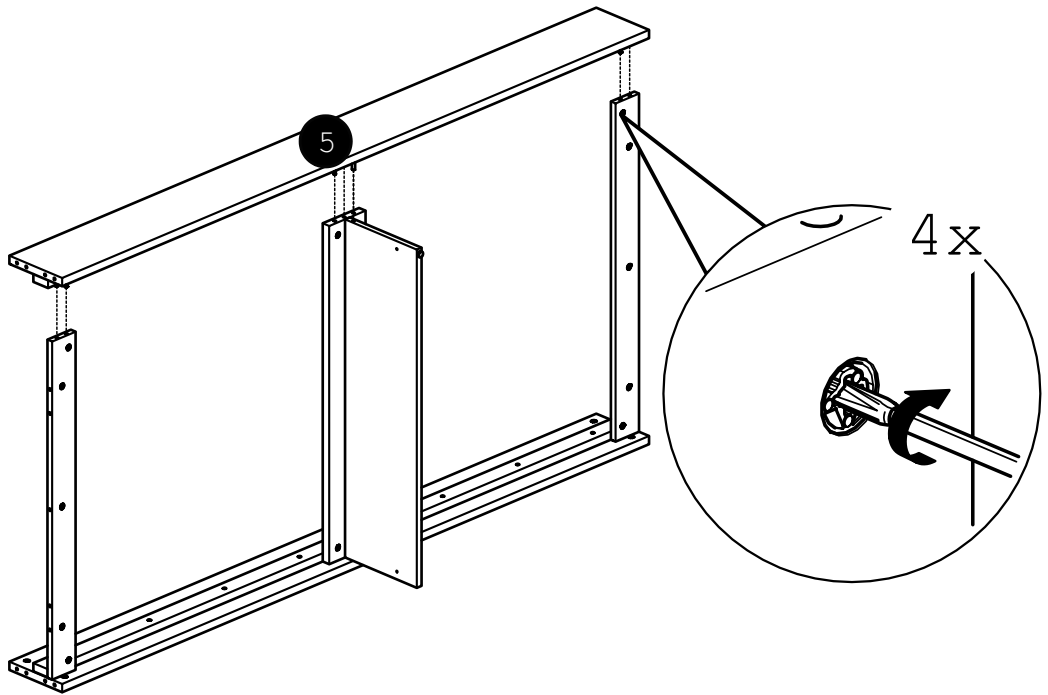
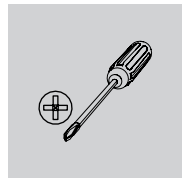

17

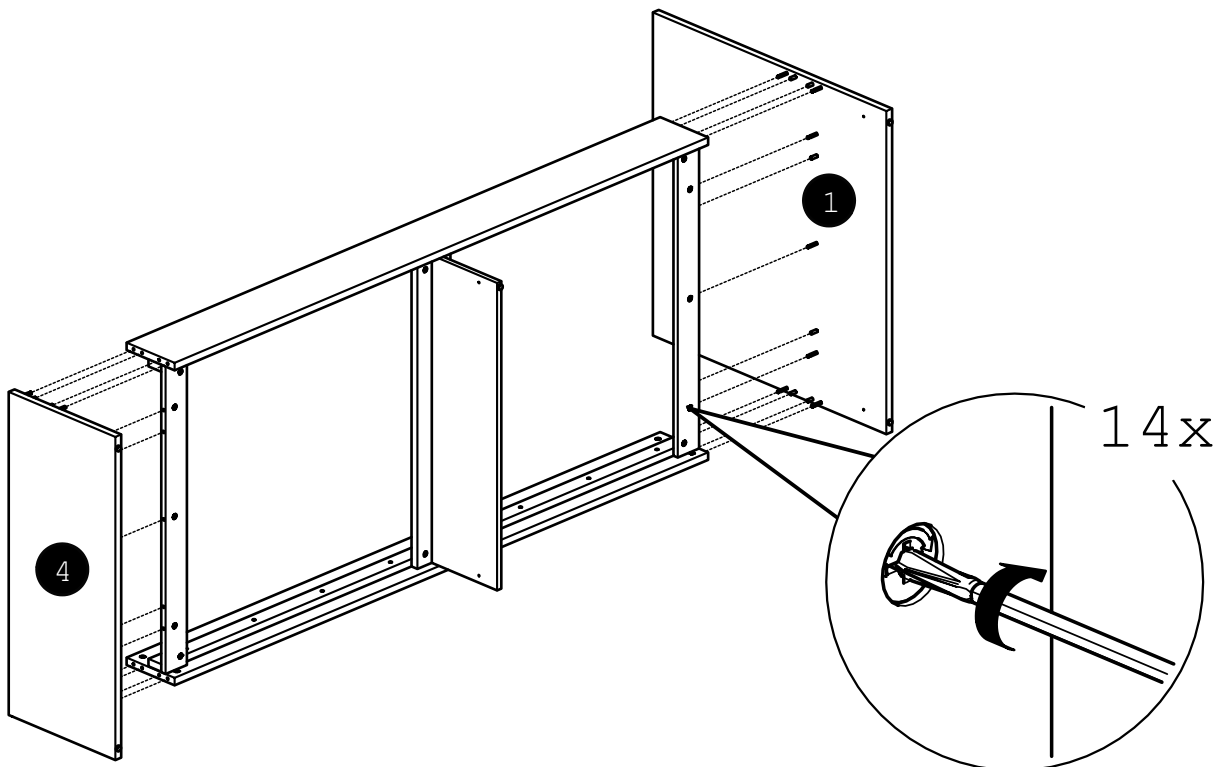
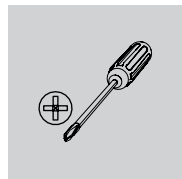

18

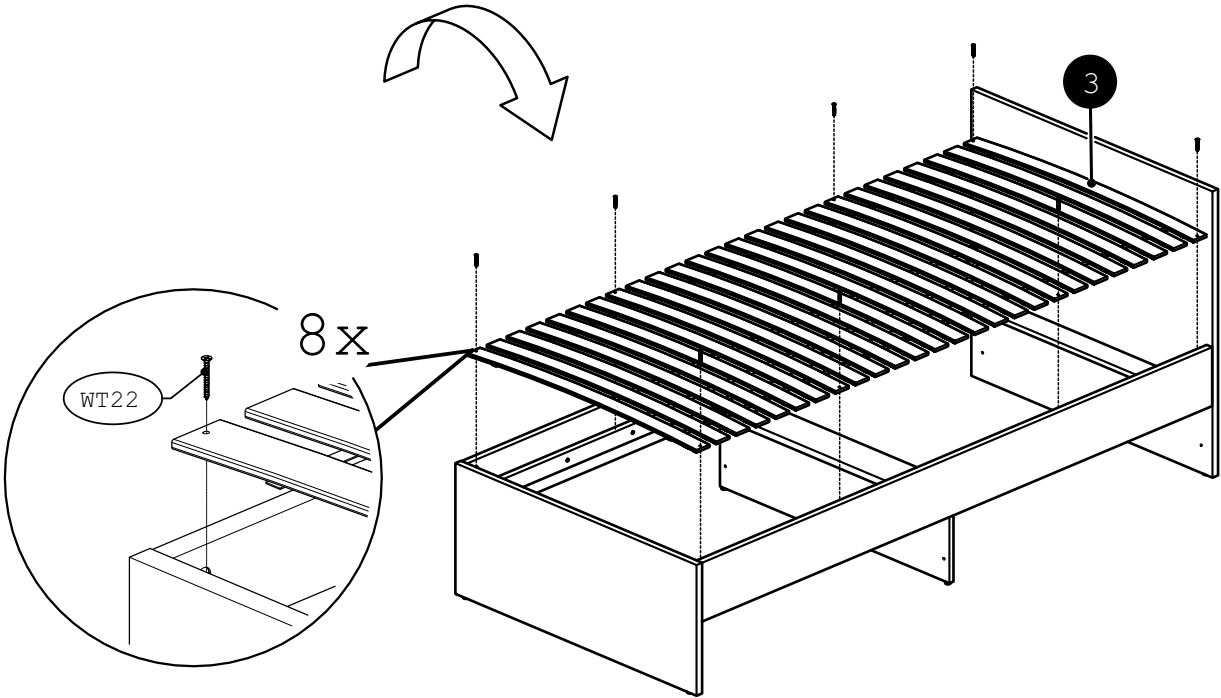
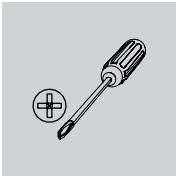
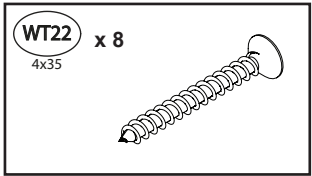

19

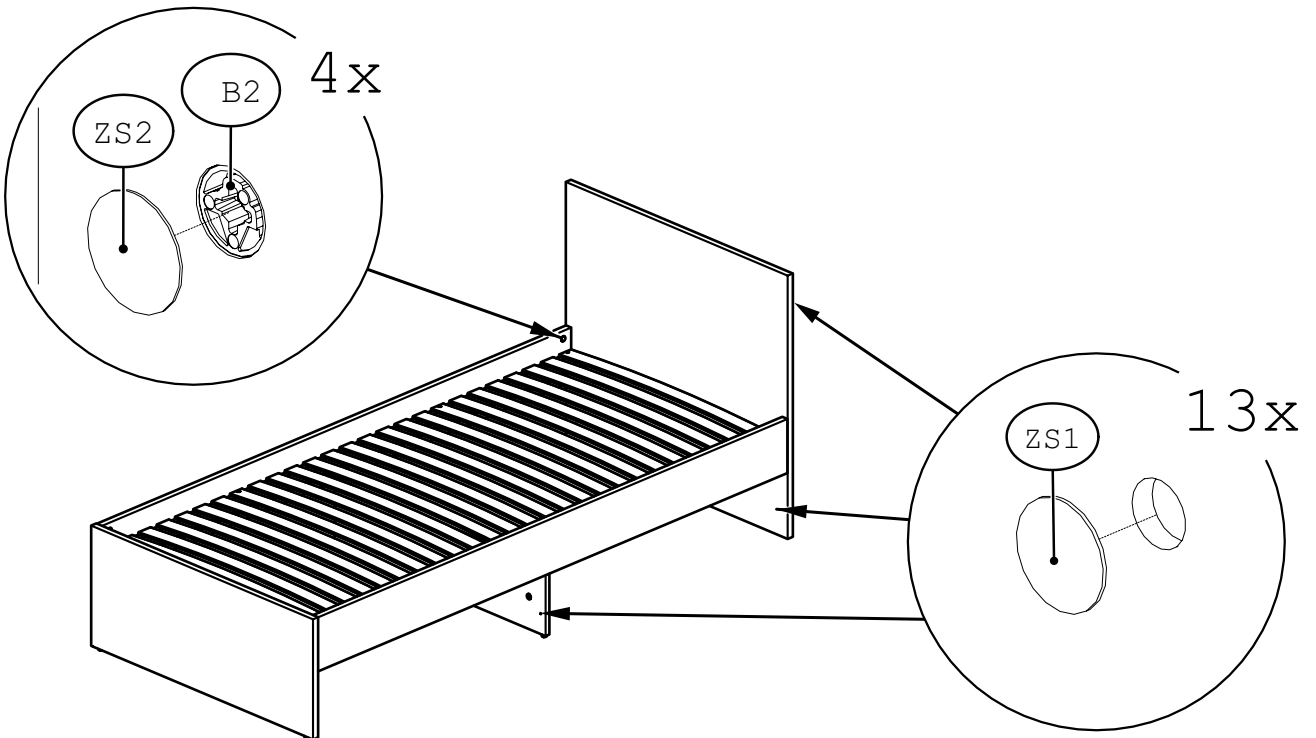
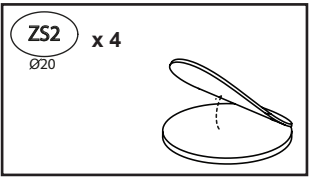
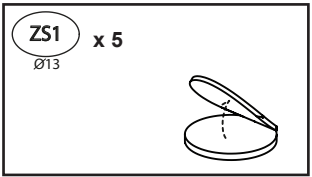
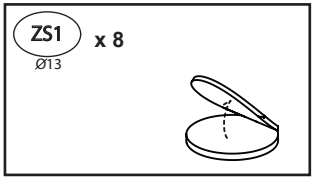

20



21

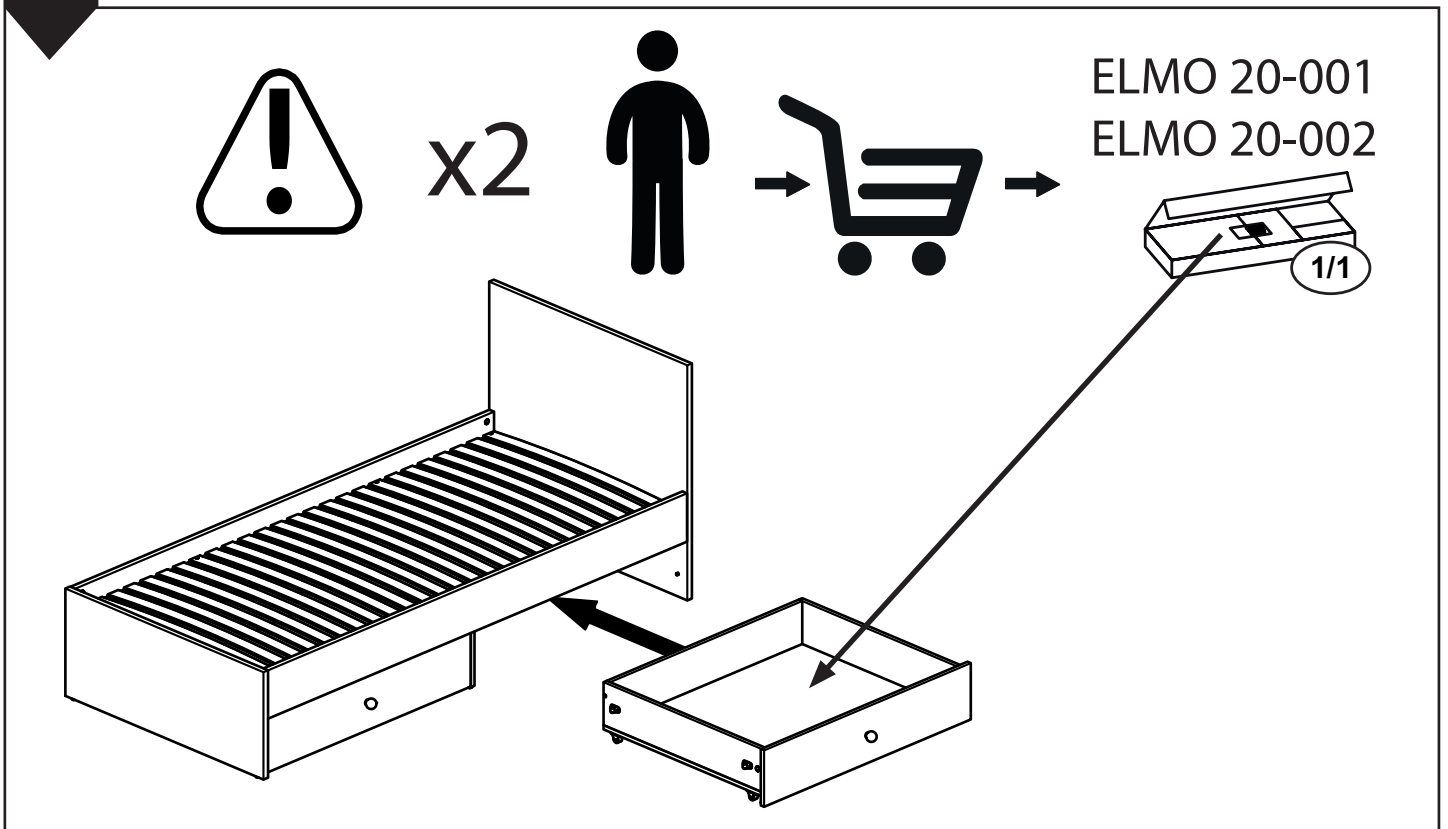



ZAG 07-001

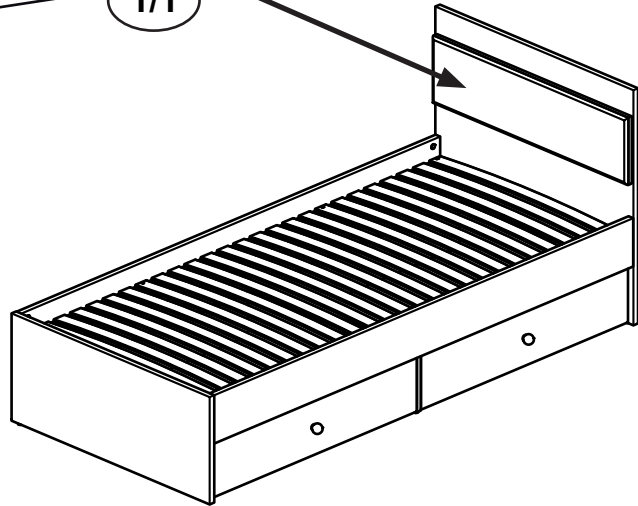
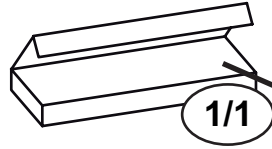



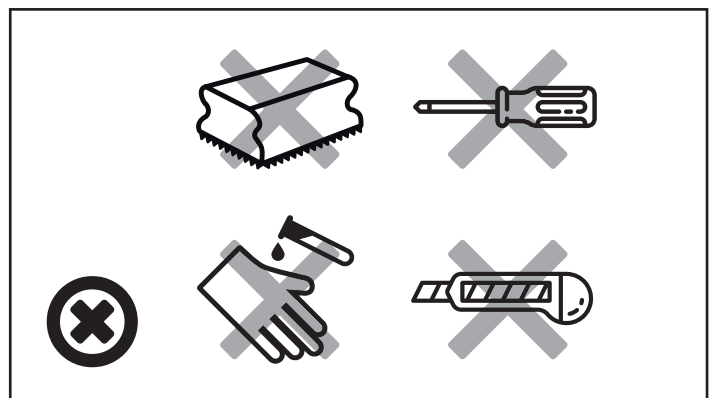
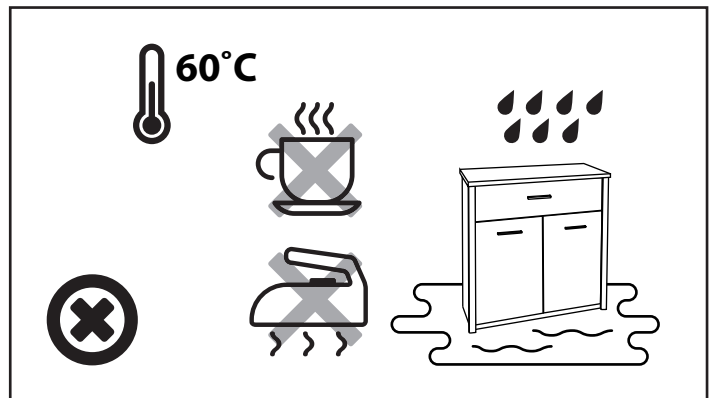
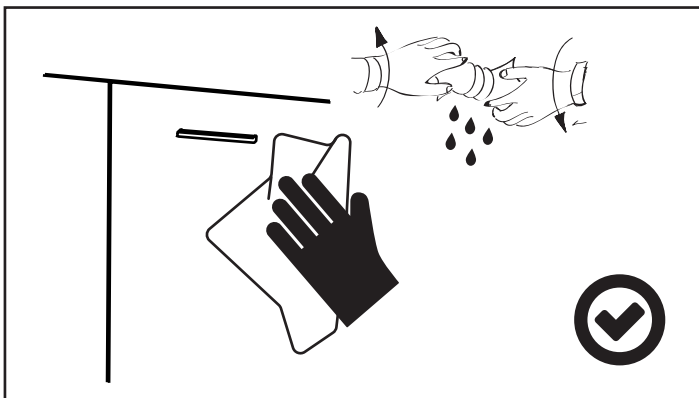
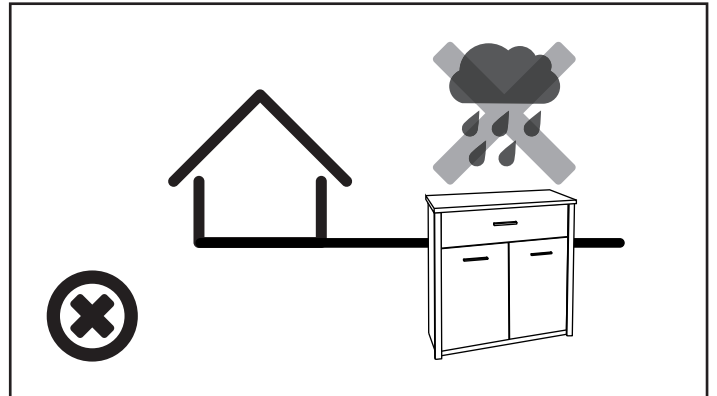
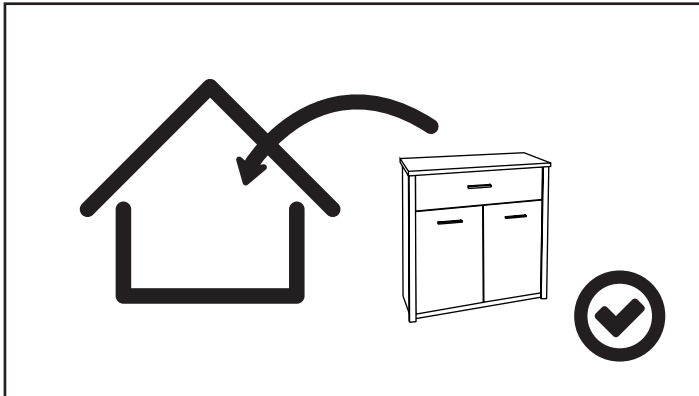
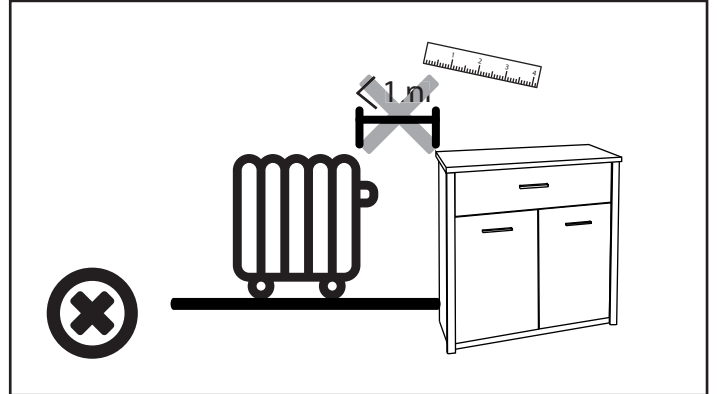
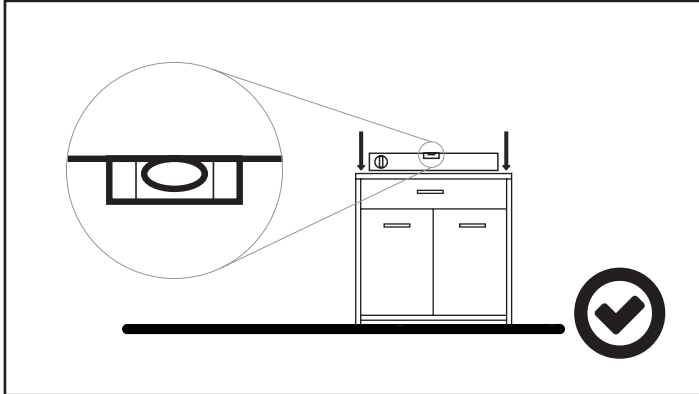



# ELMO 19

PL - Instrukcja montażu / BG - Сглобяване инструкция / CZ - Montáž instrukce / DE - Montageanleitung / EN - Assembling instruction / ES - Montaje de instrucción / EST - Paigaldusjuhend / FR - Notice de montage / HR - Sastavljanje upute / HU - Szerelési utasítás / I - Istruzioni di montaggio / LT - Montavimo instrukcija / LV - Montāžas instrukcija / NL - Montage instructie / P - Montagem de instrução / RO - Asamblarea de instrucțiuni / RU - Инструкция сборки / S - Montering instruktion / SK - Montáž inštrukcie / SLO - Sestavljanje navodila / SRB - Skлапање инструкцију / TR - Kurulum Talimatları / UKR - Збірка інструкція /

PL - Przed rozpoczęciem zapoznać się z instrukcją montażu / BG - Преди да започнете се отнасят към инструкциите за инсталиране / CZ - Před zahájením naleznete v montážním návodu / DE - Vor die montage, bitte beiliegende anweisungen folgen / EN - Before starting, refer to the assembling advice in annex / ES - Antes de començar referirse a las instrucciones de instalación / EST - Enne käivitamist vaadake paigaldusjuhiseid / FR - Avant de commencer, se reporter aux conseils de montage en annexe / HR - Prije početka pogledajte upute za instalaciju / HU - Megkezdése előtt olvassa el a telepítési utasításokat / I - Avanti di cominciare, riportate agli consigli di montaggio / LT - Prieš pradant kreiptis į montavimo instrukcija / LV - Pirms sākt montāžu, iepazīties ar instrukciju / NL - Voordat u begint Zie de installatie-instructies / P - Antes de começar a consultar as instruções de instalação / RO - Înainte de a începe să consultați instrucțiunile de instalare / RU - Перед началом обратитесь к инструкции по установке / S - Innan du börjar se Installationsanvisningen / SK - Pred začatím nájdete v montážnom návode / SLO - Pred začetkom glejte navodila za namestitev / SRB - Пре почетка погледајте упутства за инсталацију / TR - Kurulumla başlanmadan önce, montaj talimatnamesini sırasıyla takip edin. / UKR - Перед початком зверніться до інструкції з установки /

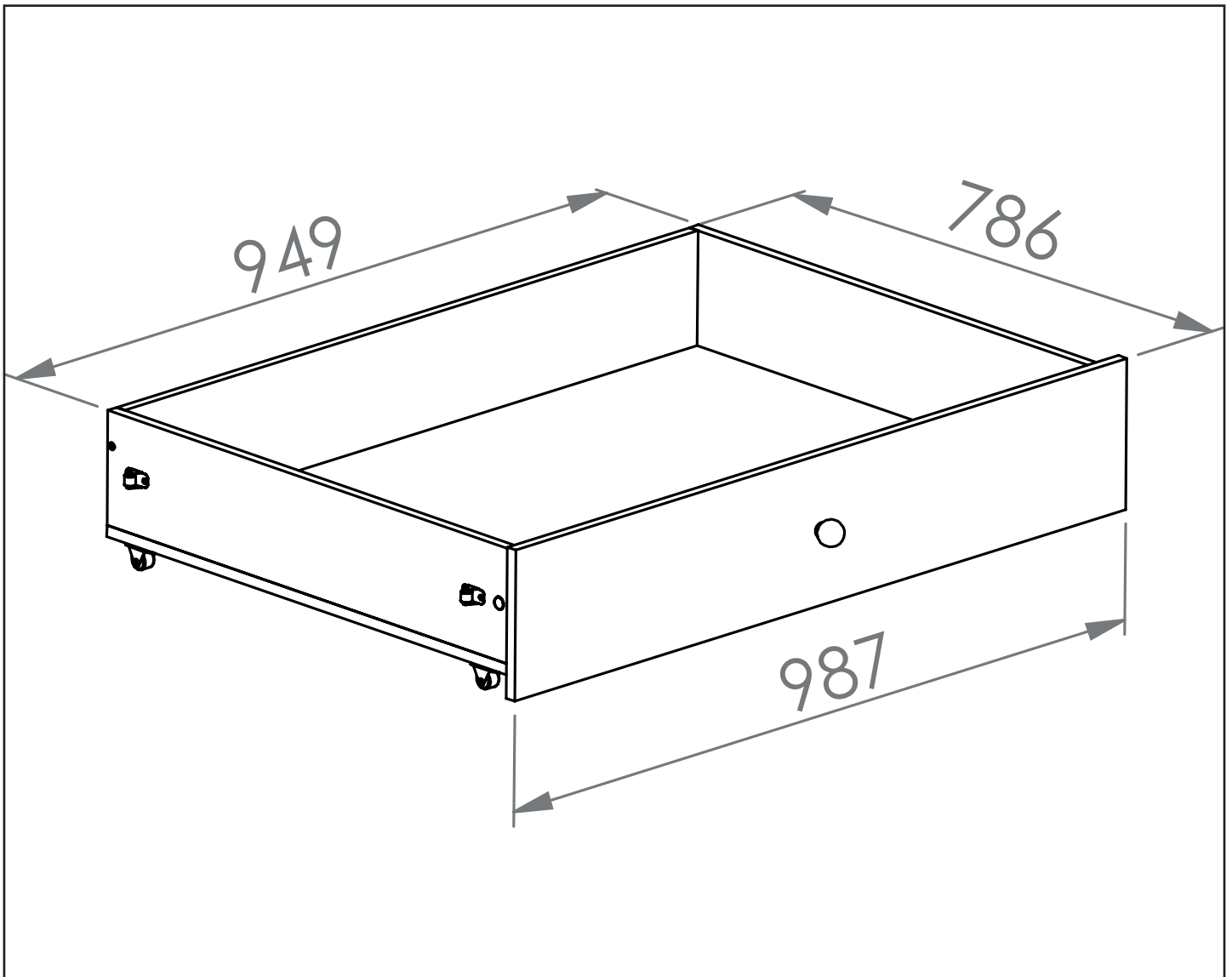
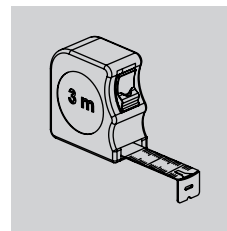
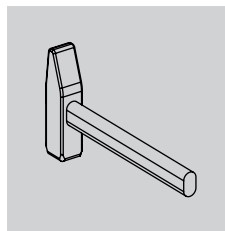
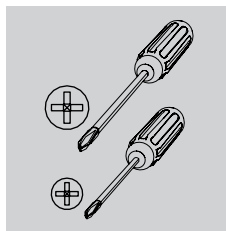
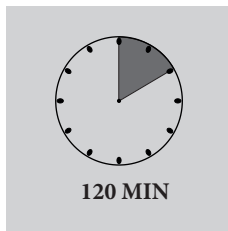
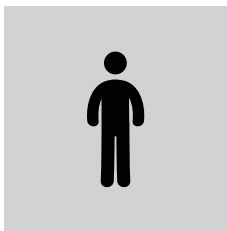

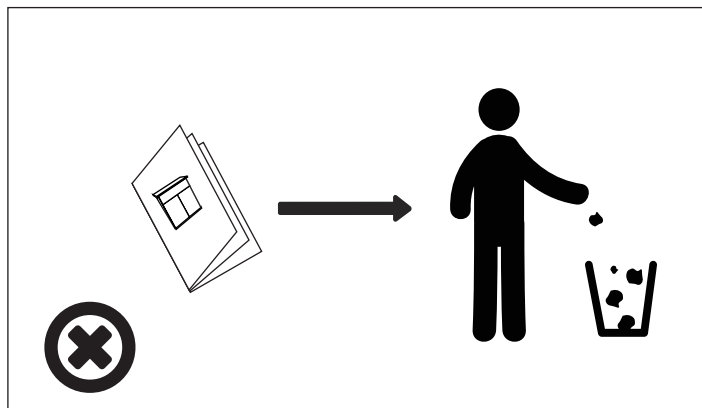
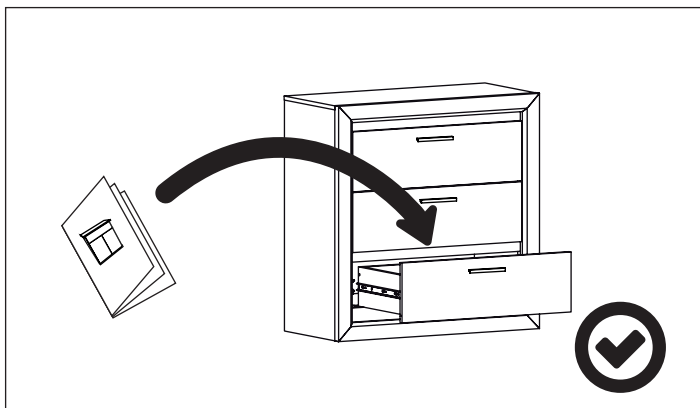
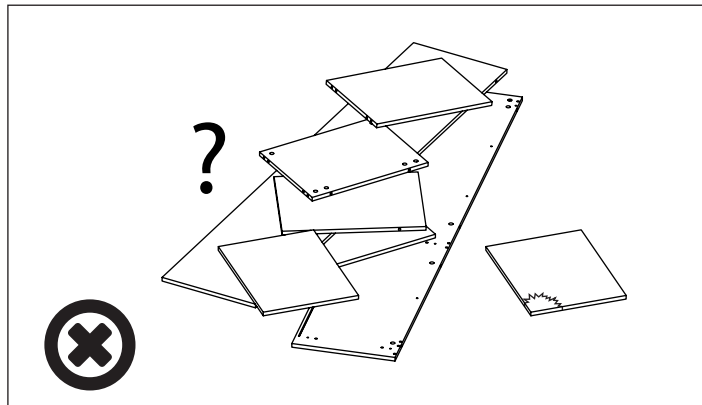
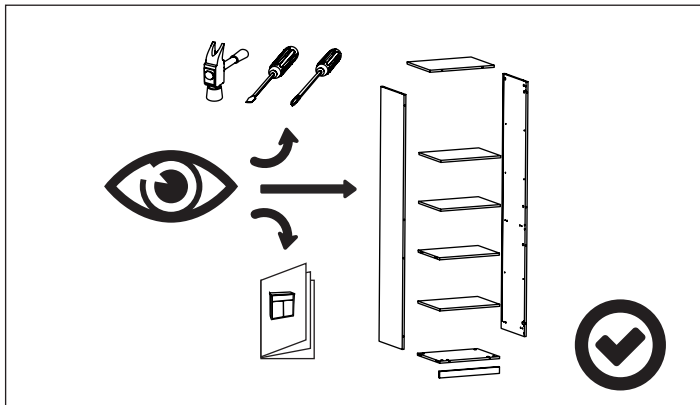
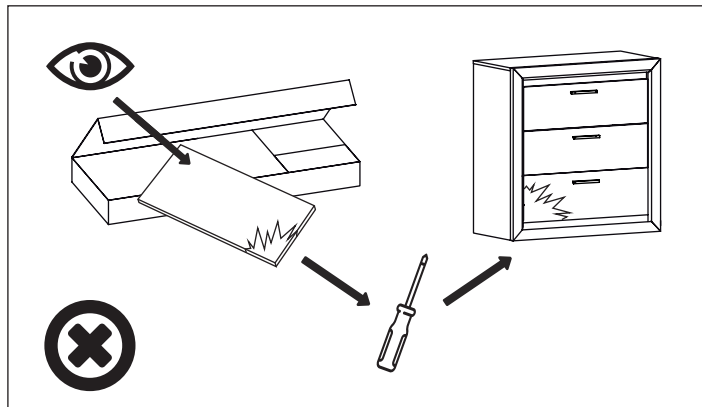
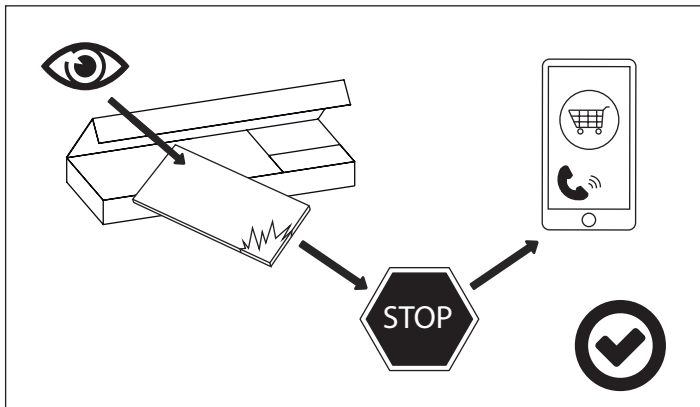
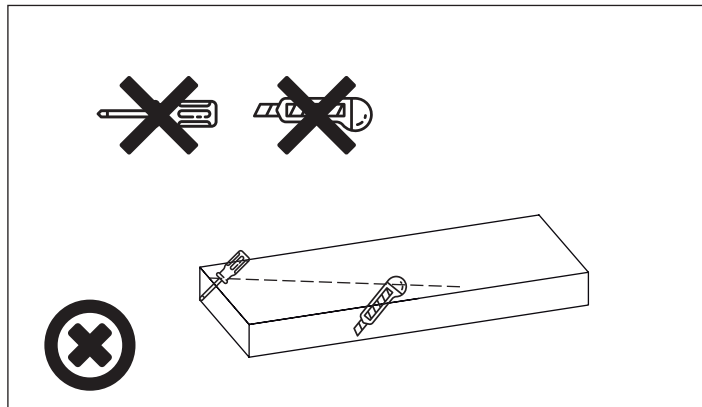
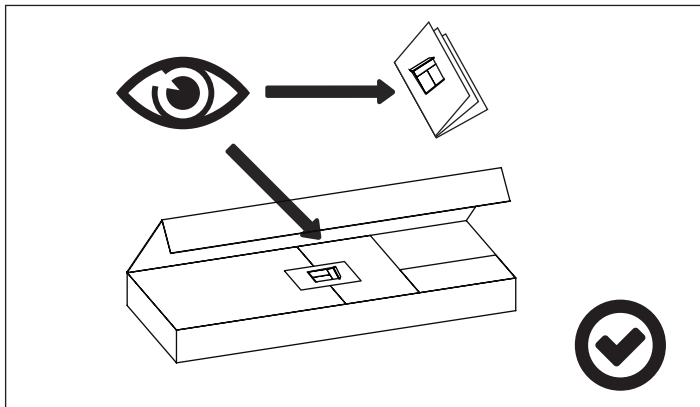

	CODE				
1	Elmo19_04	917	160	1	1/1
2	Elmo19_01	987	210	1	1/1
3	Elmo19_05	949	770	1	1/1
4	Elmo19_03	160	770	1	1/1
5	Elmo19_02	160	770	1	1/1
6					
7					
8					
9					
10					
11					
12					
13					
14					
15					

	CODE				
16					
17					
18					
19					
20					
21					
22					
23					
24					
25					
26					
27					
28					
29					
30					

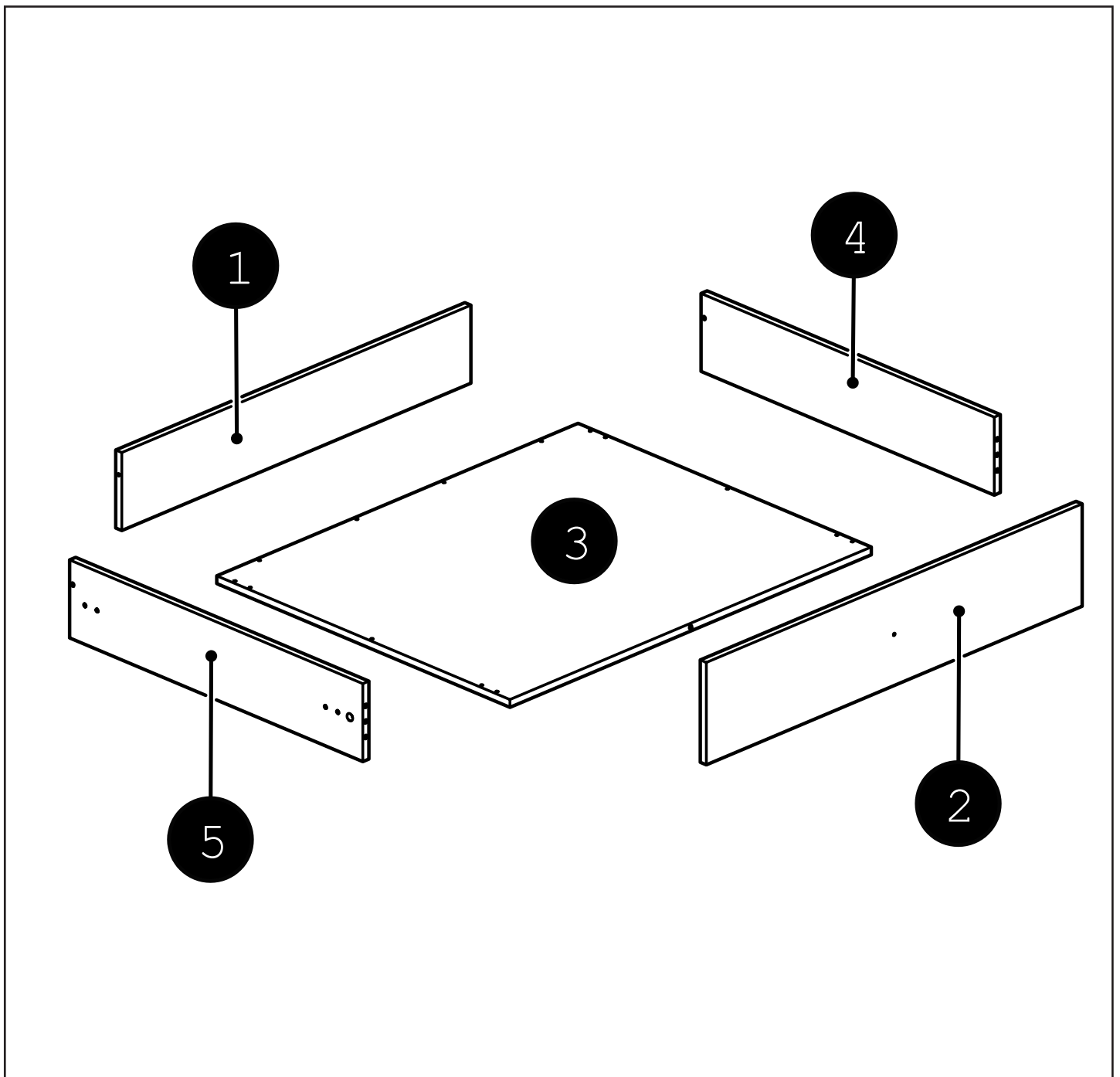

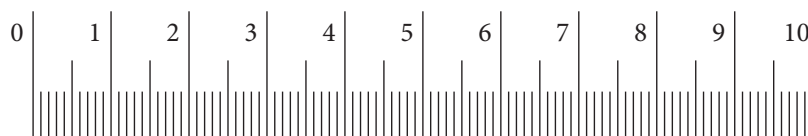
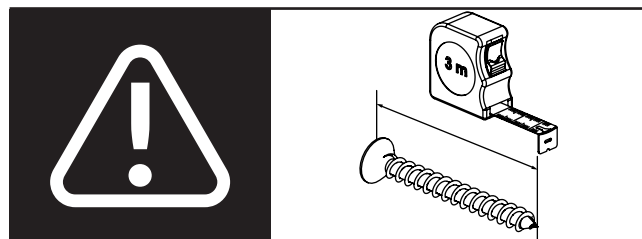
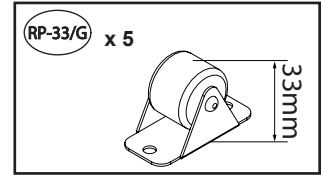
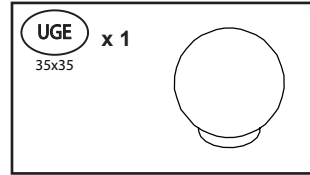
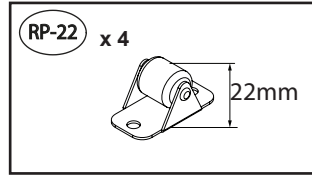
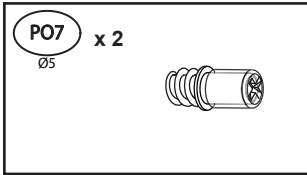
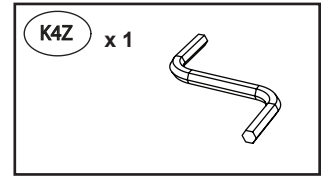
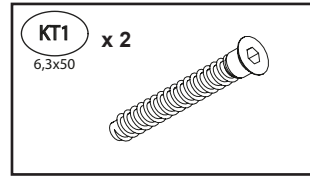
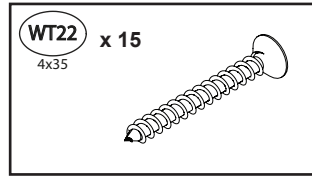
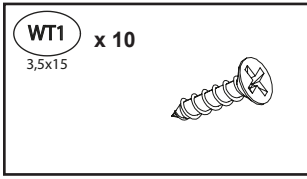
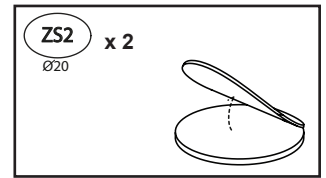
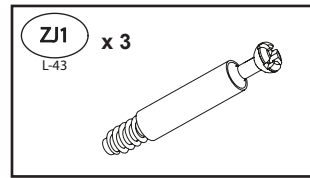
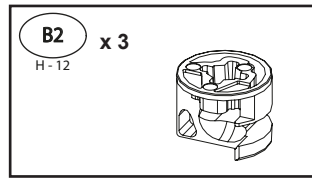
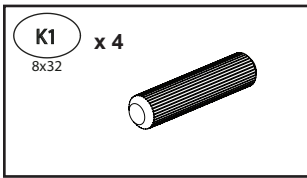

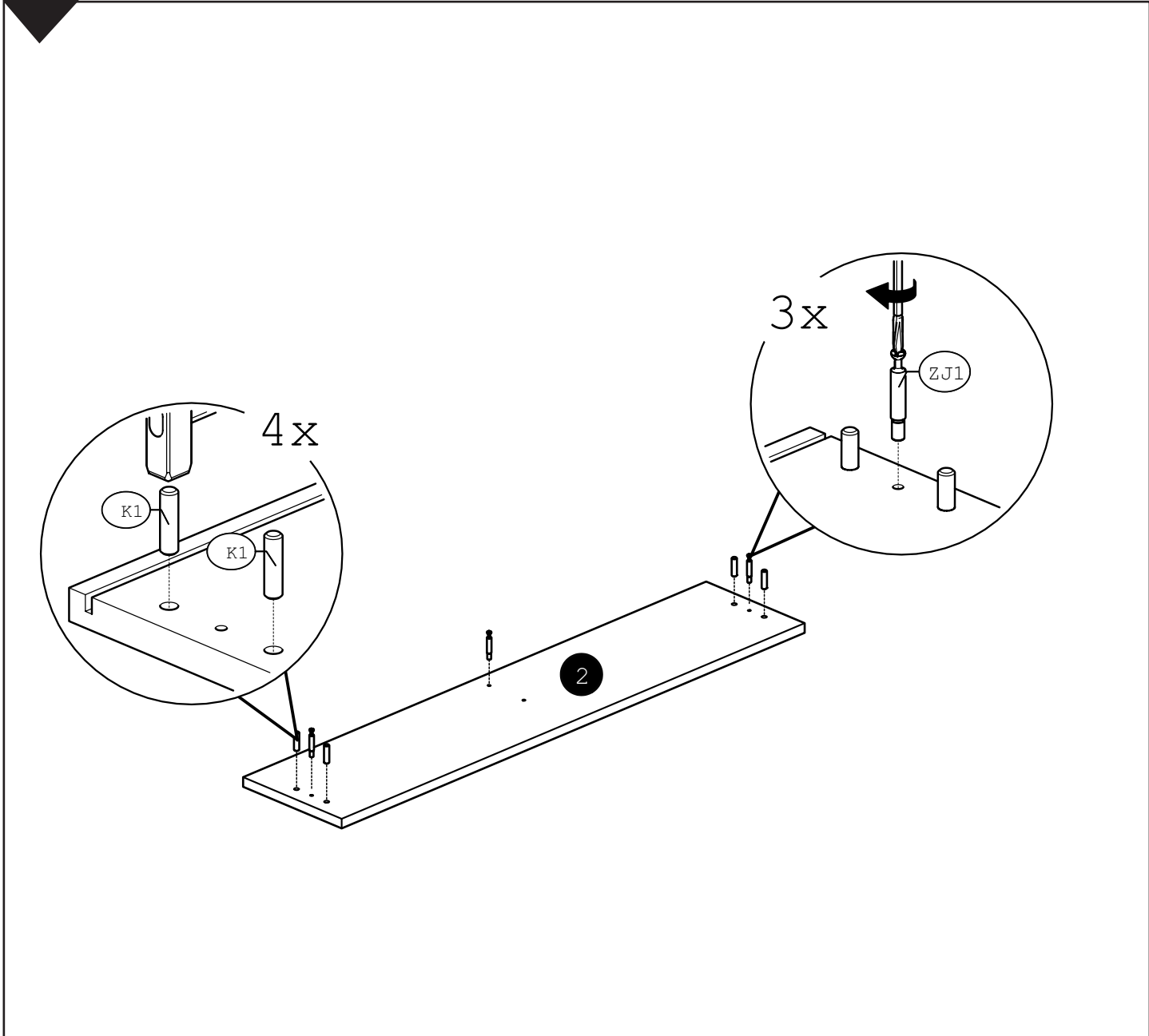
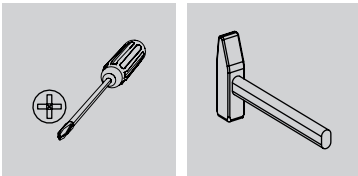
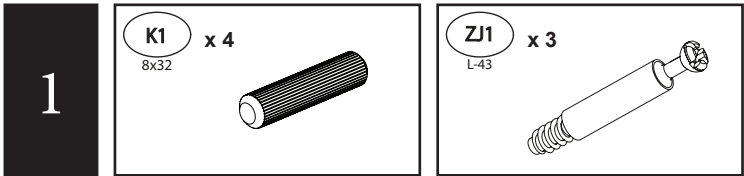
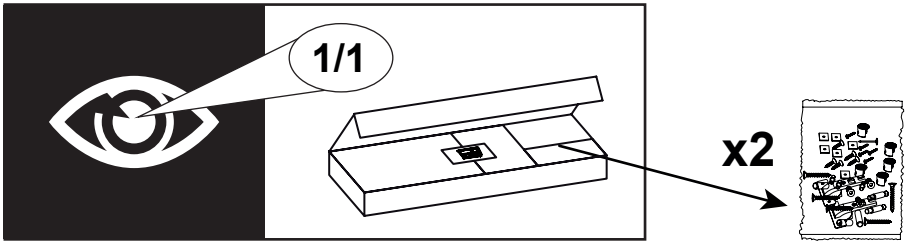
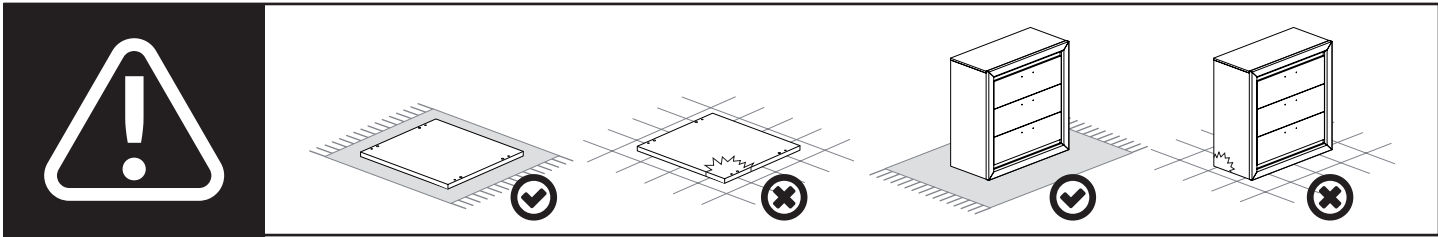

2

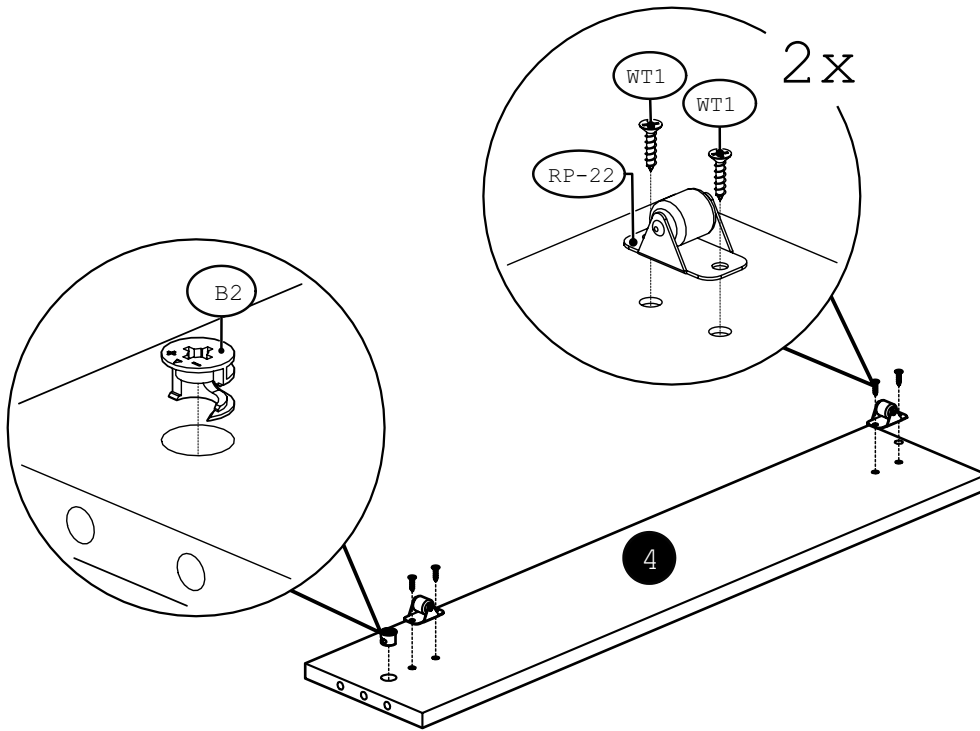
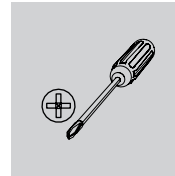
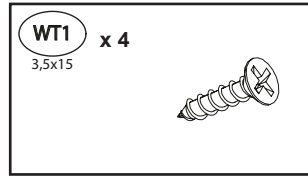
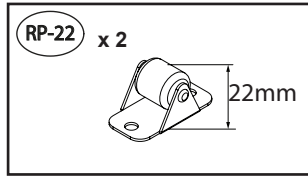
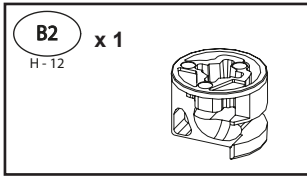

3

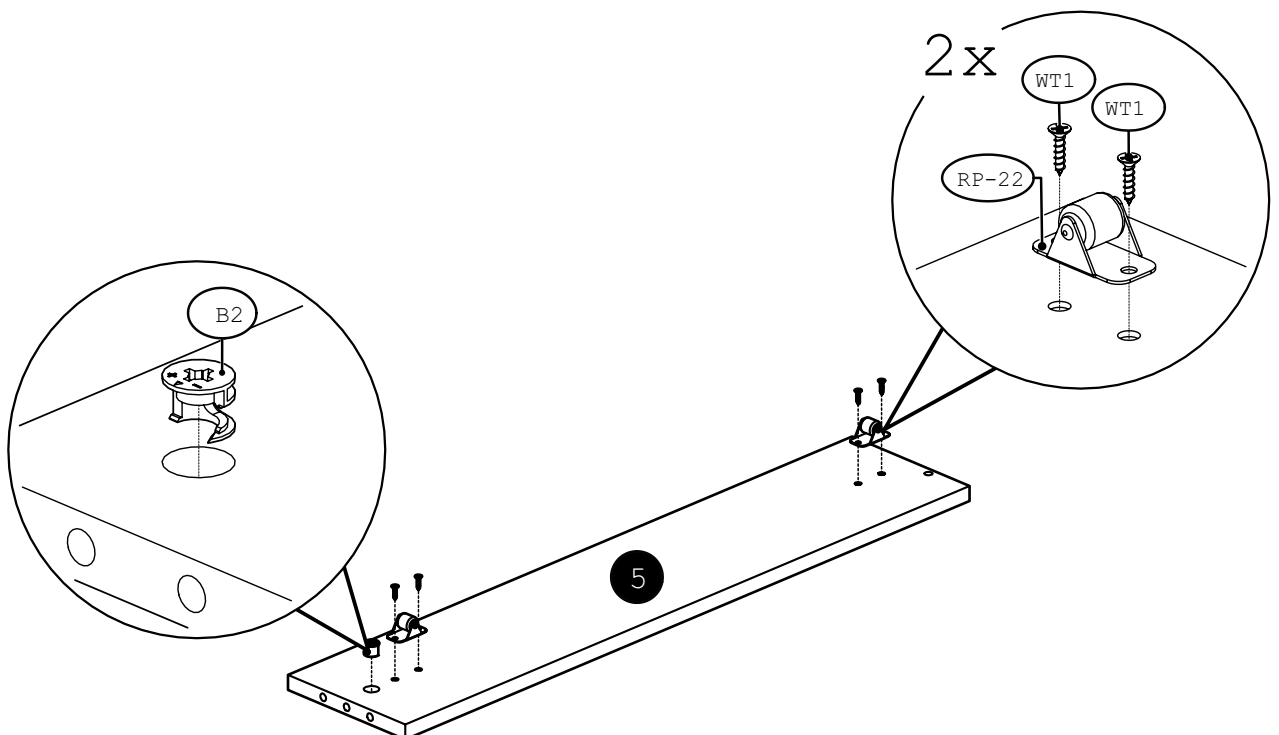
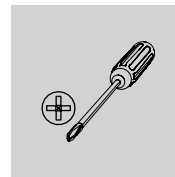
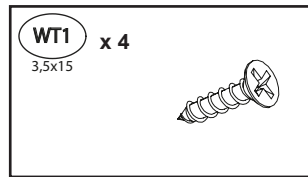
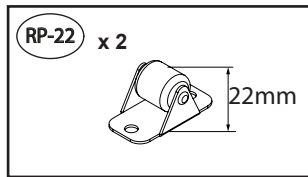
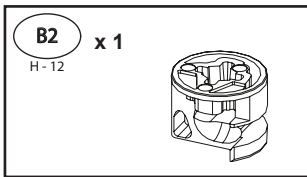

4

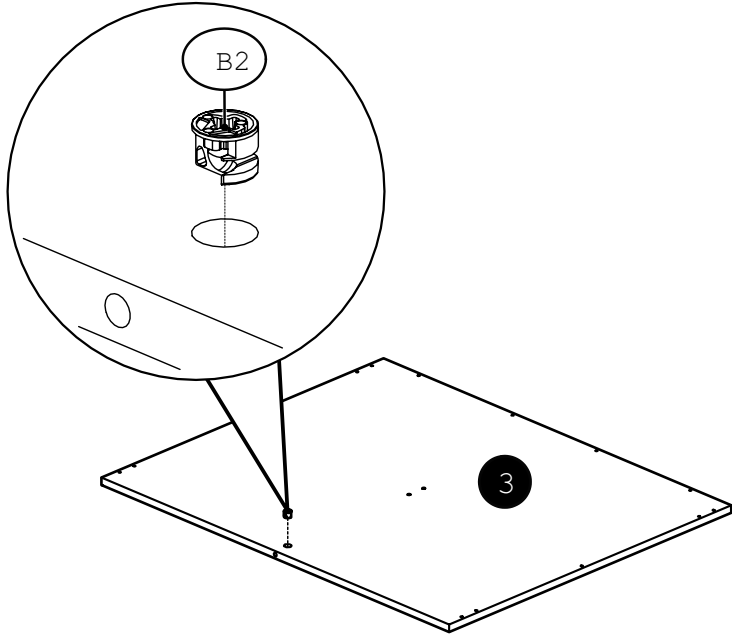
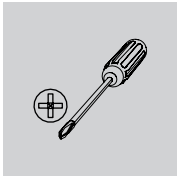
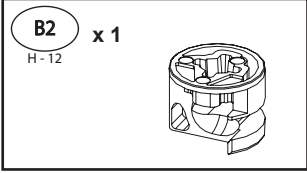

5

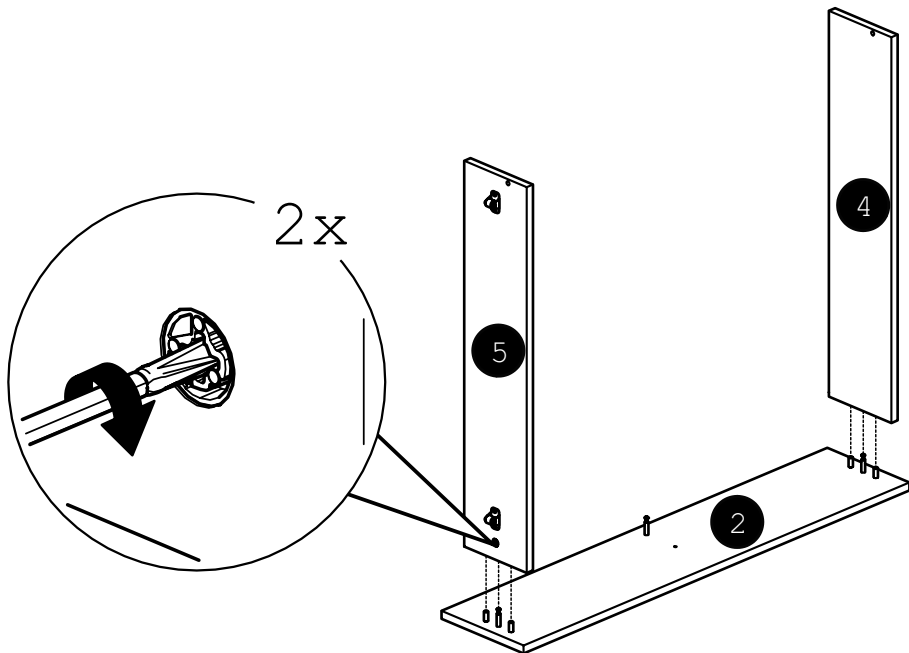
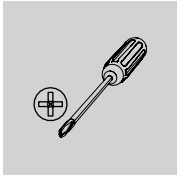



6

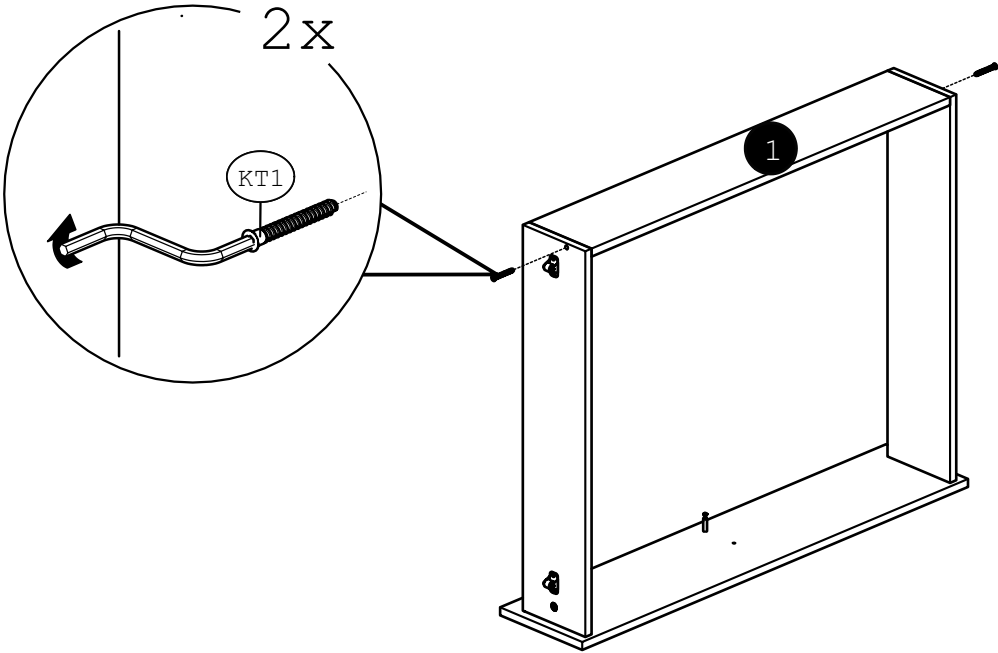
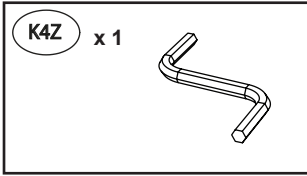
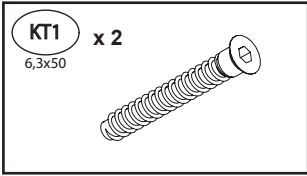

7

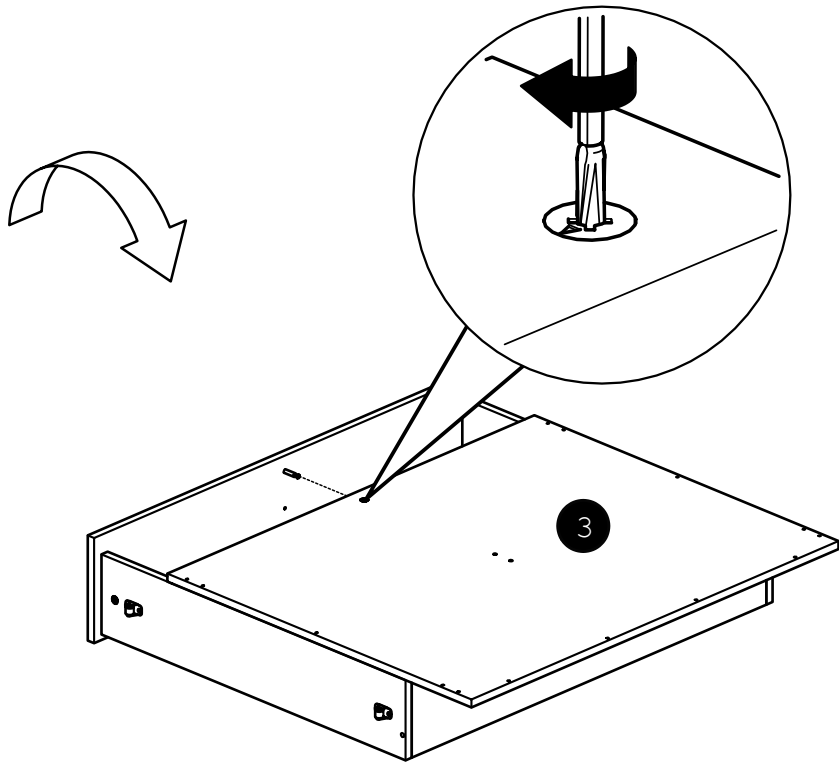
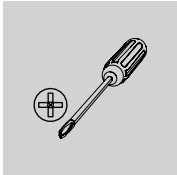

8

WT22 x 6  
4x35

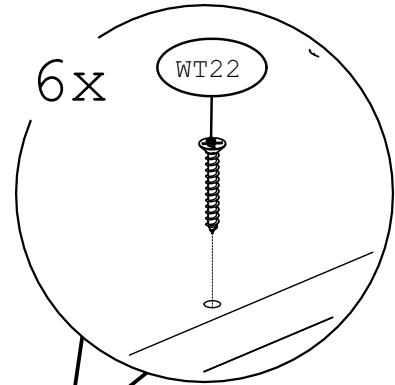
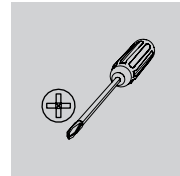
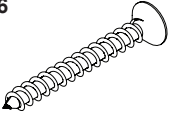

6x

WT22

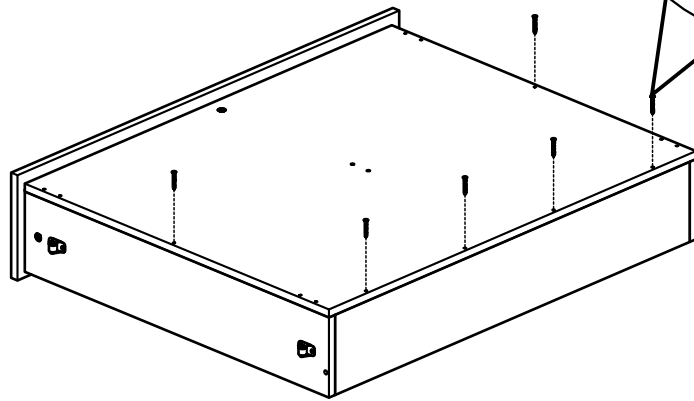
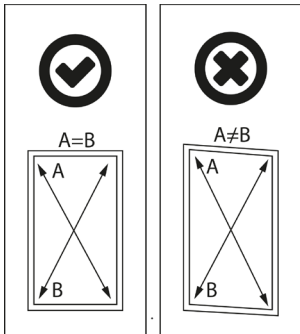

9

RP-33/G x 4

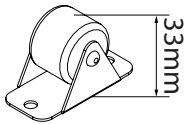

WT22 x 8  
4x35

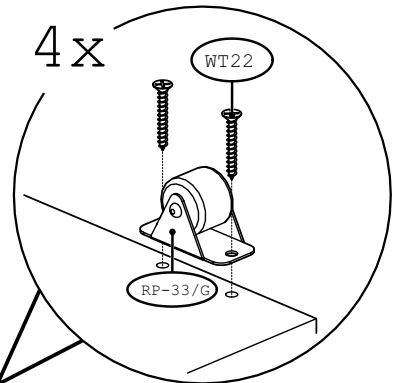
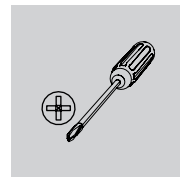
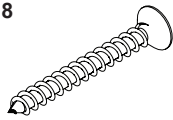

4x

WT22

RP-33/G

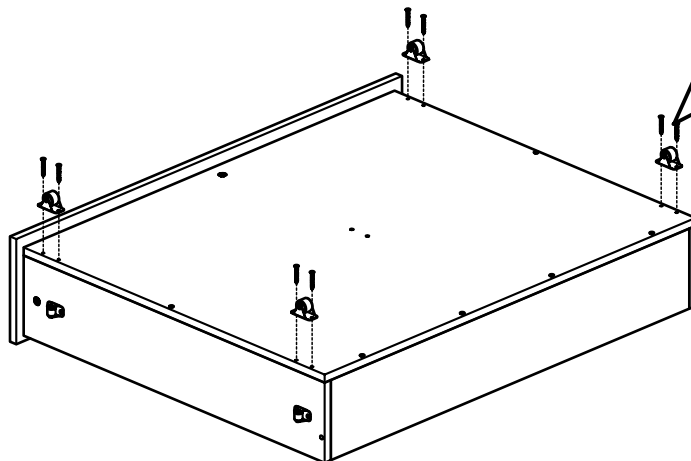
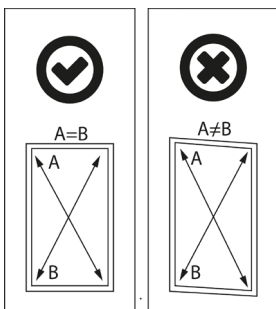

10

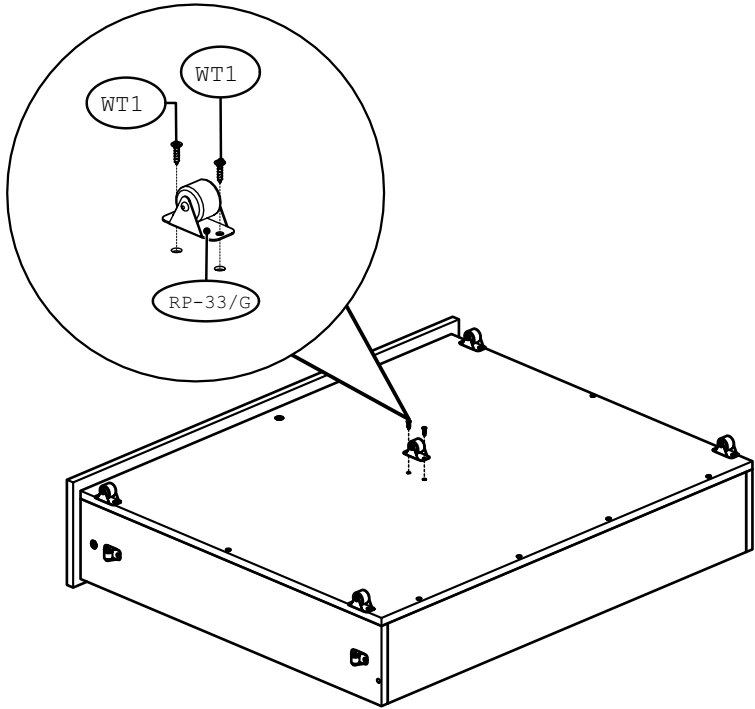
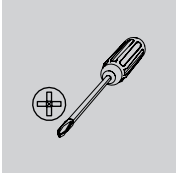
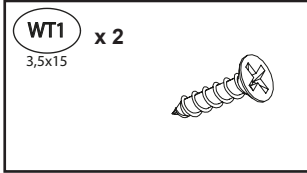
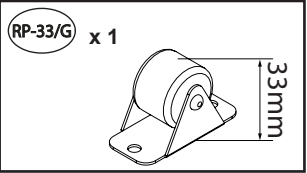

11

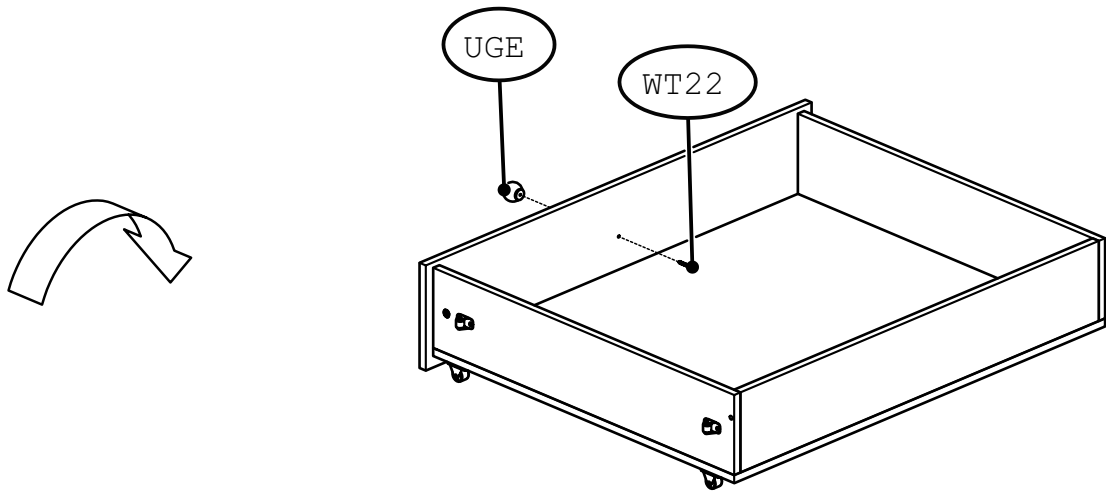
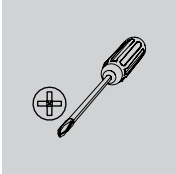
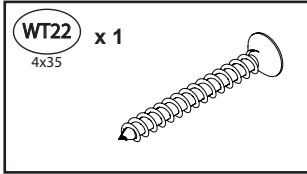
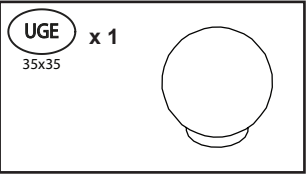

12

L

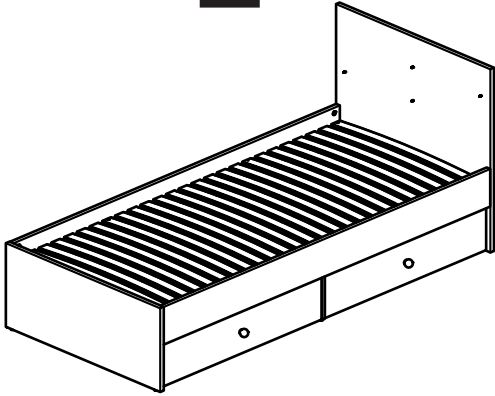

R

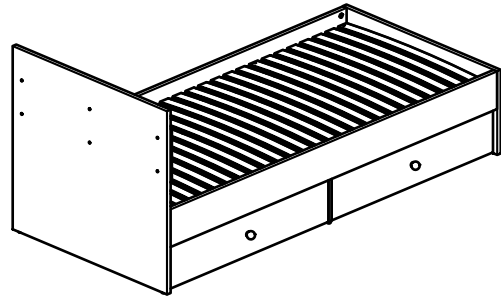

13

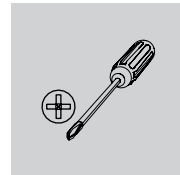
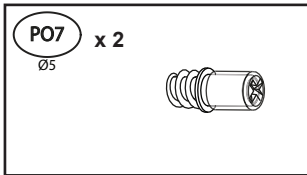

L

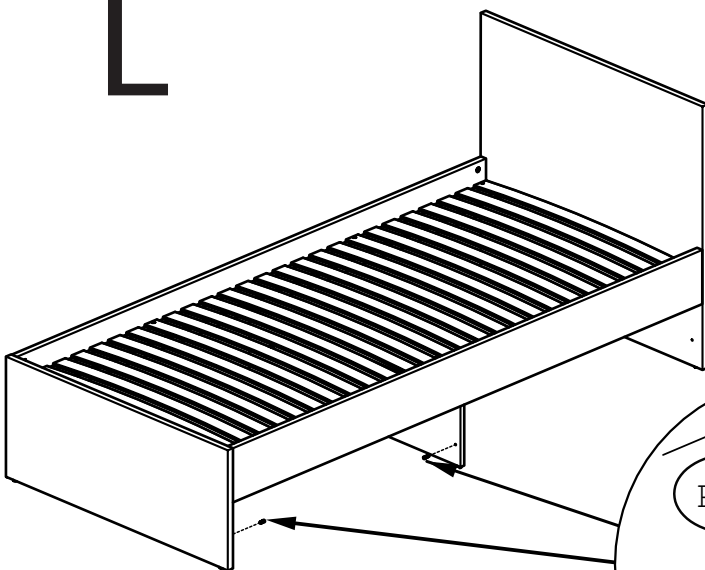

ELMO 20-001  
ELMO 20-002

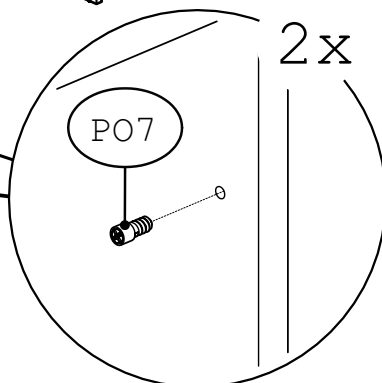
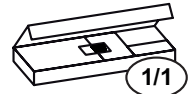

14

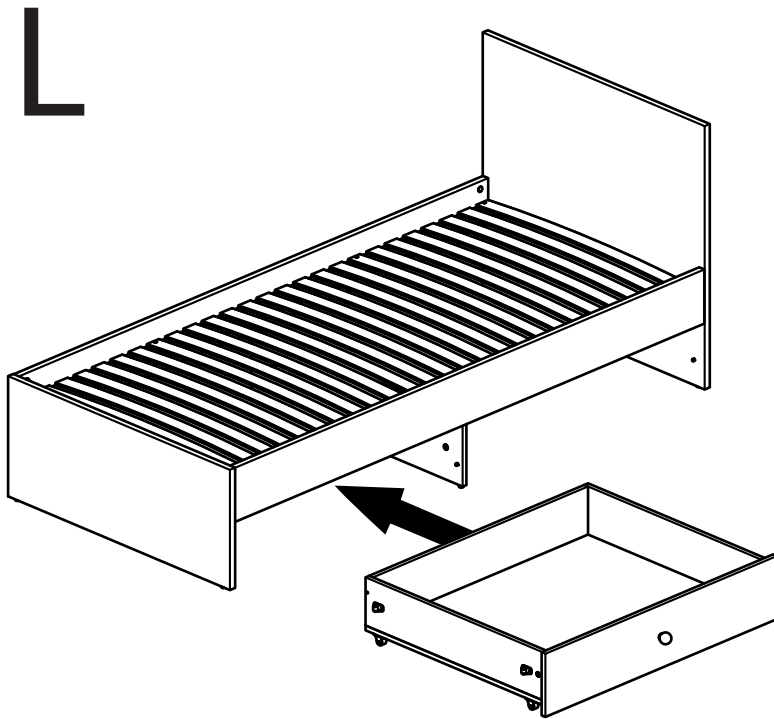

15

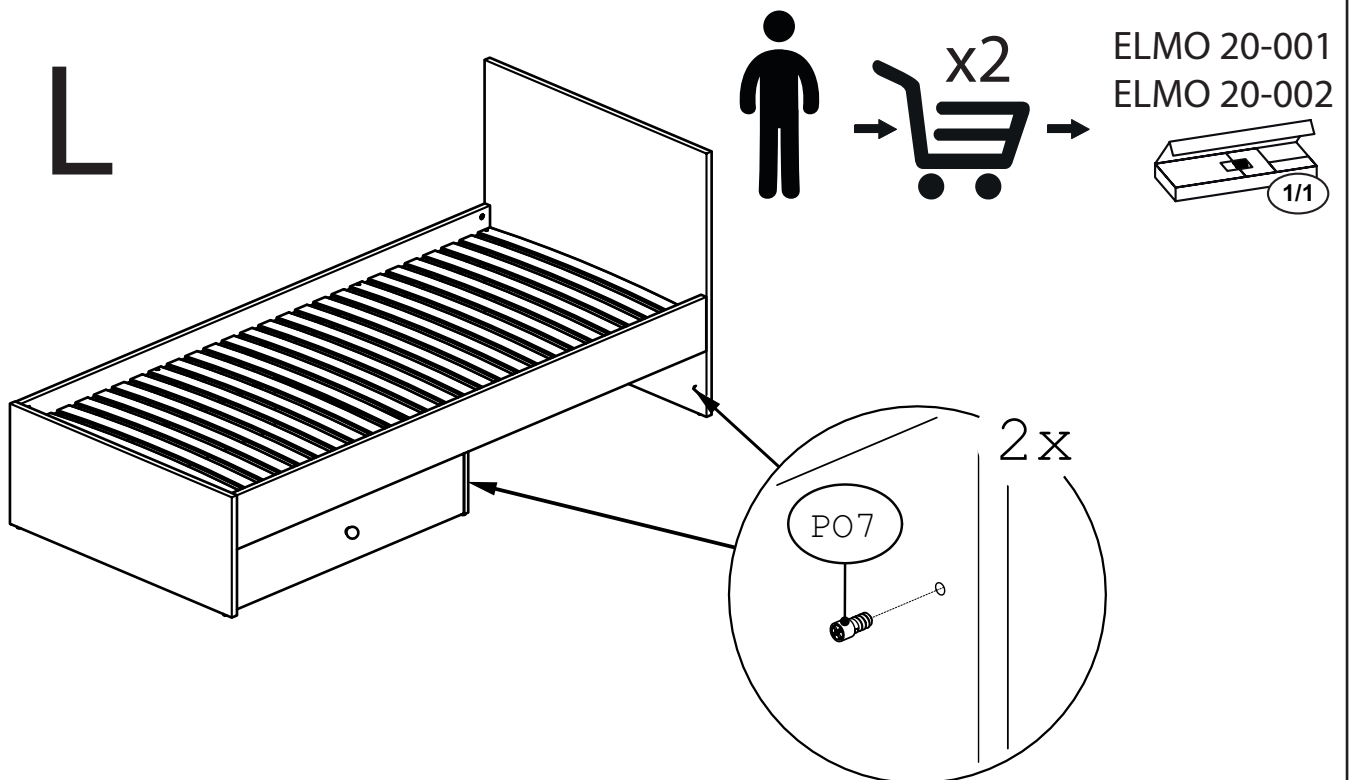

16

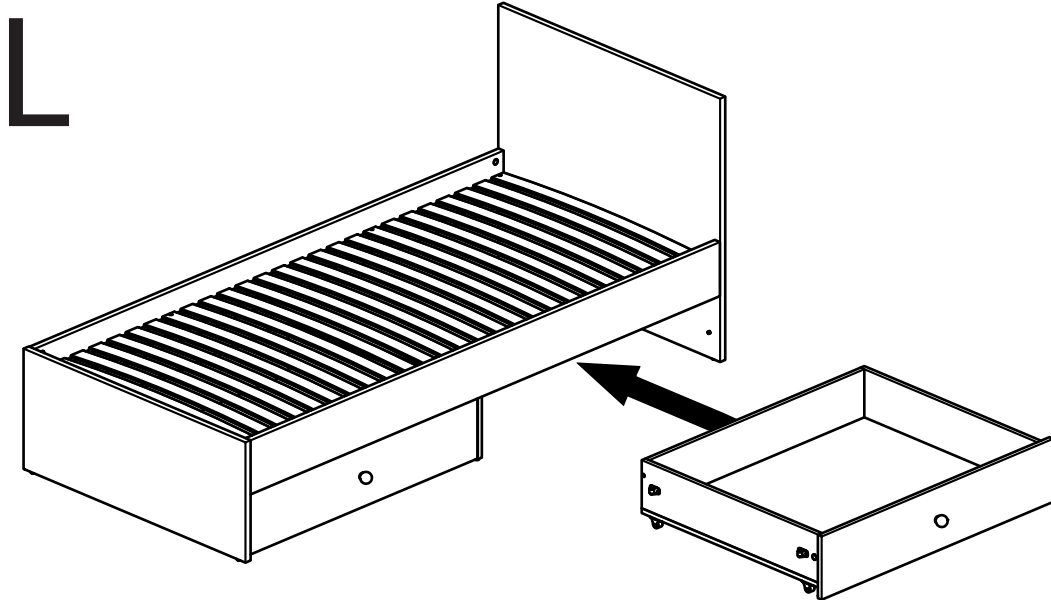

17

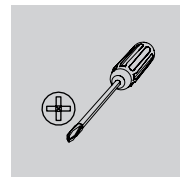
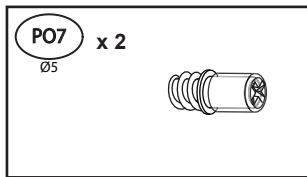

R

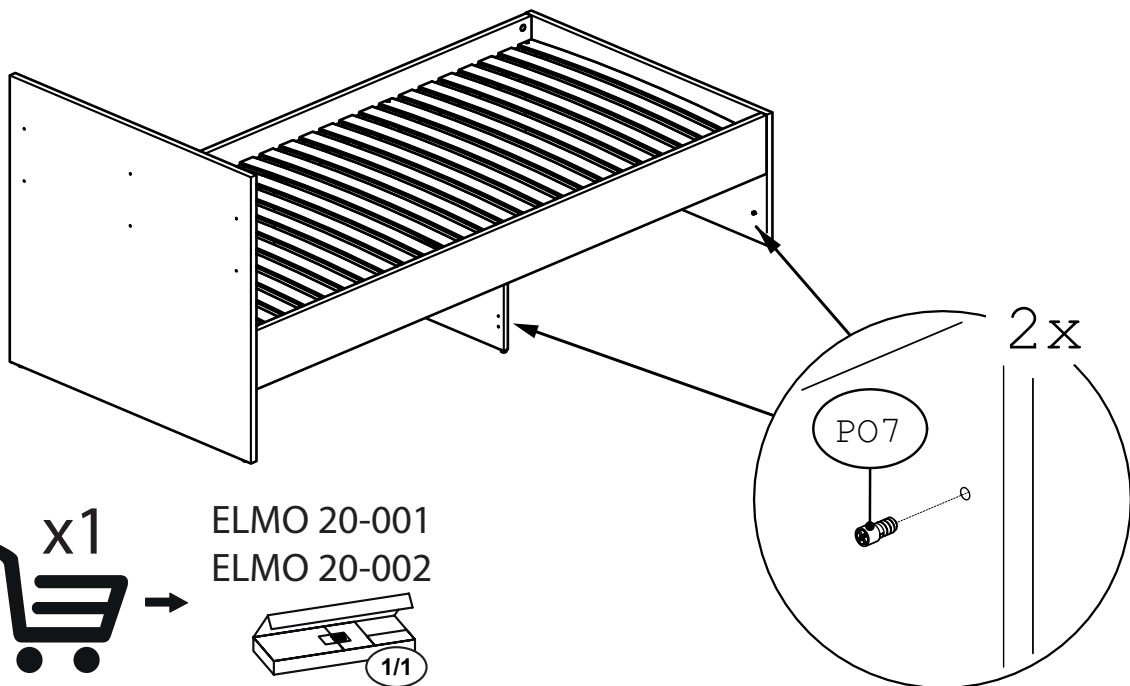

R

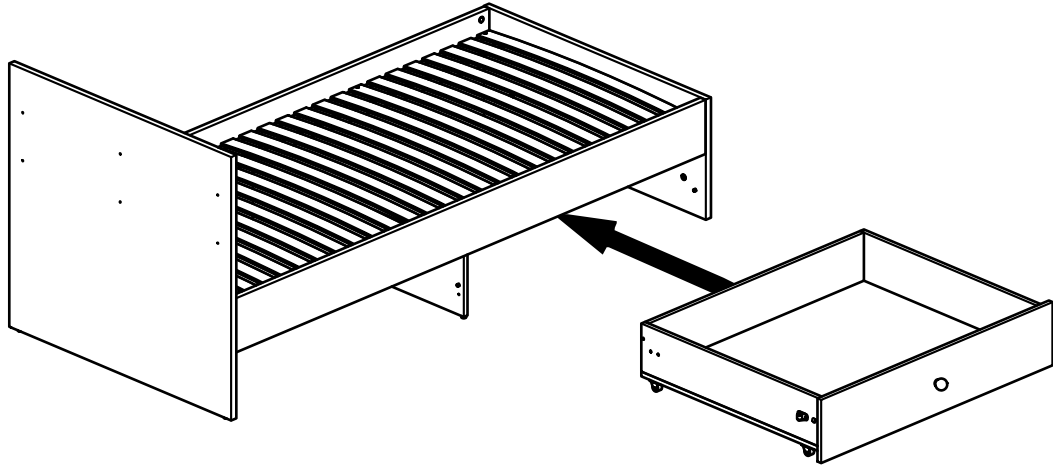

PO7 x 2  
Ø5

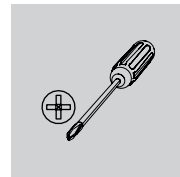
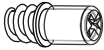

R

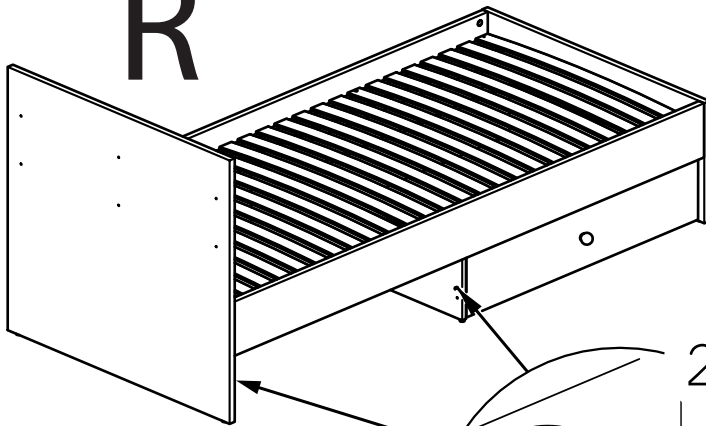

ELMO 20-001  
ELMO 20-002

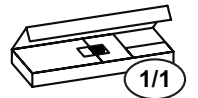

2x

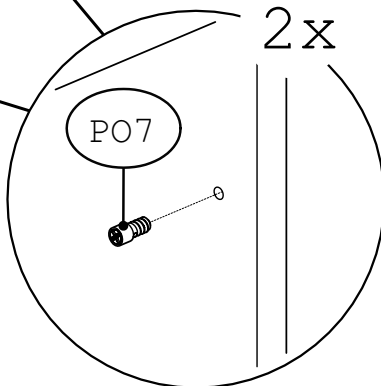

R

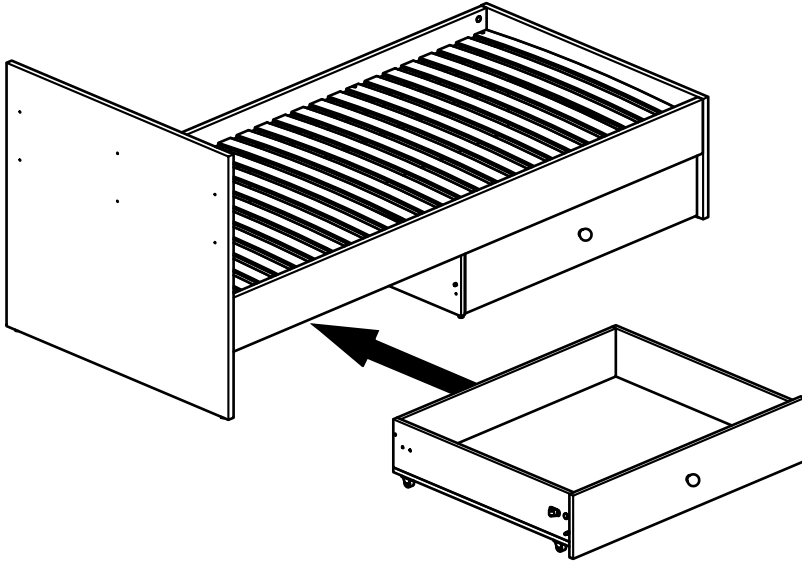



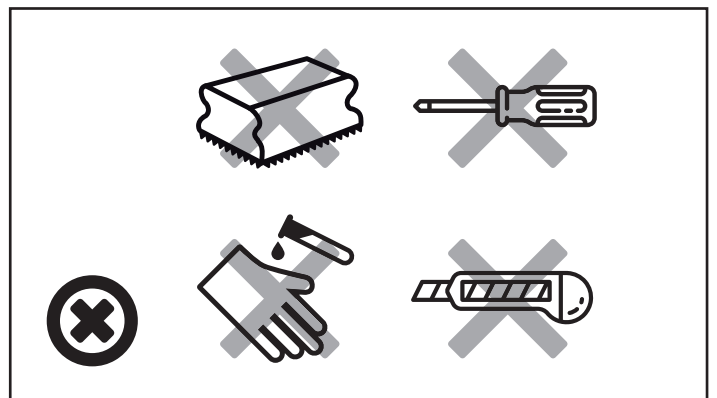
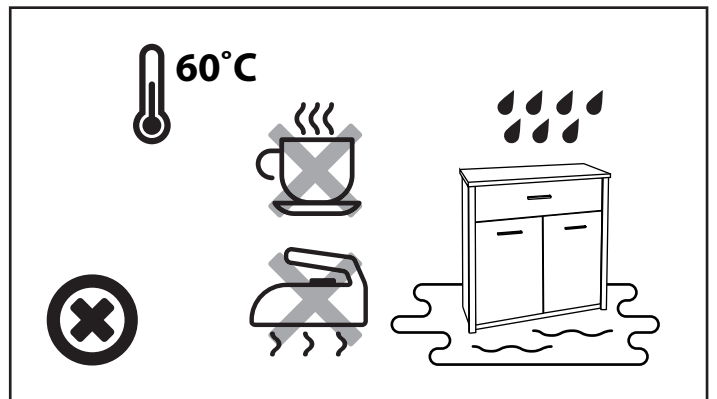
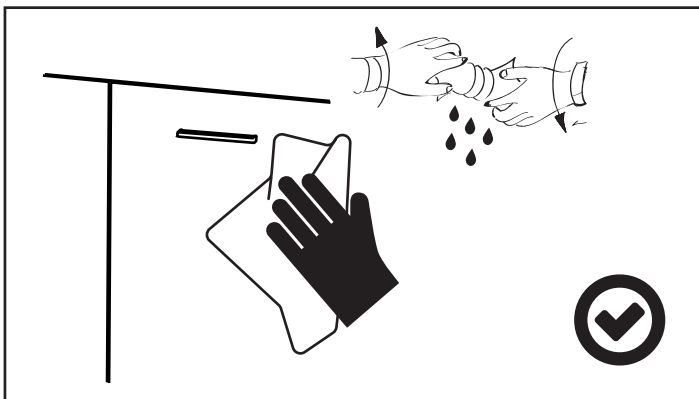
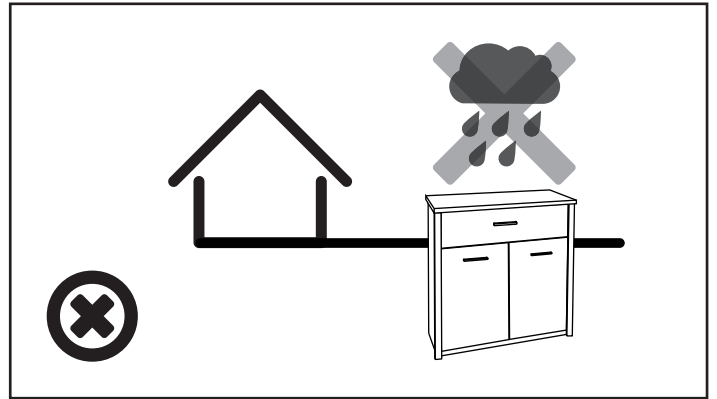
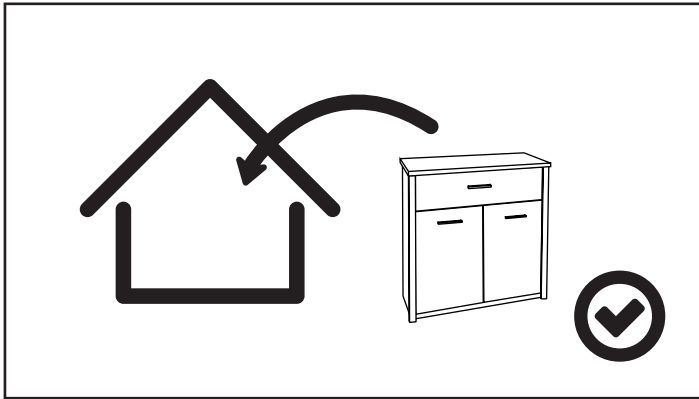
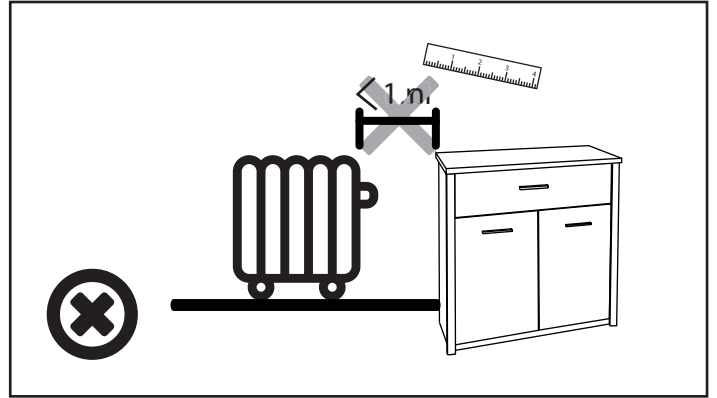
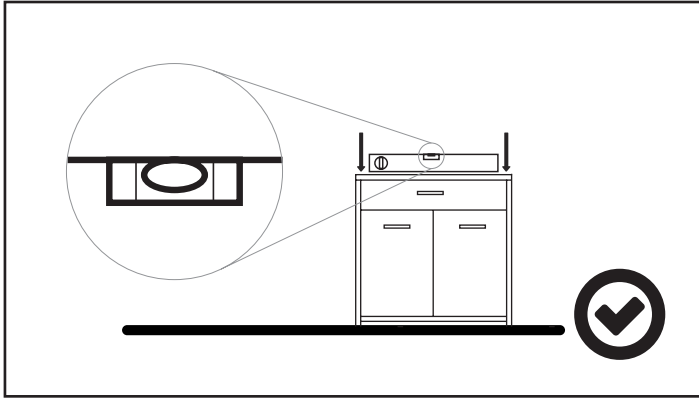







# ZAG 07- 001

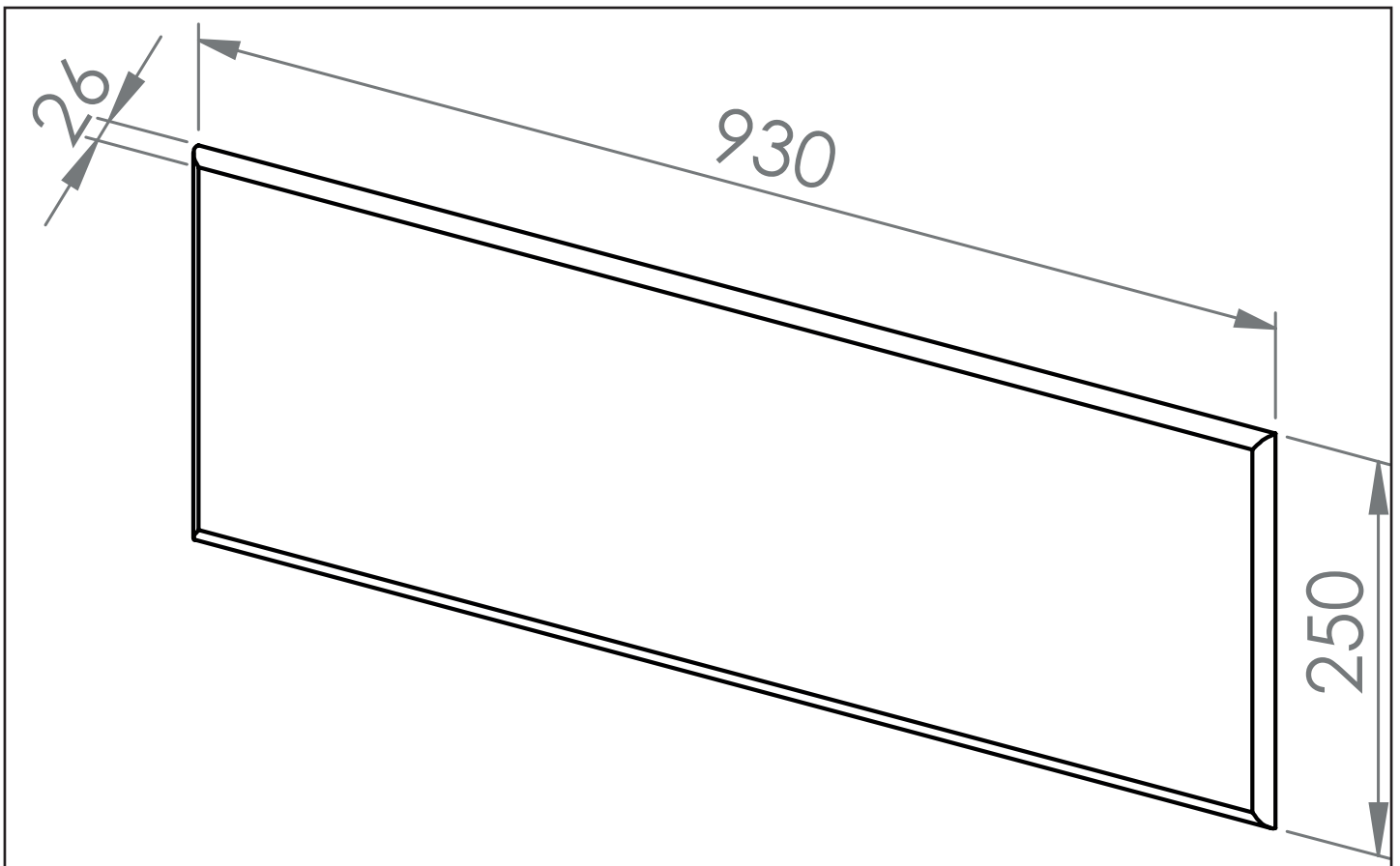
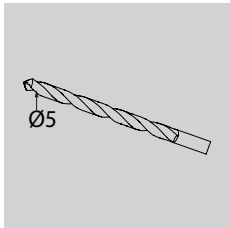
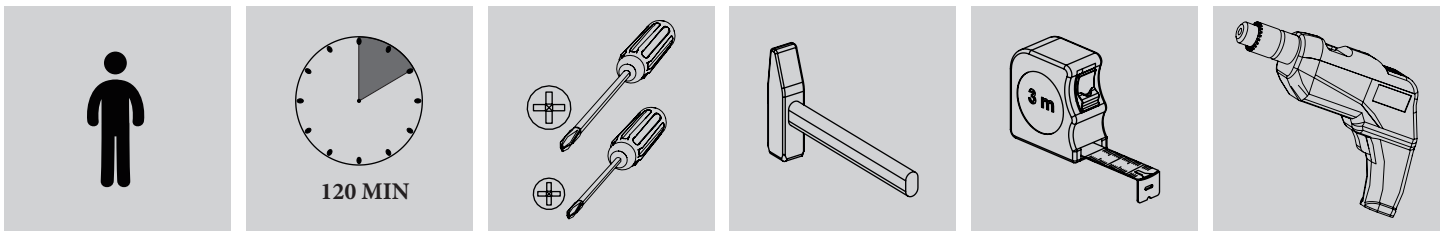

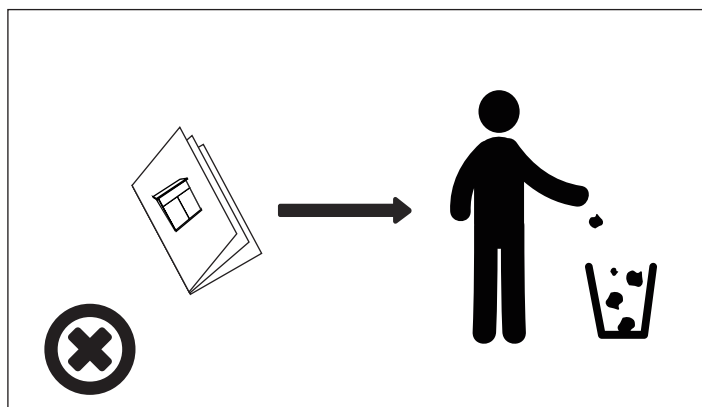
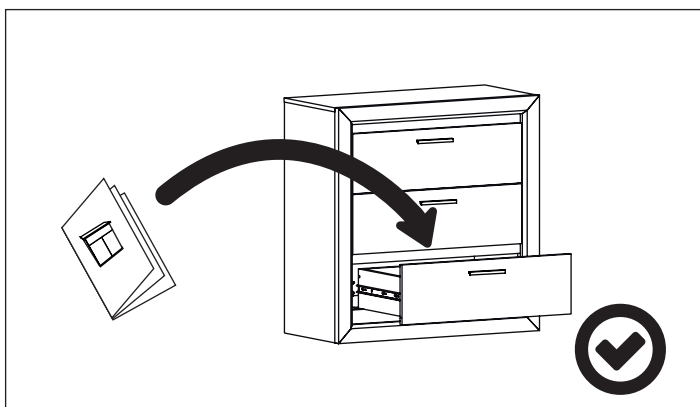
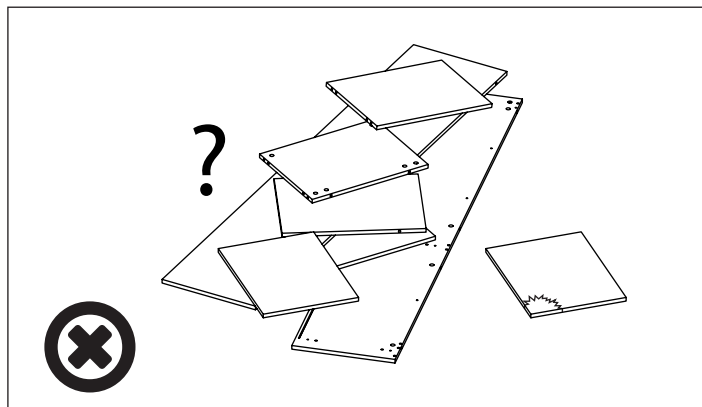
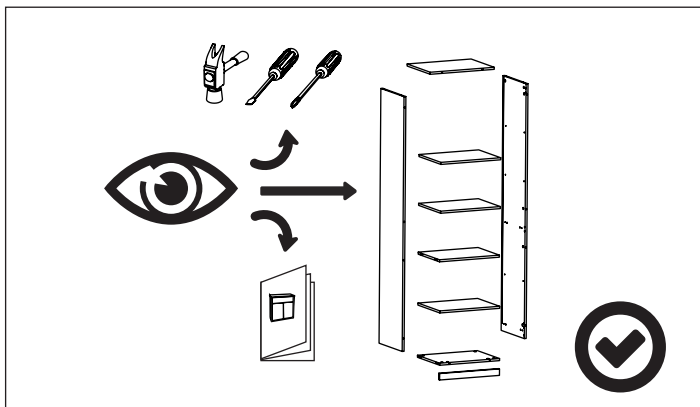
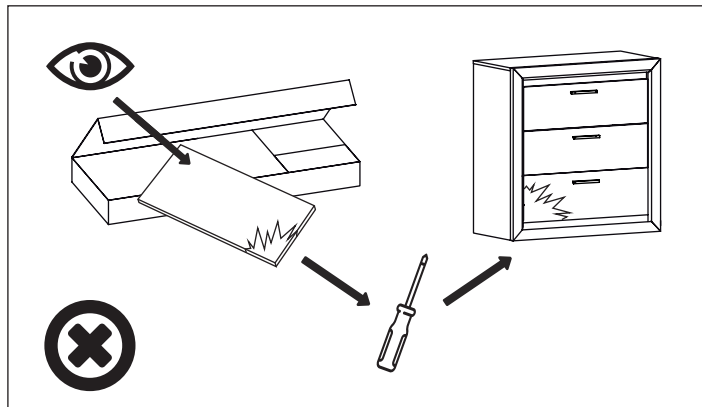
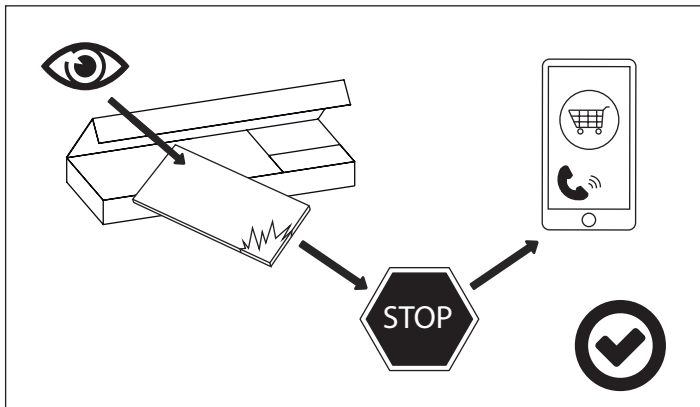
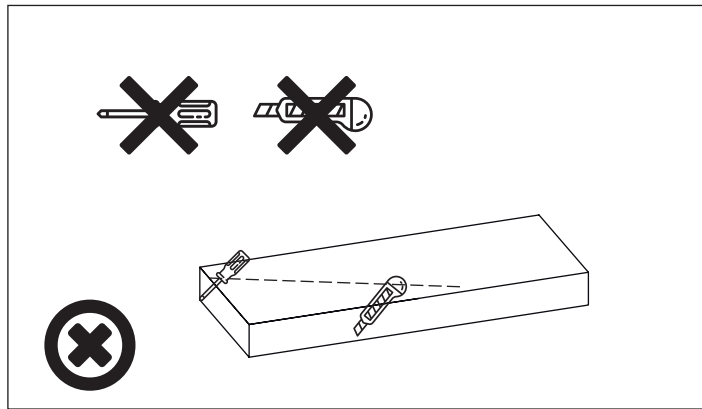
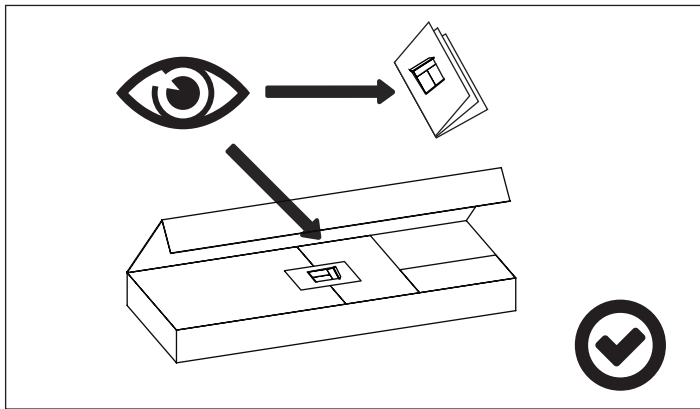

PL - Instrukcja montażu / BG - Сглобяване инструкция / CZ - Montáž instrukce / DE - Montageanleitung / EN - Assembling instruction / ES - Montaje de instrucción / EST - Paigaldusjuhend / FR - Notice de montage / HR - Sastavljanje upute / HU - Szerelési utasítás / I - Istruzioni di montaggio / LT - Montavimo instrukcija / LV - Montāžas instrukcija / NL - Montage instructie / P - Montagem de instrução / RO - Asamblarea de instrucțiuni / RU - Инструкция сборки / S - Montering instruktion / SK - Montáž inštrukcie / SLO - Sestavljanje navodila / SRB - Skлапање инструкцију / TR - Kurulum Talimatları / UKR - Збірка інструкція /

PL - Przed rozpoczęciem zapoznać się z instrukcją montażu / BG - Преди да започнете се отнасят към инструкциите за инсталиране / CZ - Před zahájením naleznete v montážním návodu / DE - Vor die montage, bitte beiliegende anweisungen folgen / EN - Before starting, refer to the assembling advice in annex / ES - Antes de començar referirse a las instrucciones de instalación / EST - Enne käivitamist vaadake paigaldusjuhiseid / FR - Avant de commencer, se reporter aux conseils de montage en annexe / HR - Prije početka pogledajte upute za instalaciju / HU - Megkezdése előtt olvassa el a telepítési utasításokat / I - Avanti di cominciare, riportate agli consigli di montaggio / LT - Prieš pradant kreiptis į montavimo instrukcija / LV - Pirms sākt montāžu, iepazīties ar instrukciju / NL - Voordat u begint Zie de installatie-instructies / P - Antes de começar a consultar as instruções de instalação / RO - Înainte de a începe să consultați instrucțiunile de instalare / RU - Перед началом обратитесь к инструкции по установке / S - Innan du börjar se Installationsanvisningen / SK - Pred začatím nájdete v montážnom návode / SLO - Pred začetkom glejte navodila za namestitvev / SRB - Пре почетка погледајте упутства за инсталацију / TR - Kurulumla başlanmadan önce, montaj talimatnamesini sirasiyla takip edin. / UKR - Перед початком зверніться до інструкції з установки /





	CODE				
1	ZAG 07-001	930	250	1	1/1
2					
3					
4					
5					
6					
7					
8					
9					
10					
11					
12					
13					
14					
15					

	CODE				
16					
17					
18					
19					
20					
21					
22					
23					
24					
25					
26					
27					
28					
29					
30					

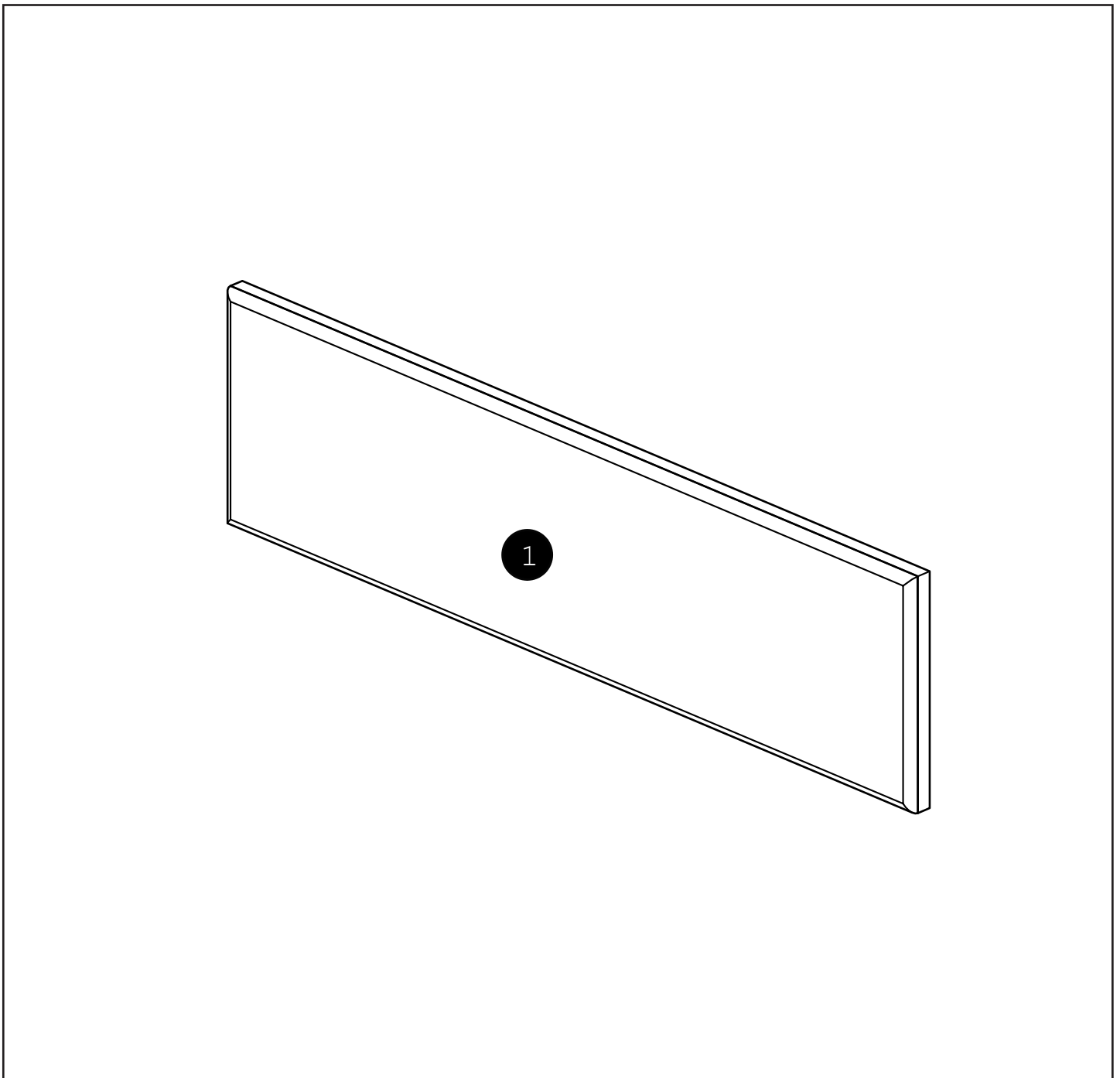

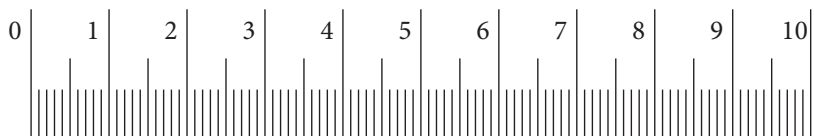
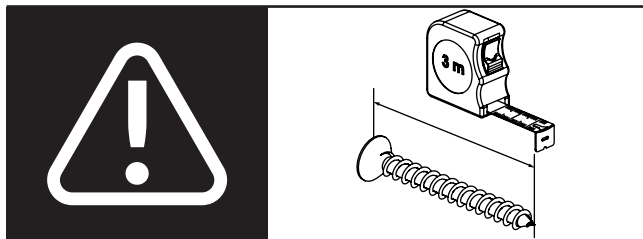
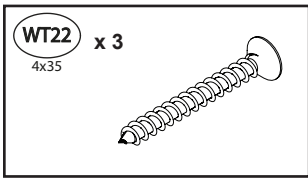

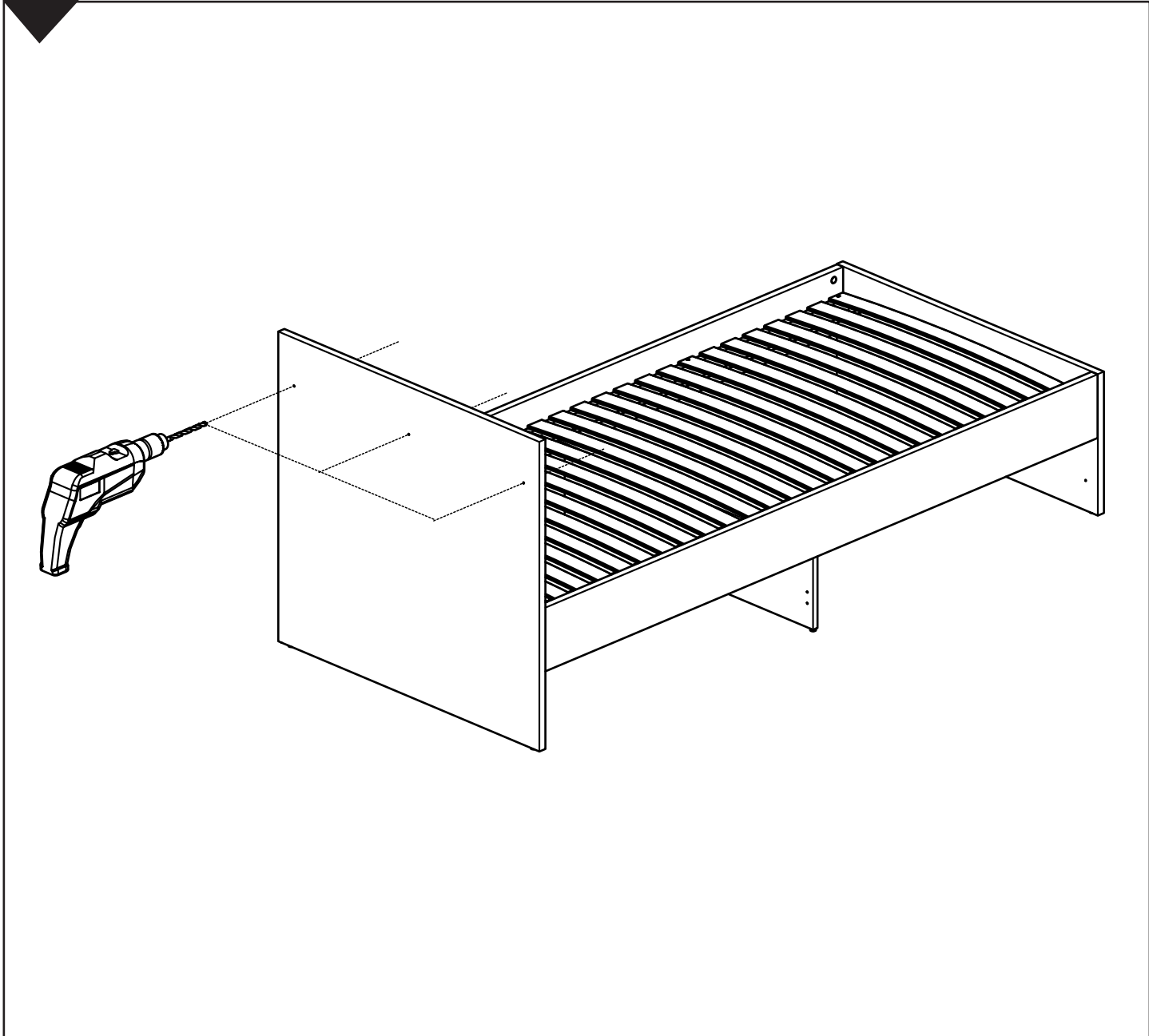
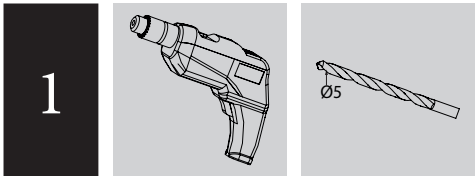
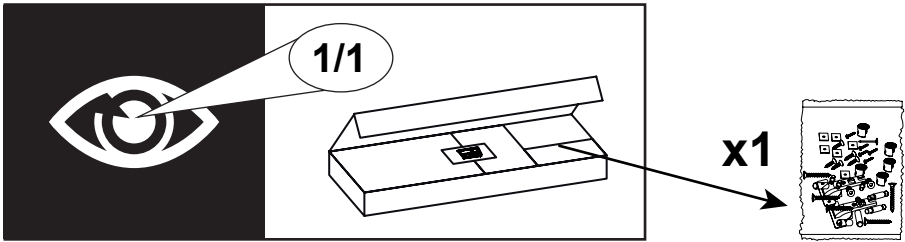
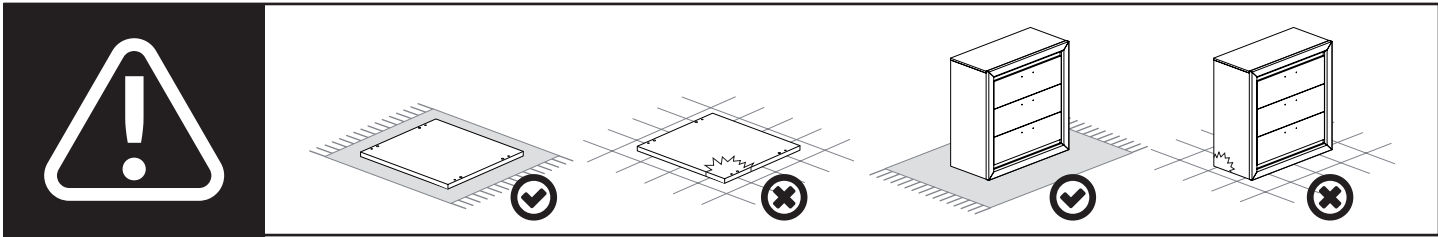

2

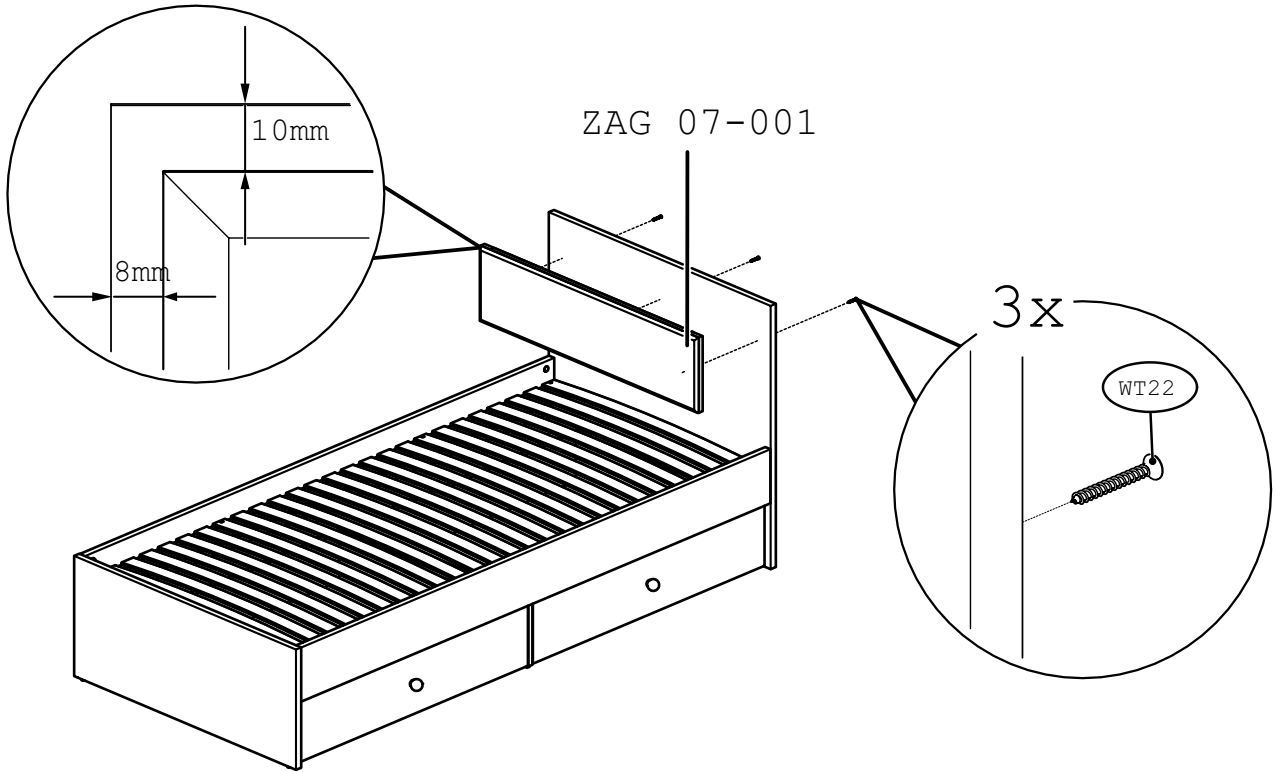
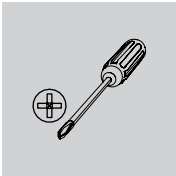
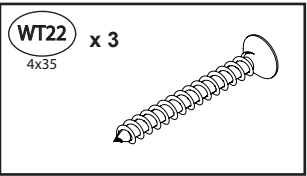

3

