

LK 111 S 120,140,160,180,200 D 200

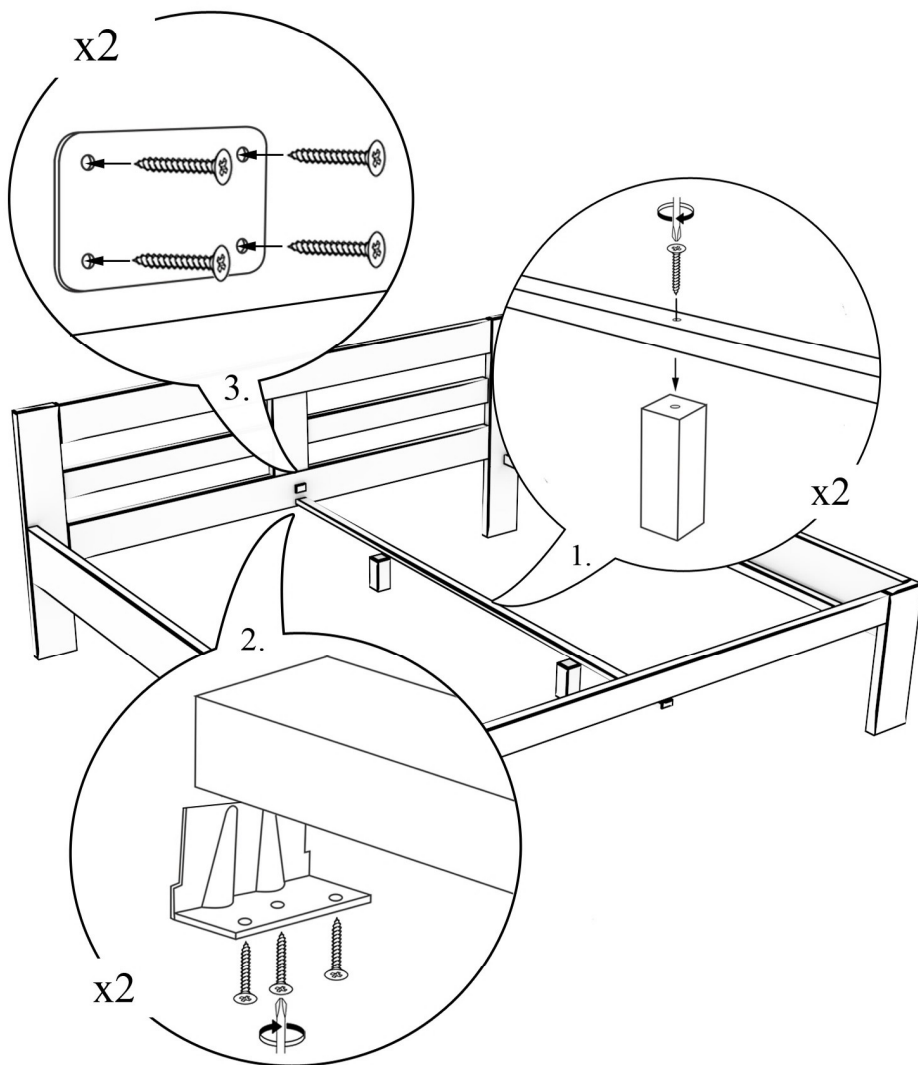

PL : Dla wzmocnienia konstrukcji zaleca się przykręcenie stelaża do ramy łóżka
 SK : Pre posiljenje konstrukcije, odporučamo rám roštu priskrutkovati na rám posteje
 EN : To strengthen the bed construction it is recommended to screw
 the slat under the mattress to frame of the bed
 CS : Prt posiljenje strukturu, doporučuje se šroub rámeček na rám posteje

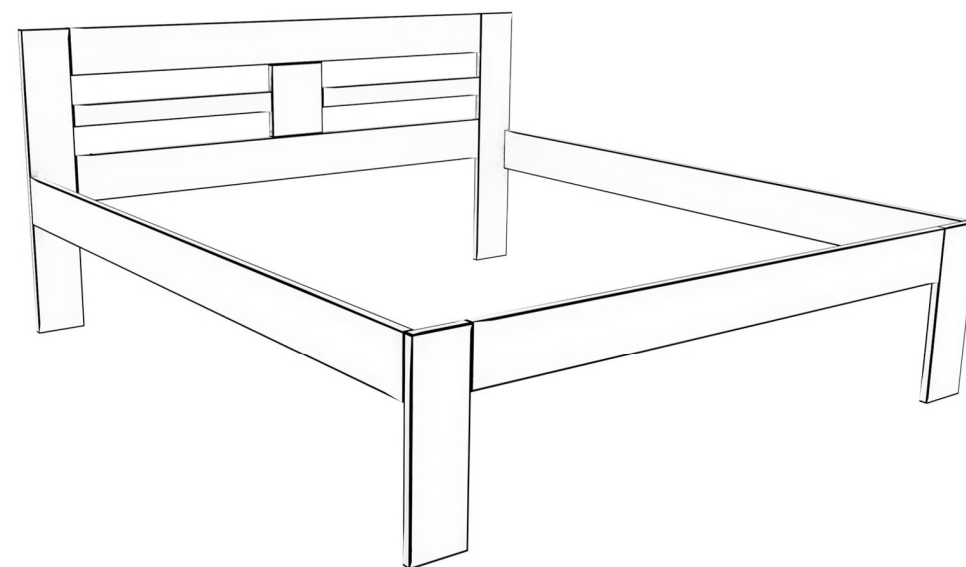

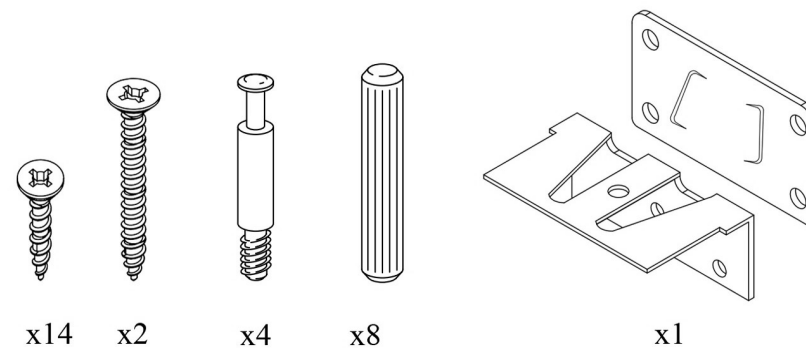
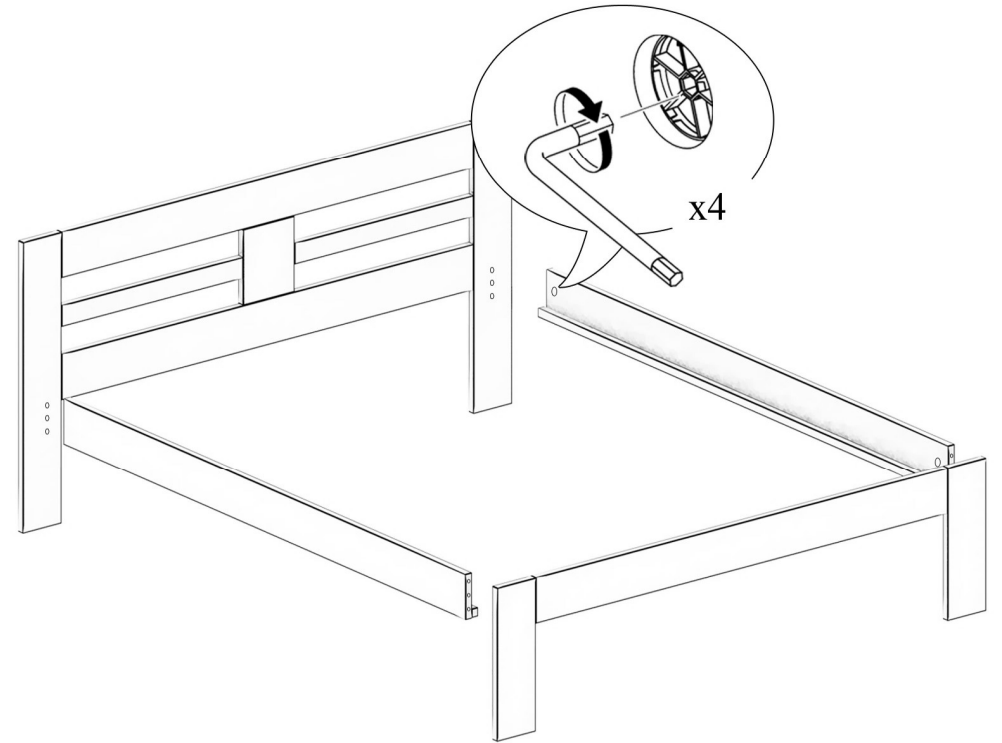
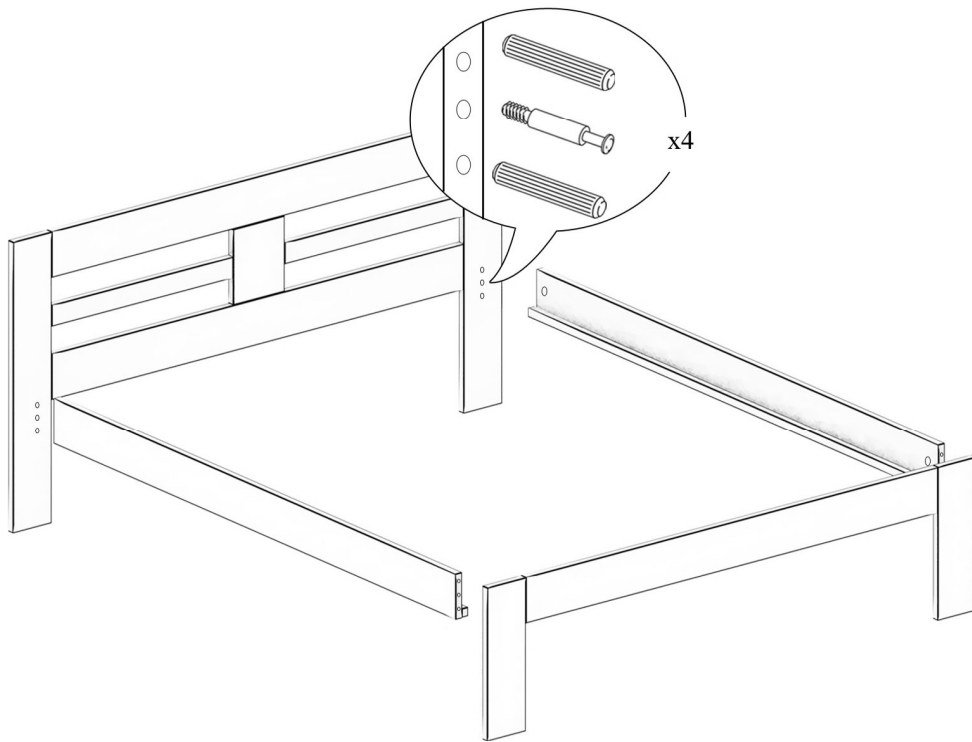

LK 160 S 80,90,100 D 200

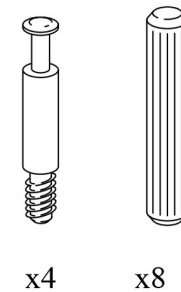
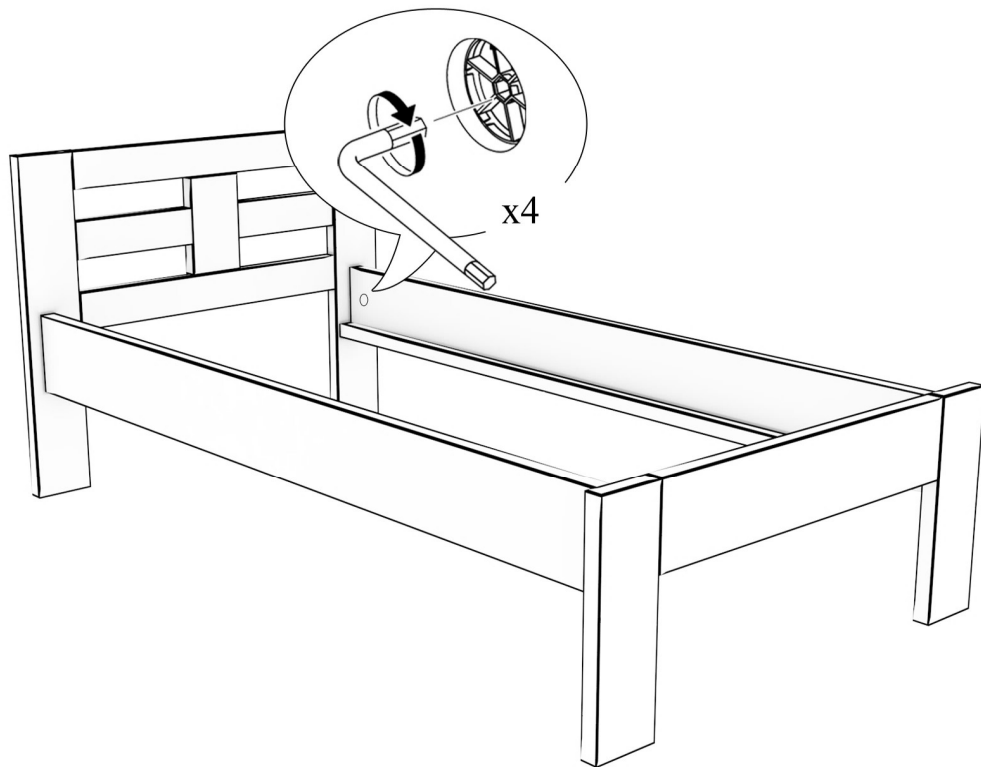

PL : Dla wzmocnienia konstrukcji zaleca się przykręcenie stelaża do ramy łóżka
SK : Pre posilnenie konštrukcie, odporúčame rámov roštu priskrutkovať na rámy posteľe
EN : To strengthen the bed construction it is recommended to screw the slat under the mattress to frame of the bed
CS : Pro posilnenie struktúry, doporučuje sa šroub rámeček na rámy posteľe

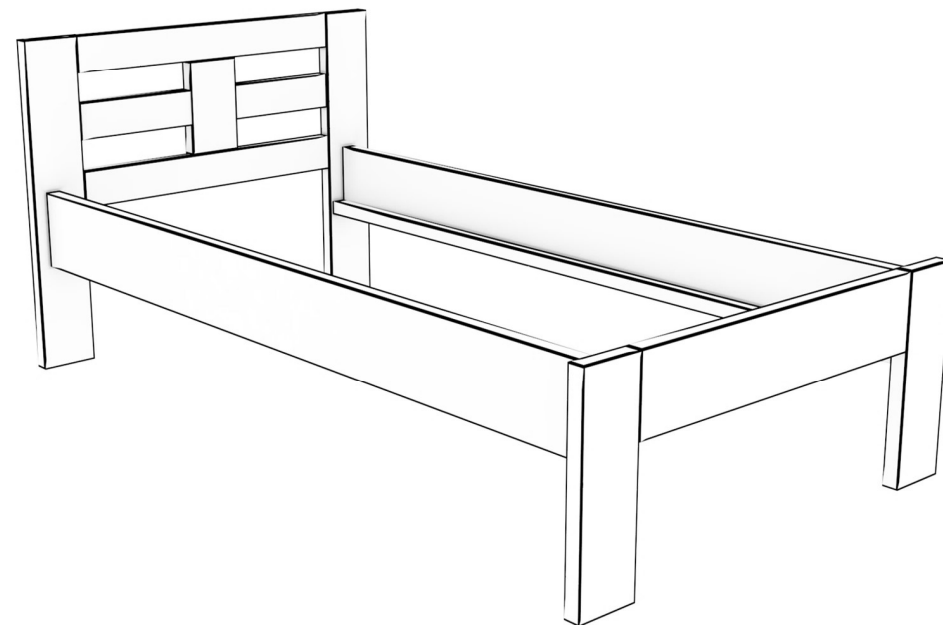



LK 176 S 80, 90, 100, 120, 140, 160, 180, 200 D200

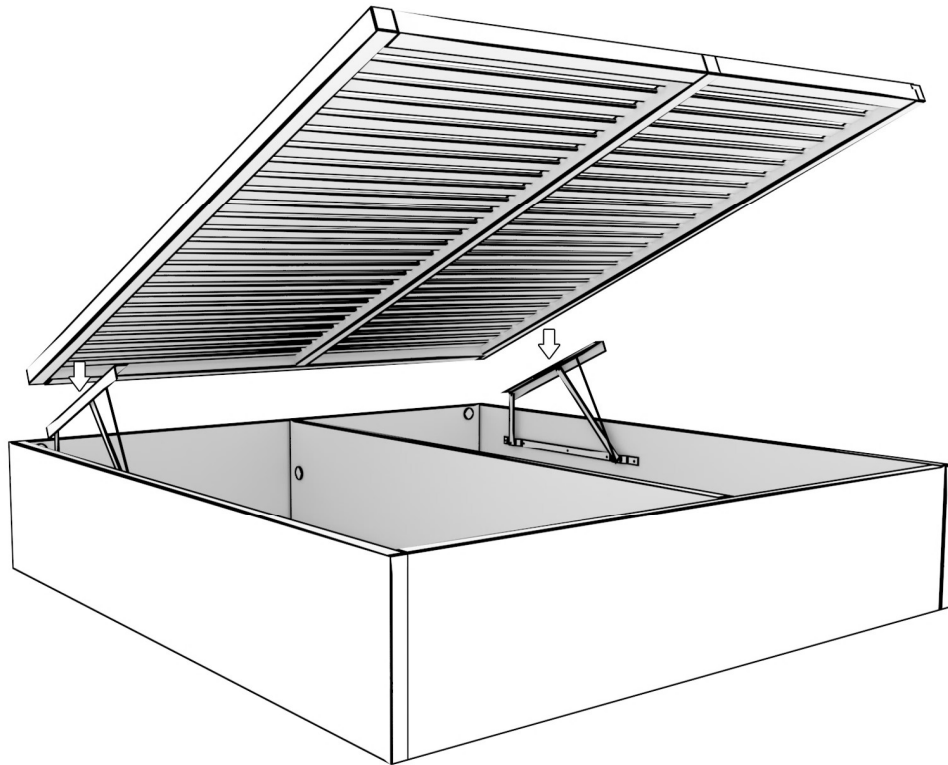

PL : Dla wzmocnienia konstrukcji zaleca się przykręcenie stelaża do ramy łóżka
SK : Pre posilnenie konštrukcie, odporúčame rám roštu priskrutkovať na rám posteľe
EN : To strengthen the bed construction it is recommended to screw the slat under the mattress to frame of the bed
CS : Pro posílení strukturu, doporučuje se šroub rámeček na rám postele



x4

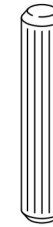

x8

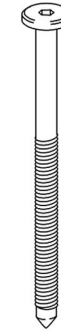

x4

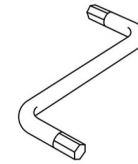

x1

