

# FLY TYP-51

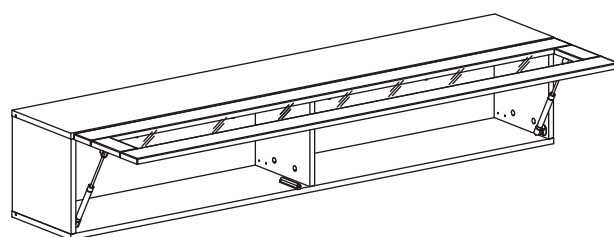

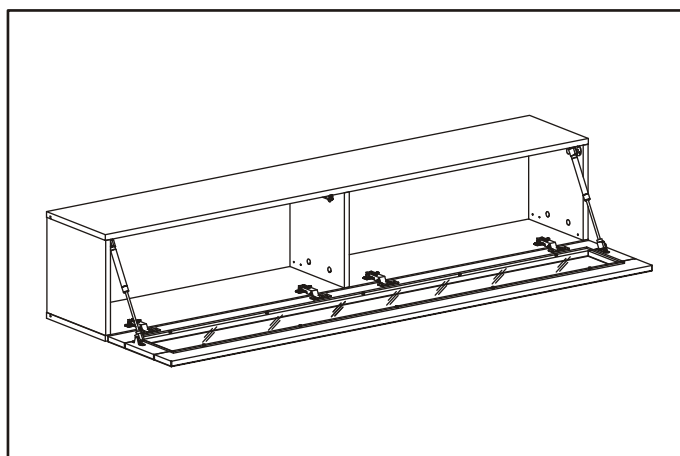

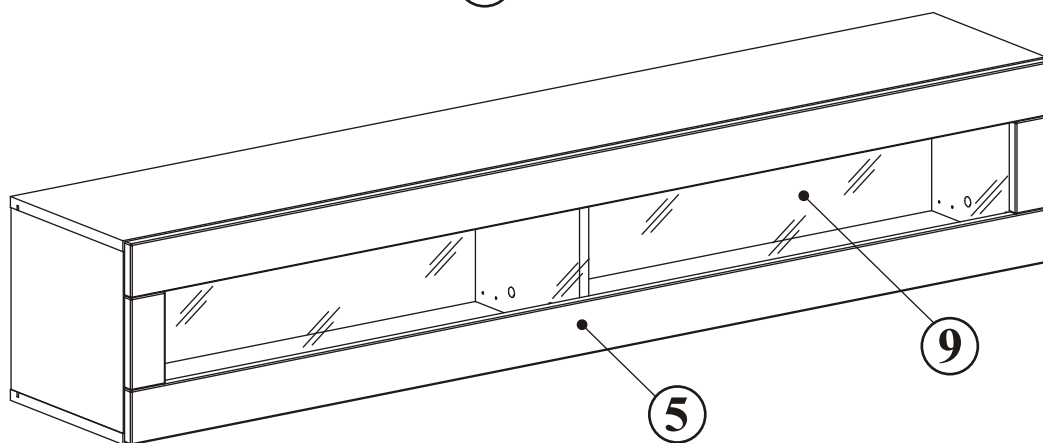

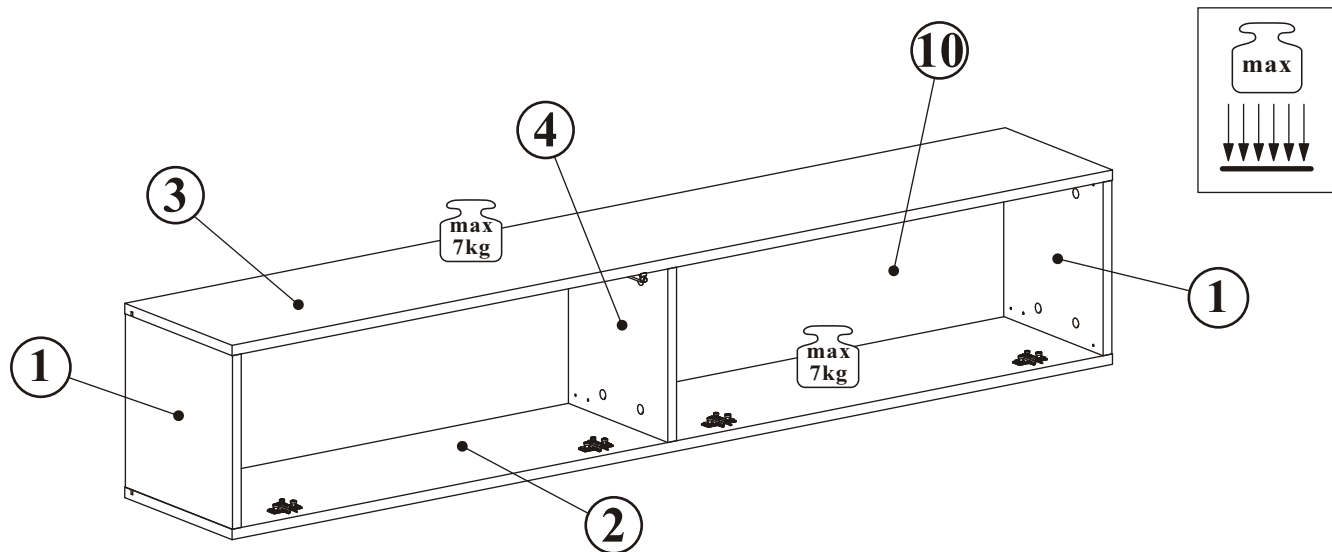
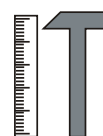
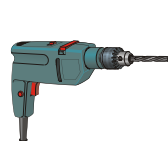

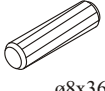
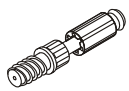

NO	Dim.		Col.-No	Qty
1	268	274	1	2
2	1602	274	1	1
3	1602	274	1	1
4	268	244	1	1
10	1580	280	1	1
5	1596	296	1	1
9	1496	176	1	1

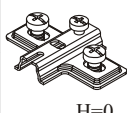
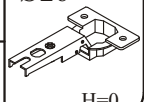

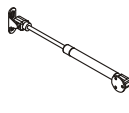
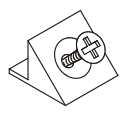
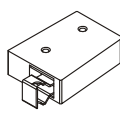
90 min

FLY TYP-51

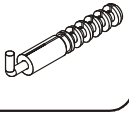
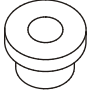
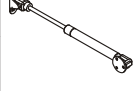
A1 x12  ø8x36	B4 x12 	B5 x12  ø15x12	G5 x12 	E2 x4  H=0	E1 x4  H=0
T1 x1 	BO1 x2 	S1 x12 	ZR1 x3 	D6 x6  USØ3,5x30	D10 x20  USØ3,5x13
UP13 x12  UPØ3x16	G2 x1 	KR2 x3 	P2 x10 	BP1 x2 	

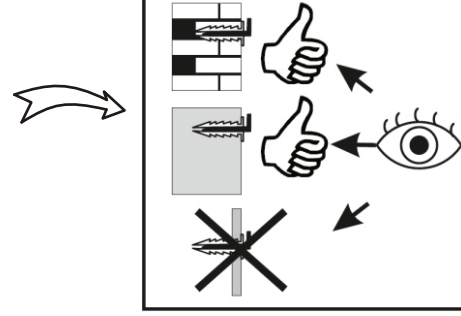
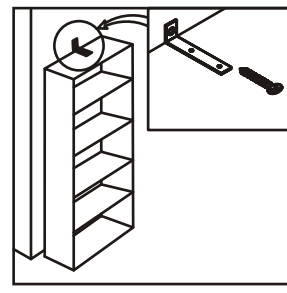
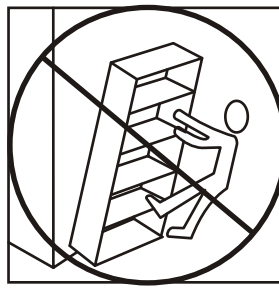
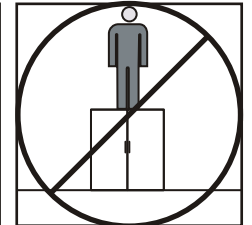
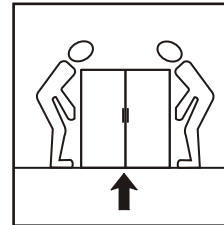
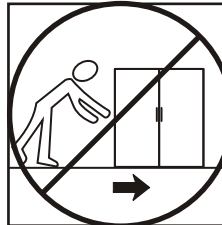
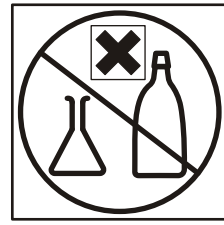
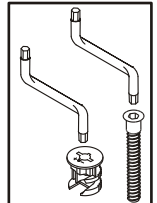
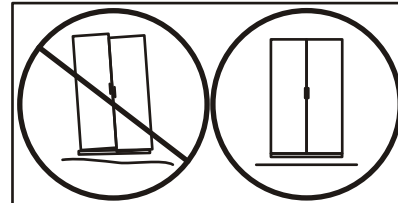
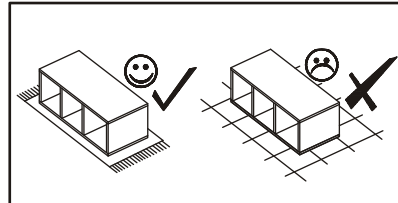
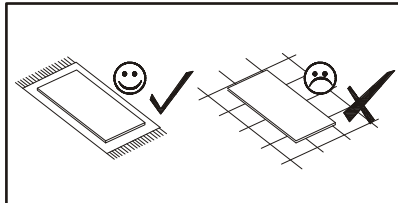
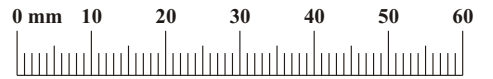

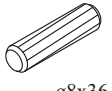
B5		A1	
x12	ø15x12	x12	ø8x36

1

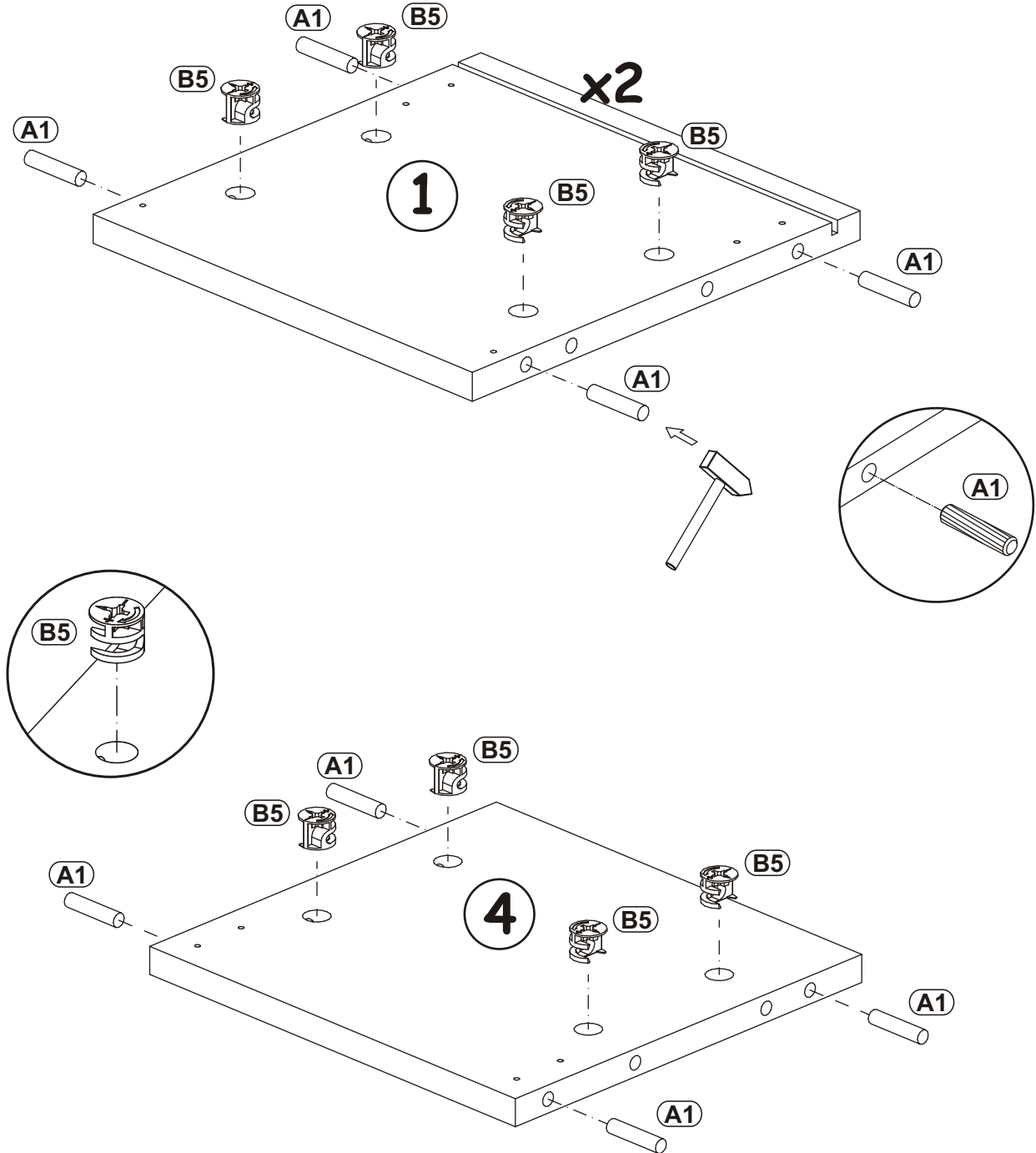

FLY TYP-51

2

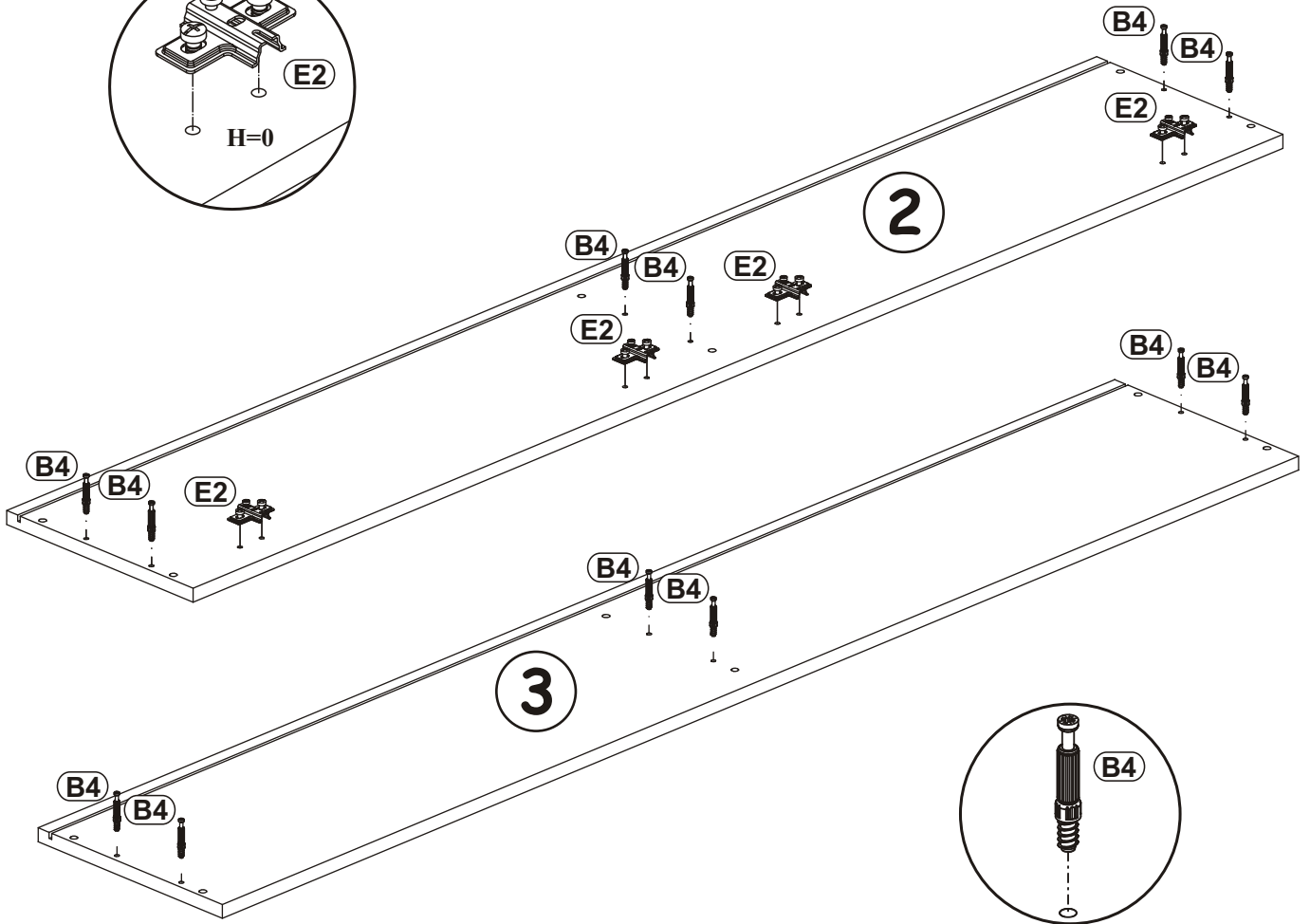
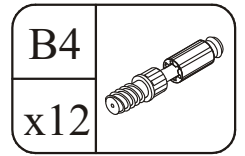
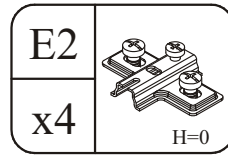
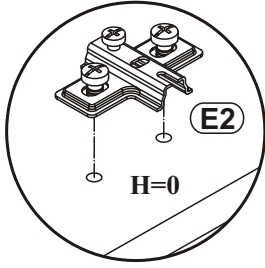

3

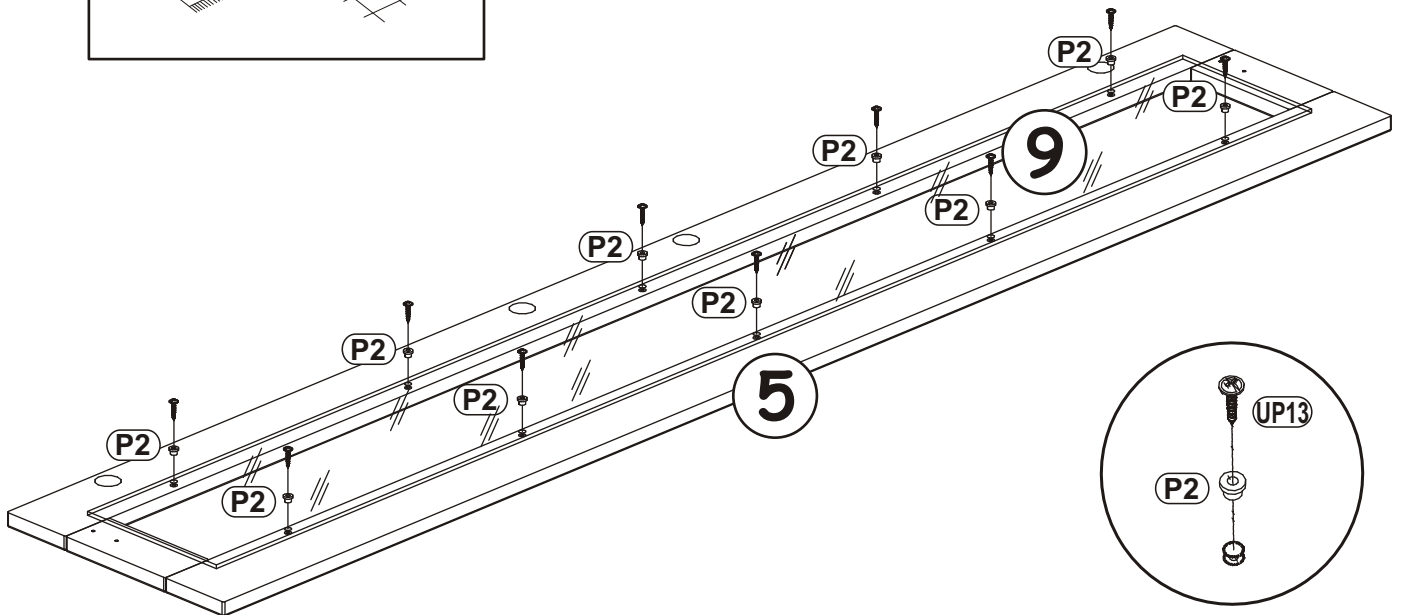
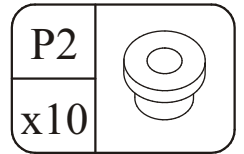
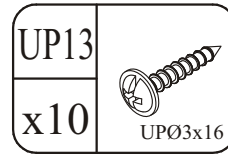
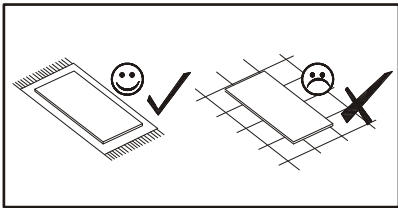

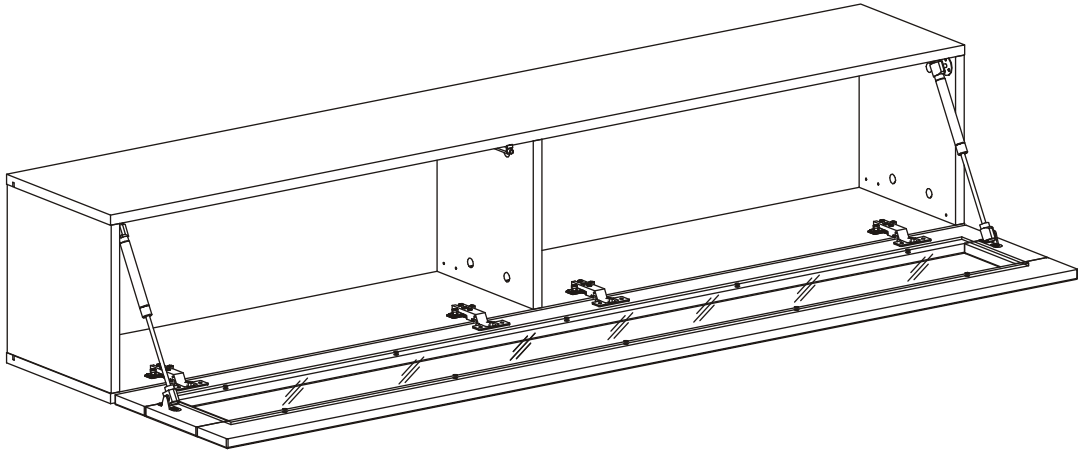

**4 - 11**

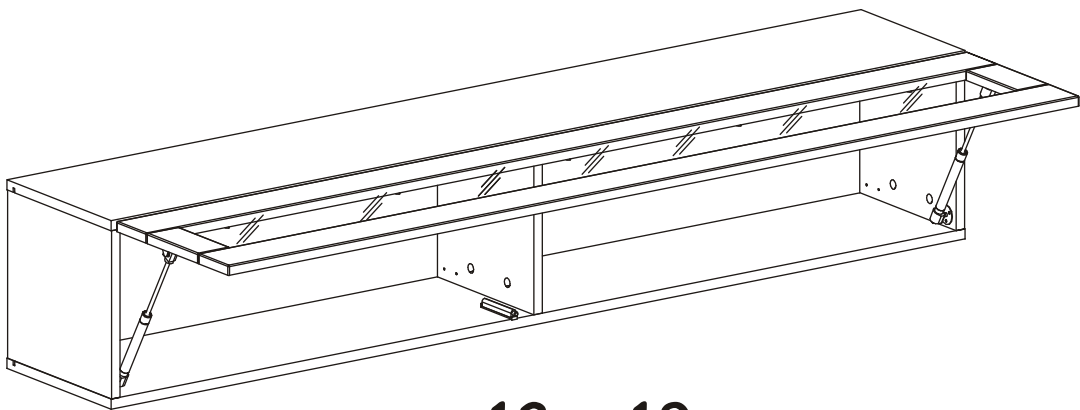

**12 - 19**

FLY TYP-51

4

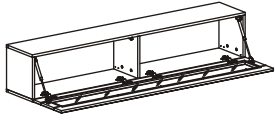
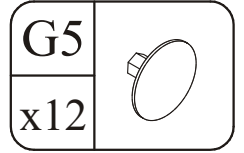

a)

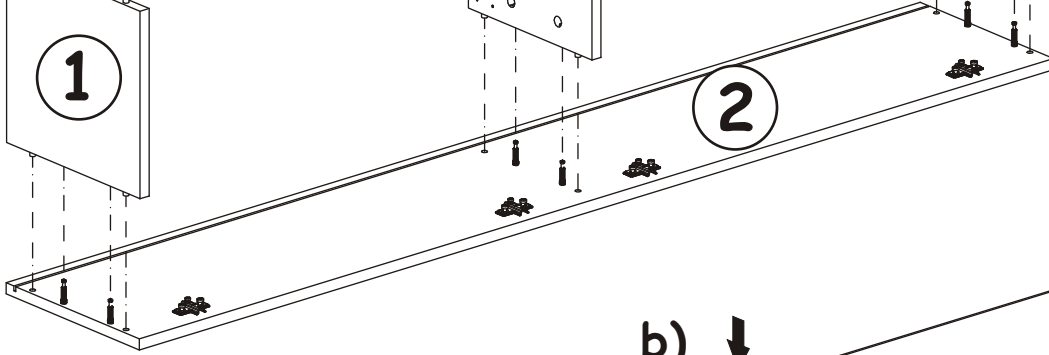
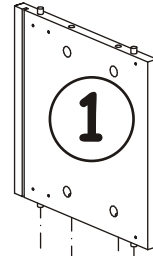
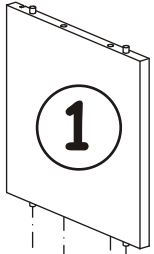

b) ↓

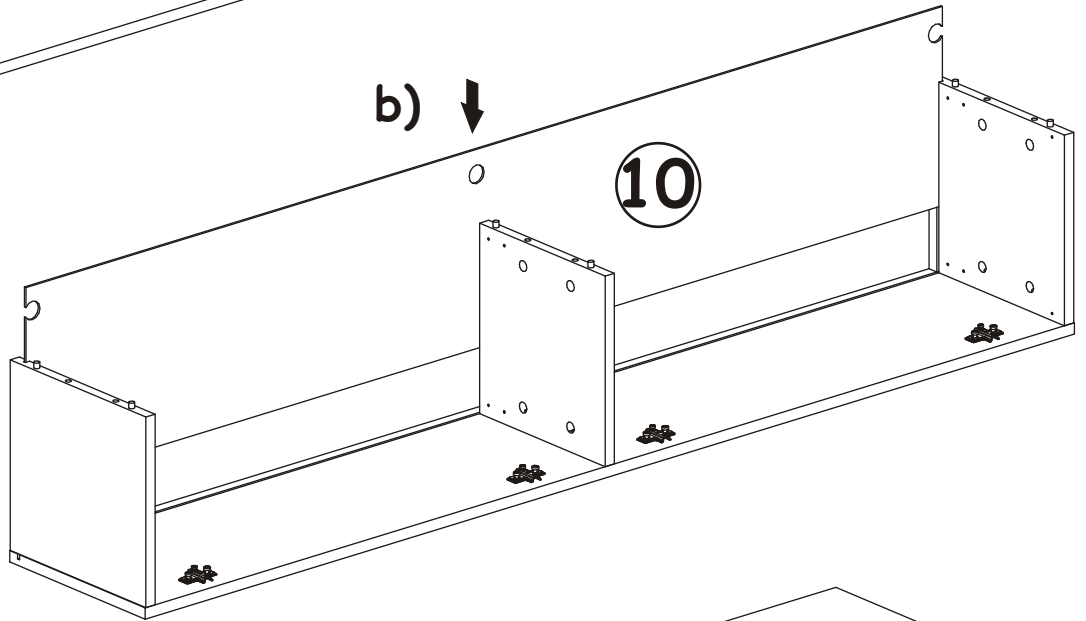
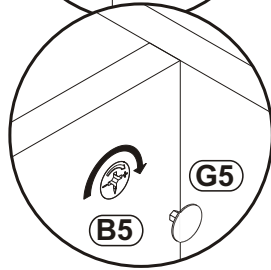
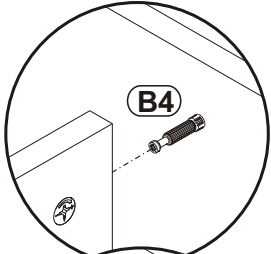

c)

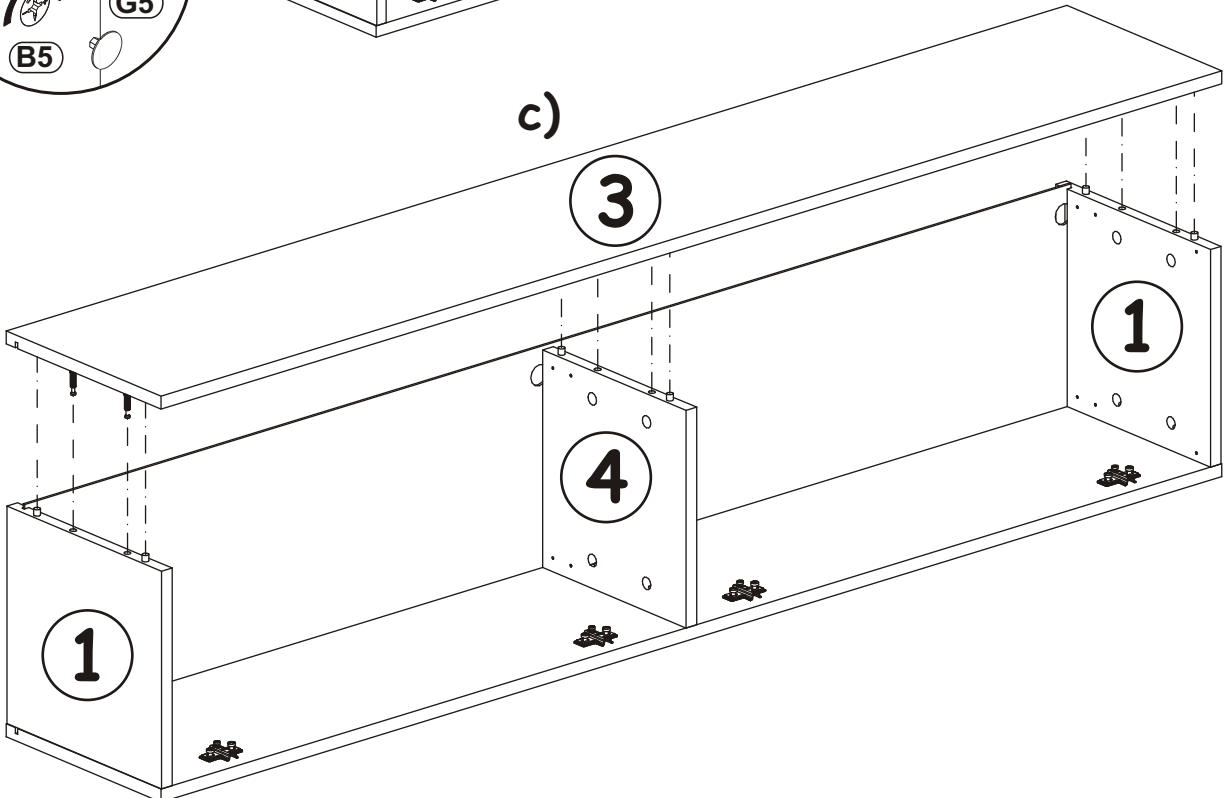

FLY TYP-51

5

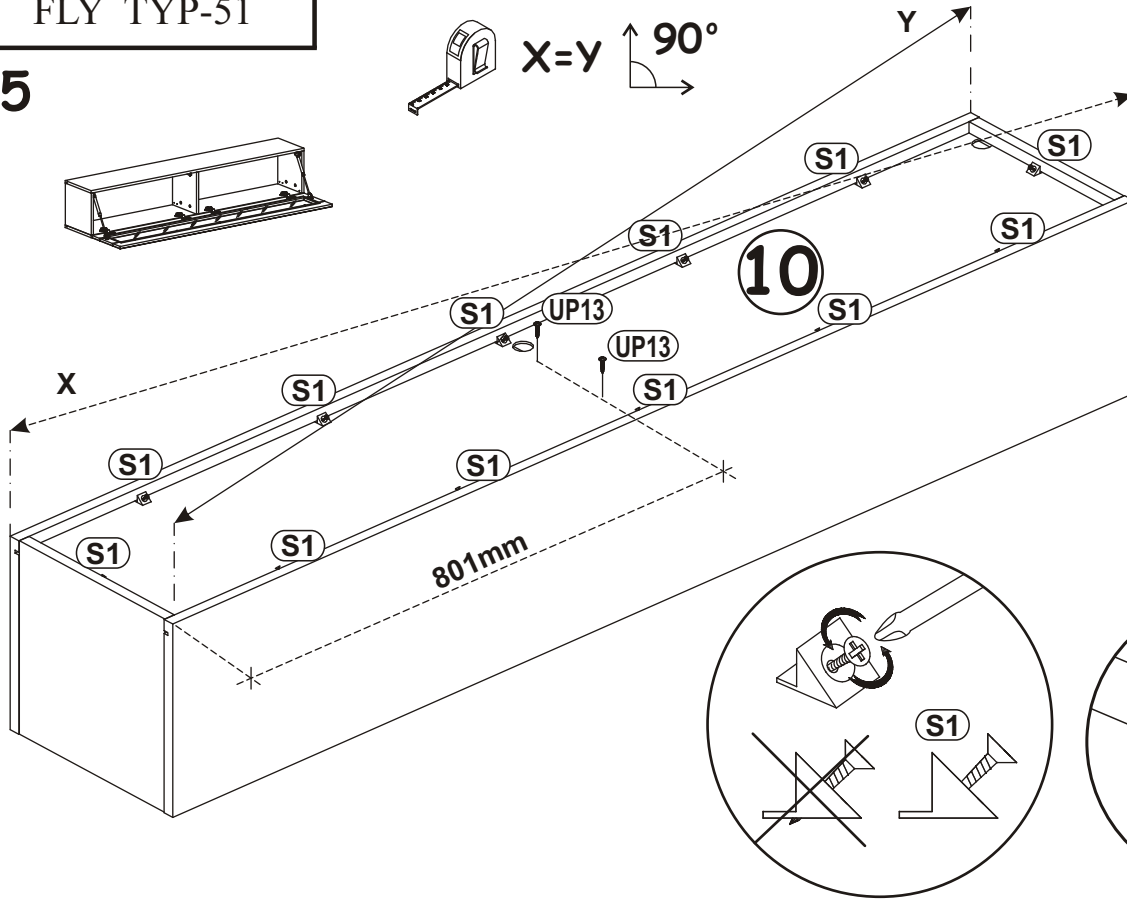

UP13	
x2	UP03x16

S1	
x12	

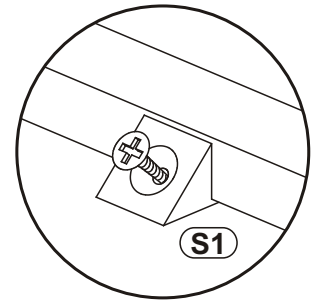
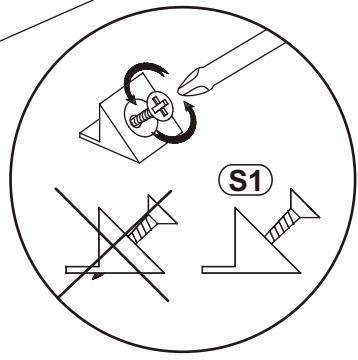
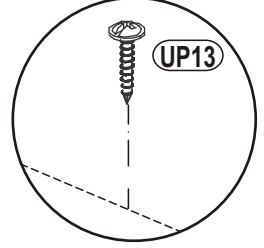

6

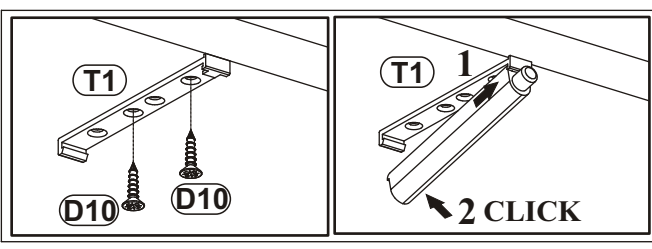

ZR1	
x2	

D6	
x4	US03,5x30

T1	
x1	

D10	
x2	US03,5x13

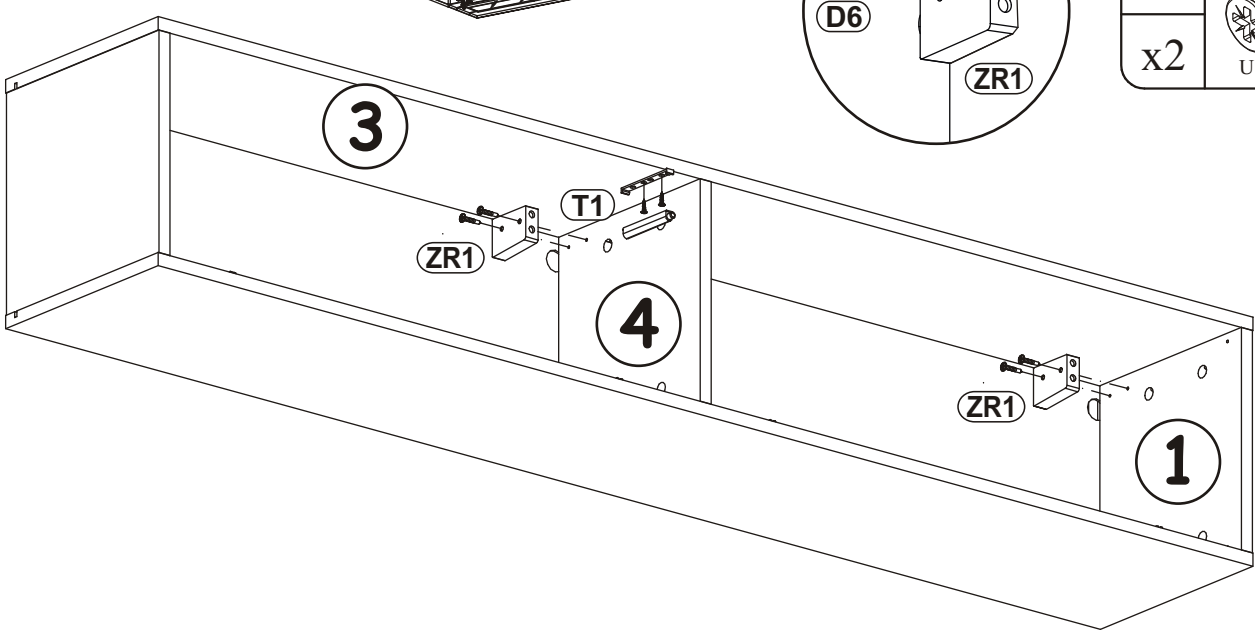
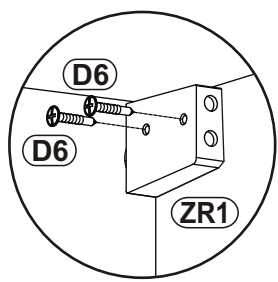
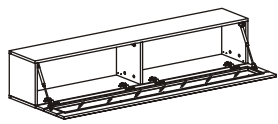

FLY TYP-51

7

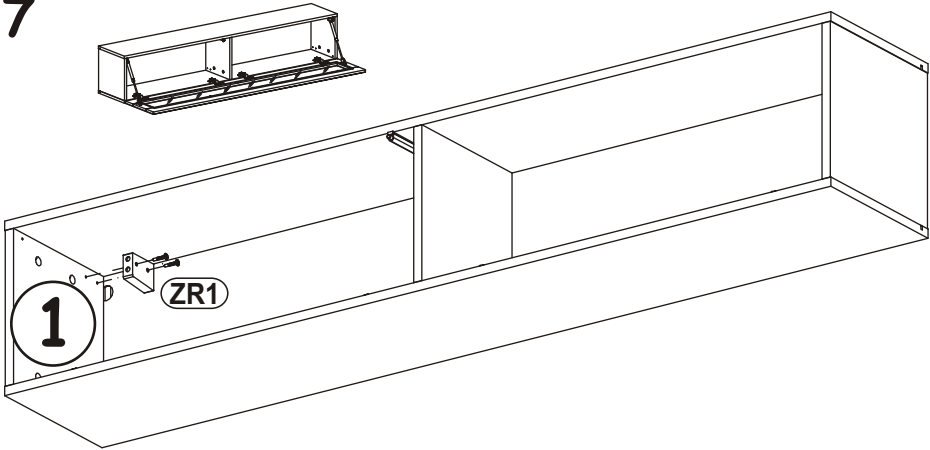

ZR1		D6	
x1		x2	USØ3,5x30

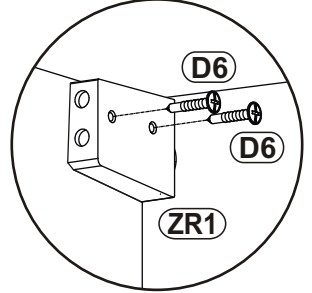

8

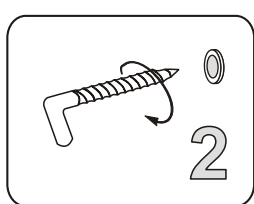
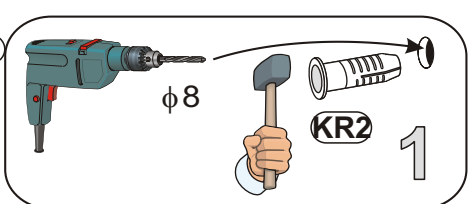
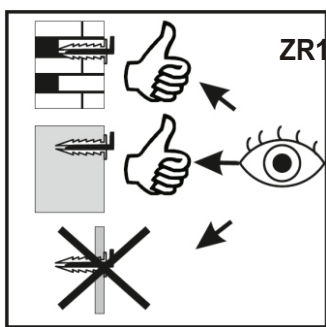

KR2	
x3	

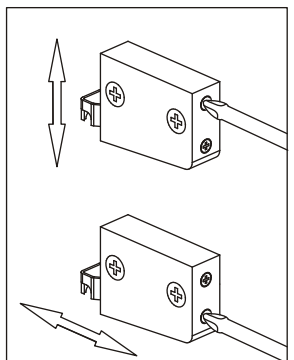
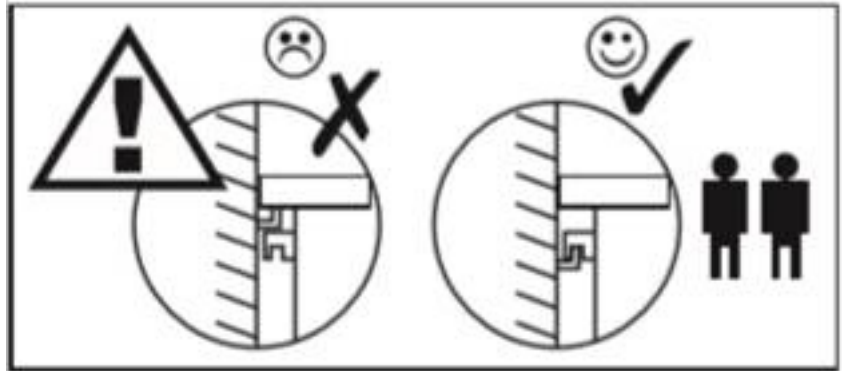
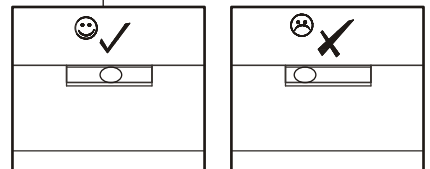
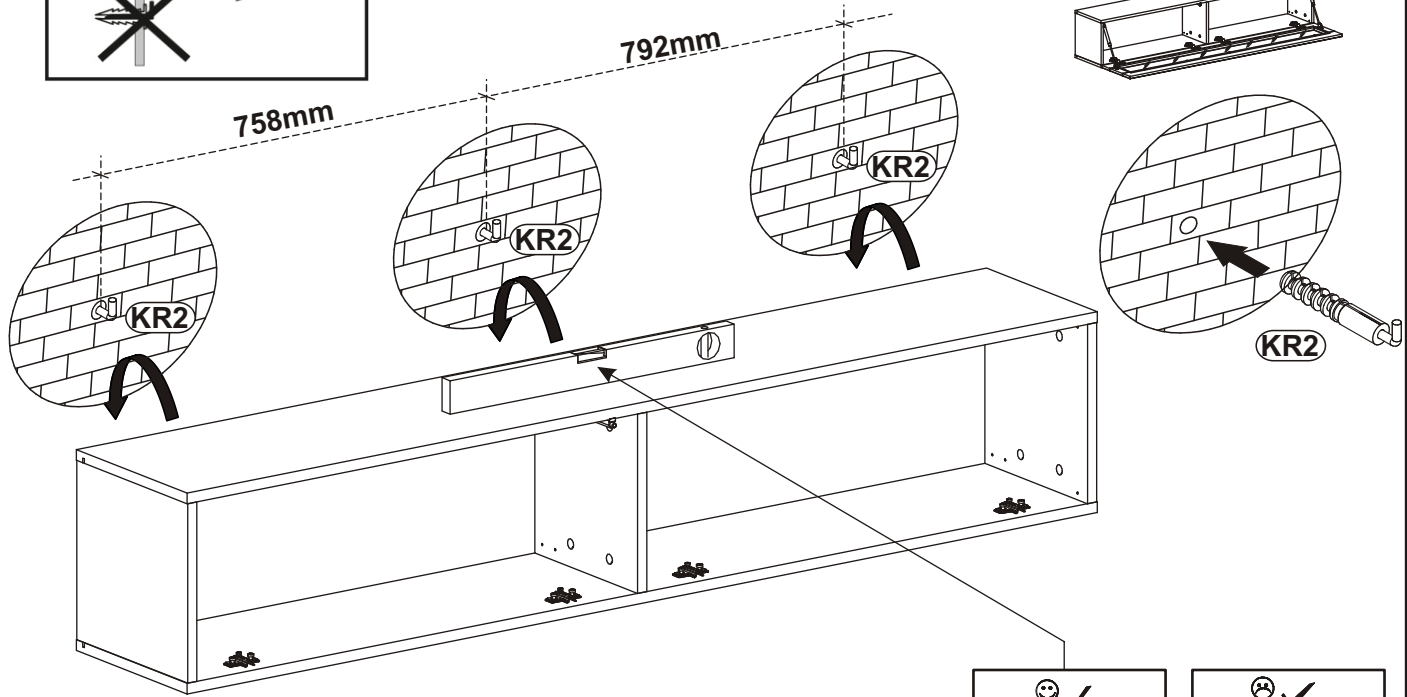



FLY TYP-51

9

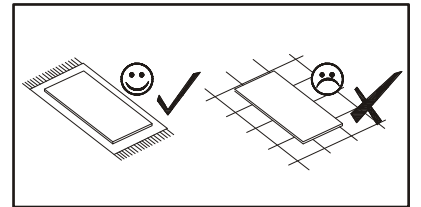
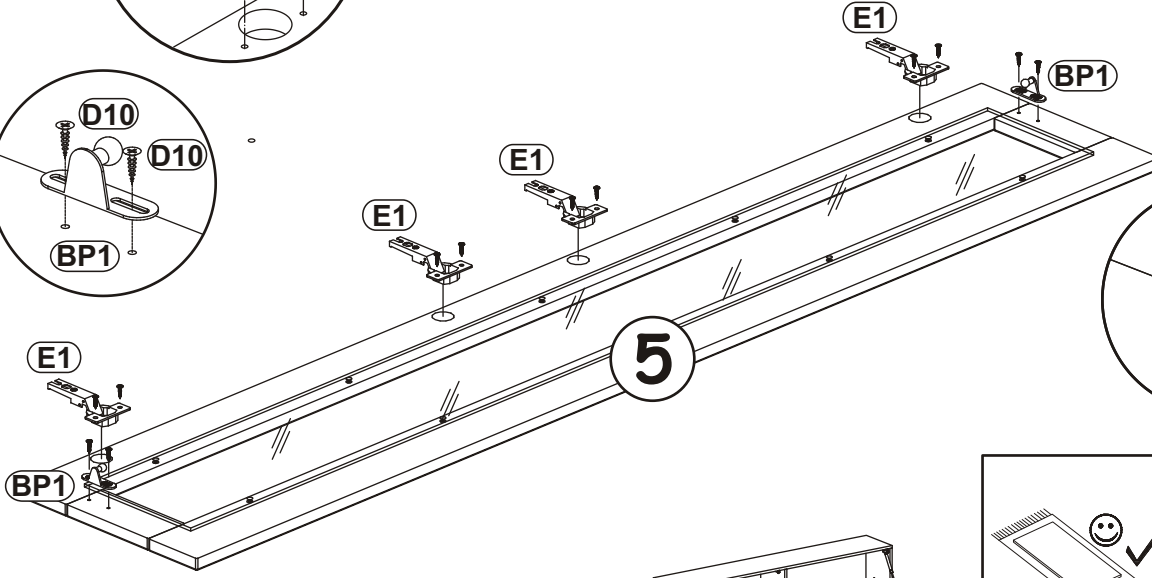
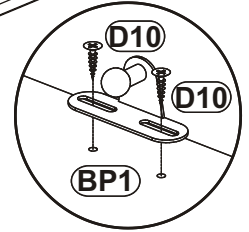
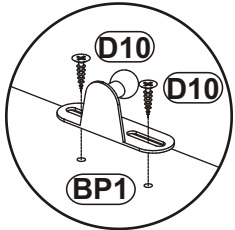
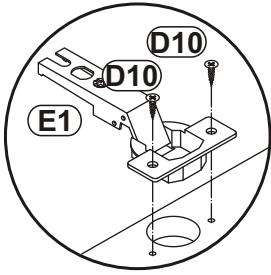
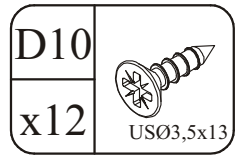
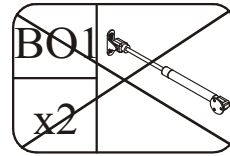
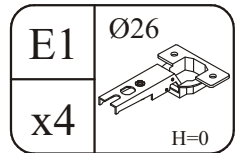
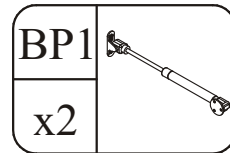
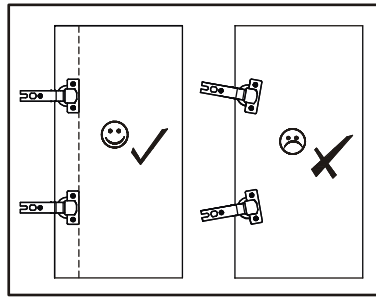

10

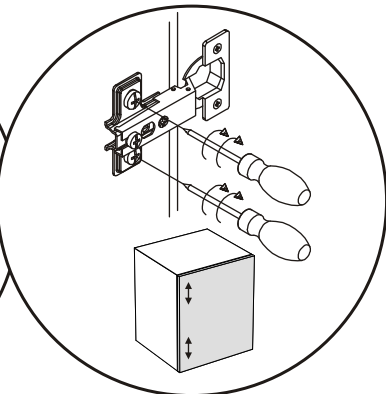
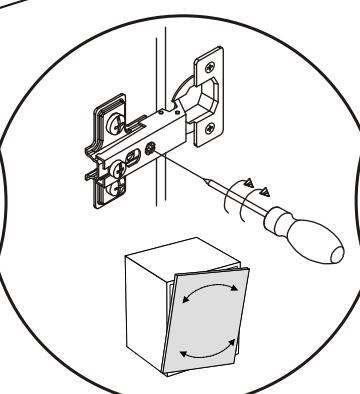
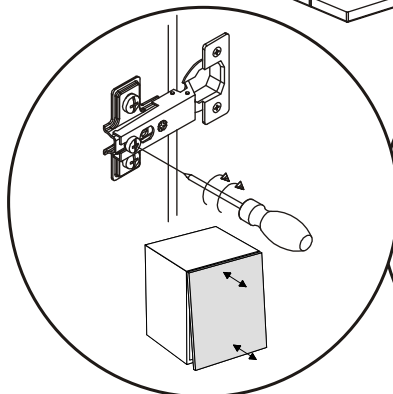
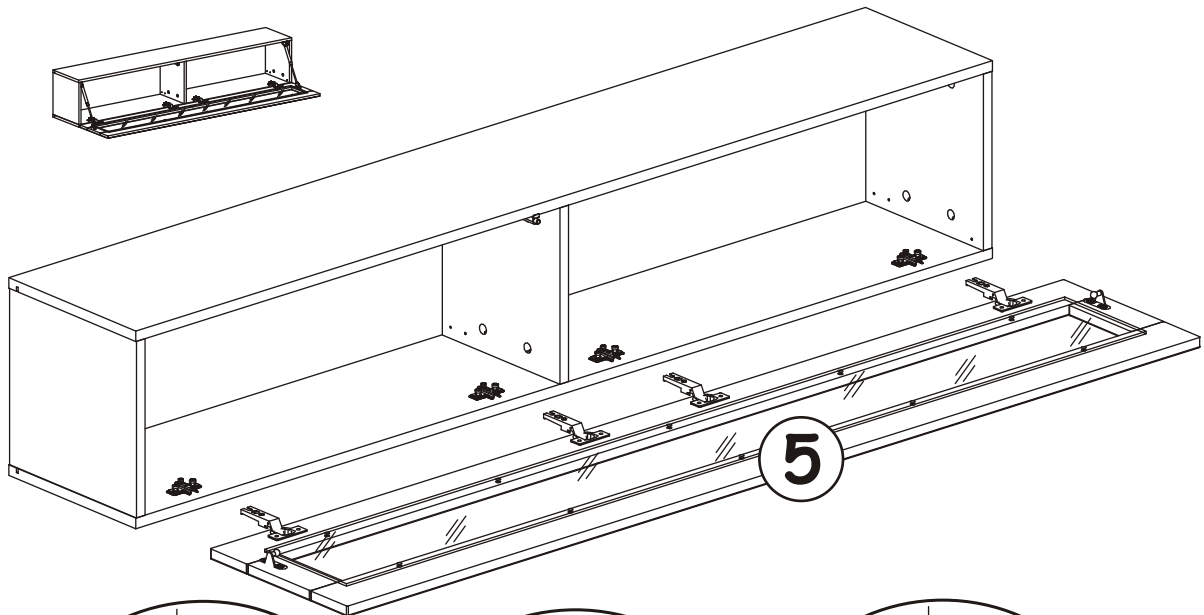

11

D10	
x6	

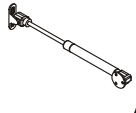
BP1	
x2	

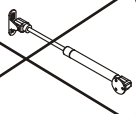
<del>BO1</del>	<del></del>
<del>x2</del>	

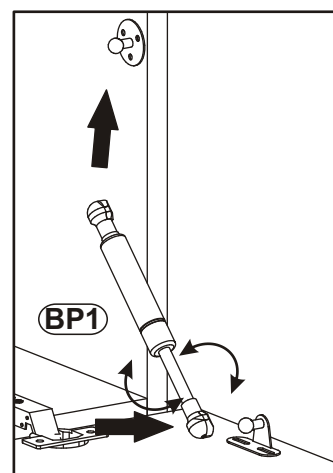
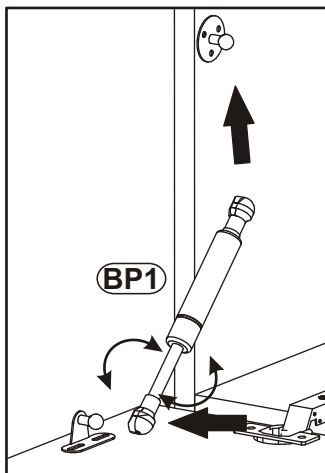
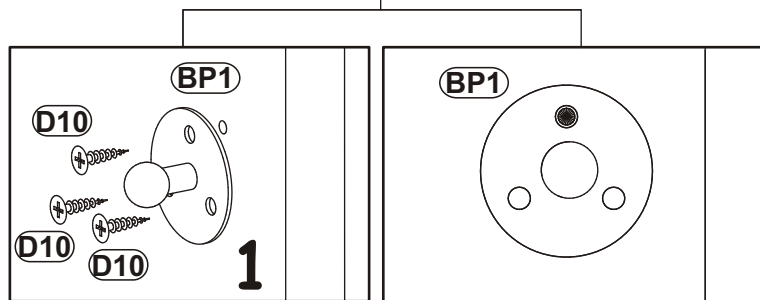
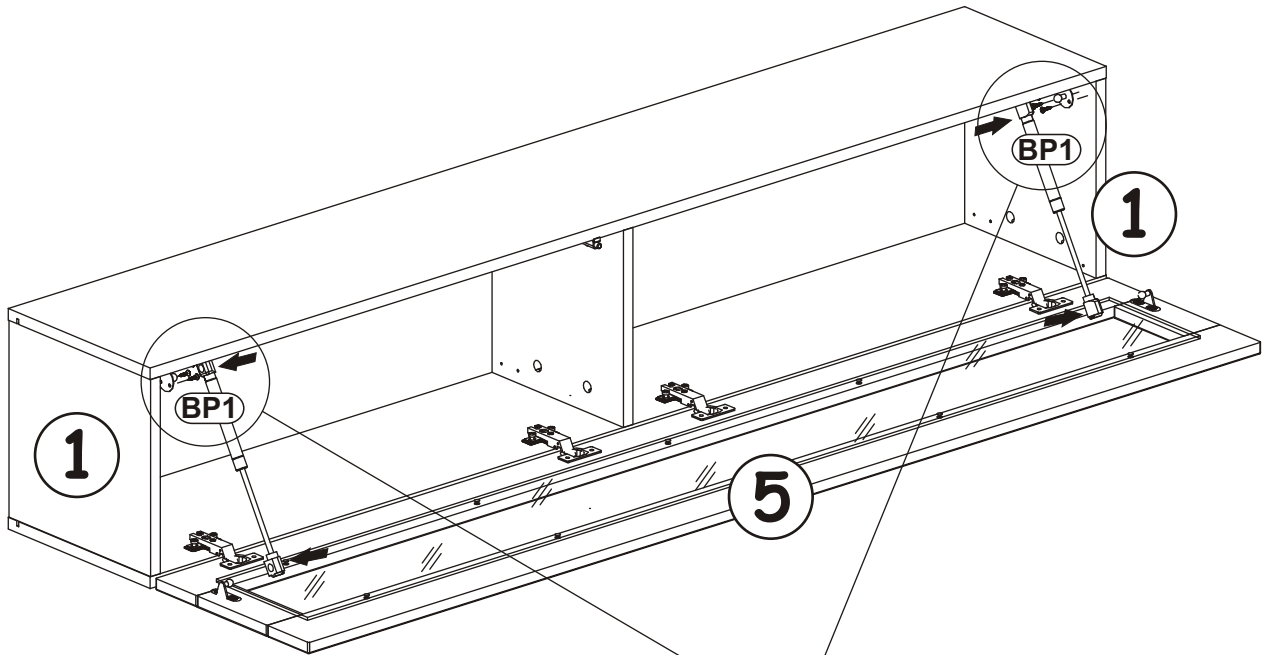
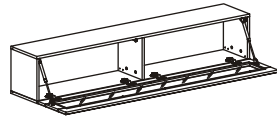

12

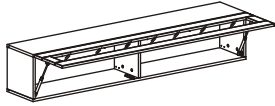

a)

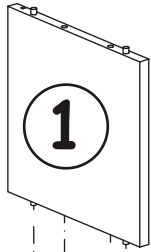

3

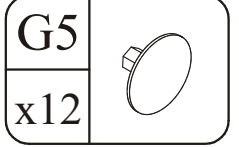

b) ↓

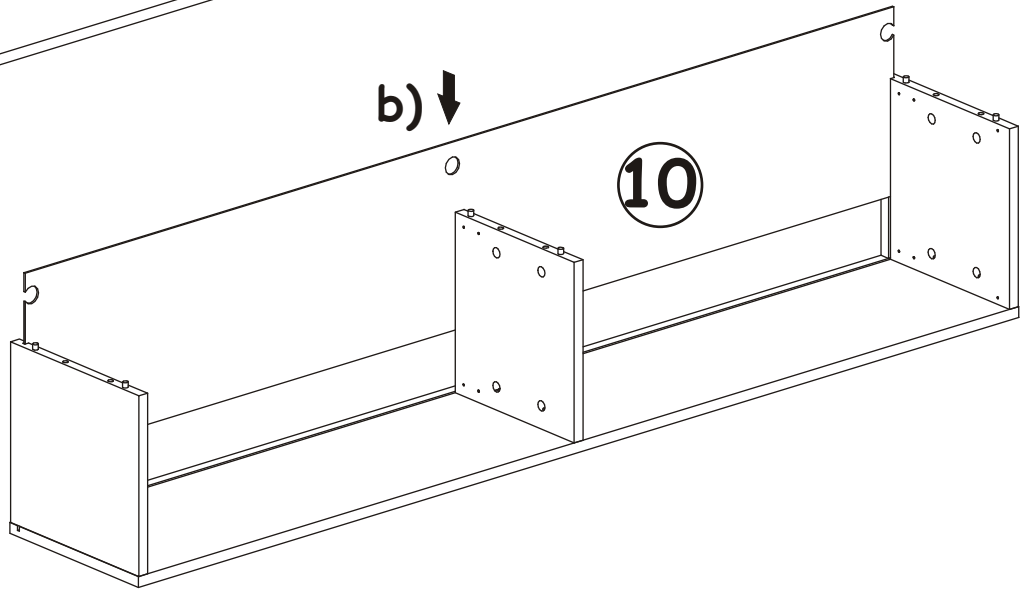
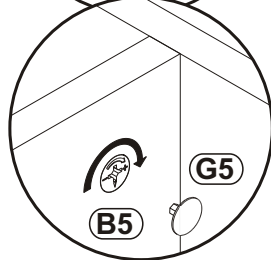
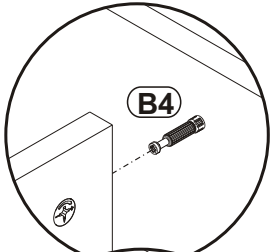

10

c)

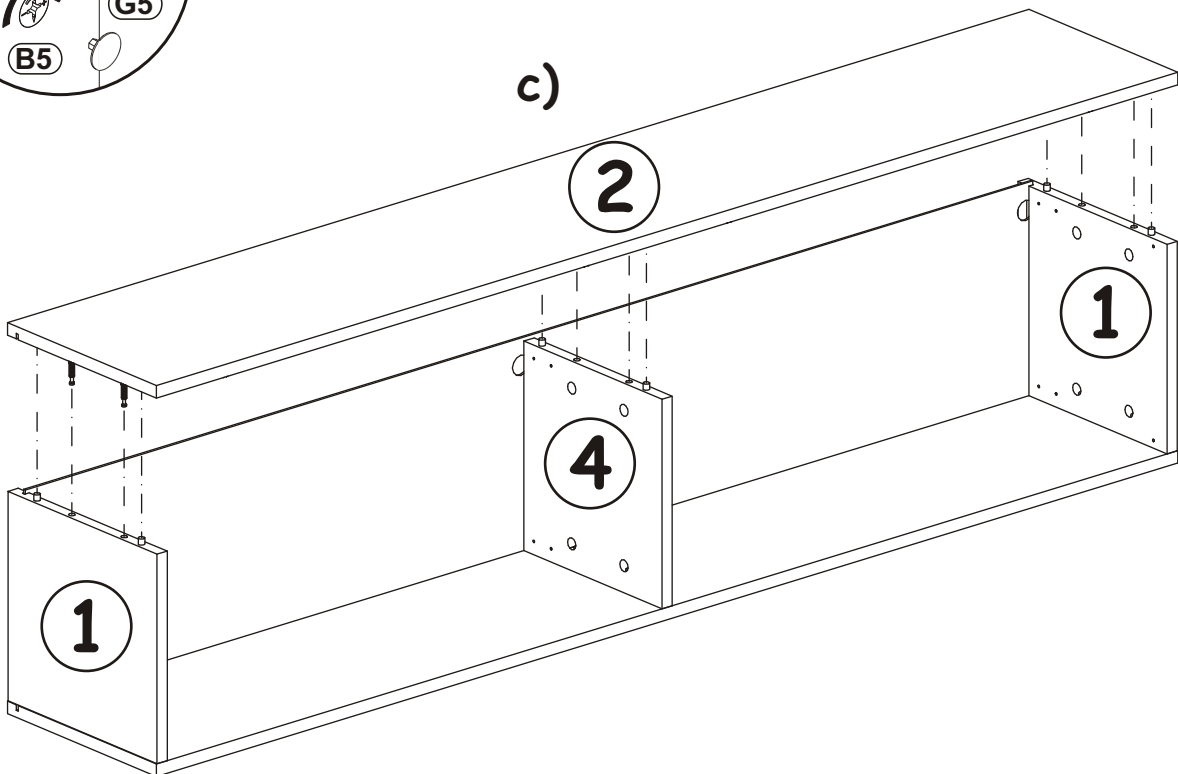

2

1

4

1

FLY TYP-51

13

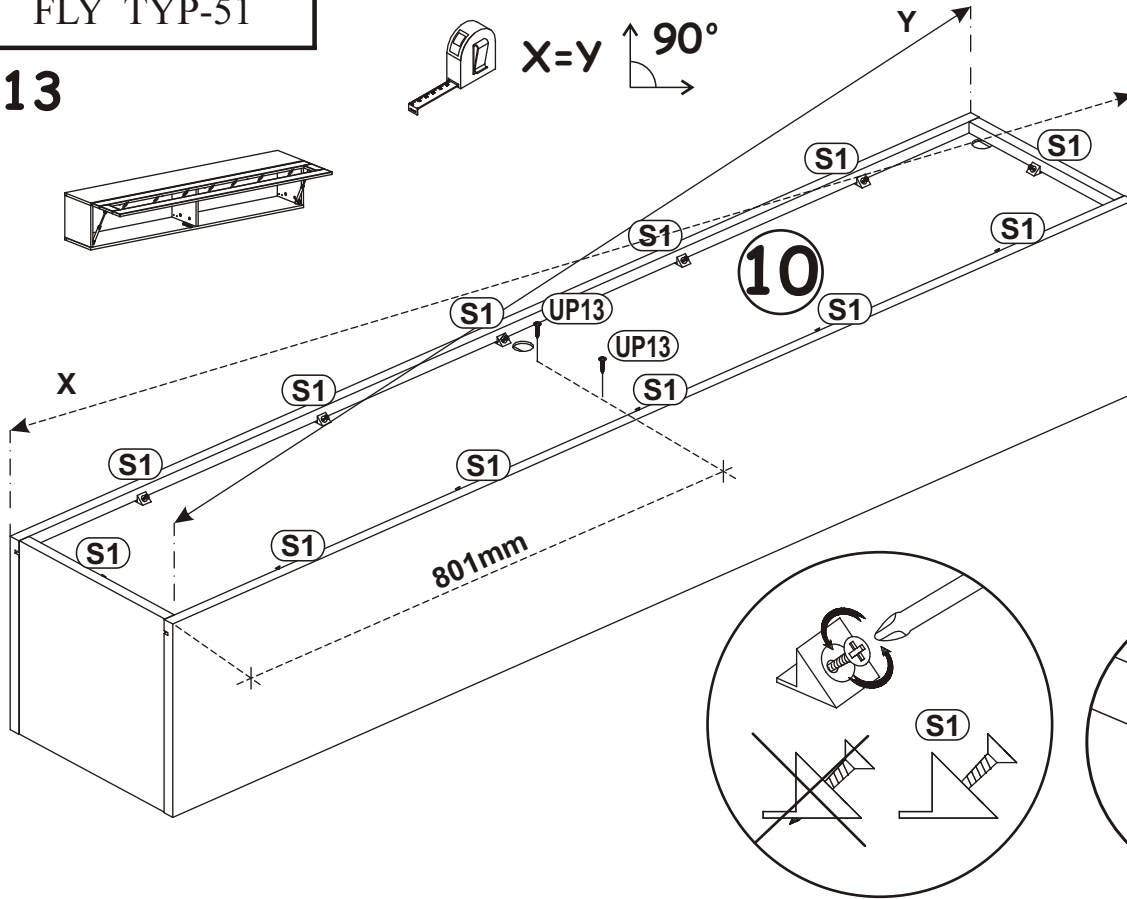

UP13	
x2	UPØ3x16

S1	
x12	

	UP13
--	------

	S1
--	----

	S1
--	----

14

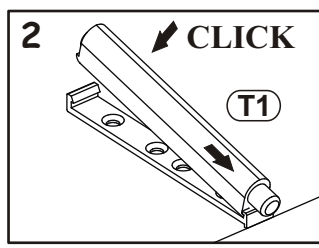
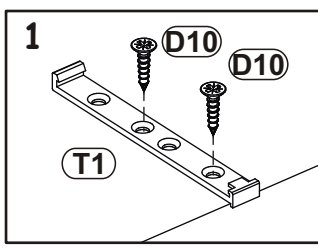

ZR1	
x2	

D6	
x4	USØ3,5x30

T1	
x1	

D10	
x2	USØ3,5x13

	D6
	ZR1

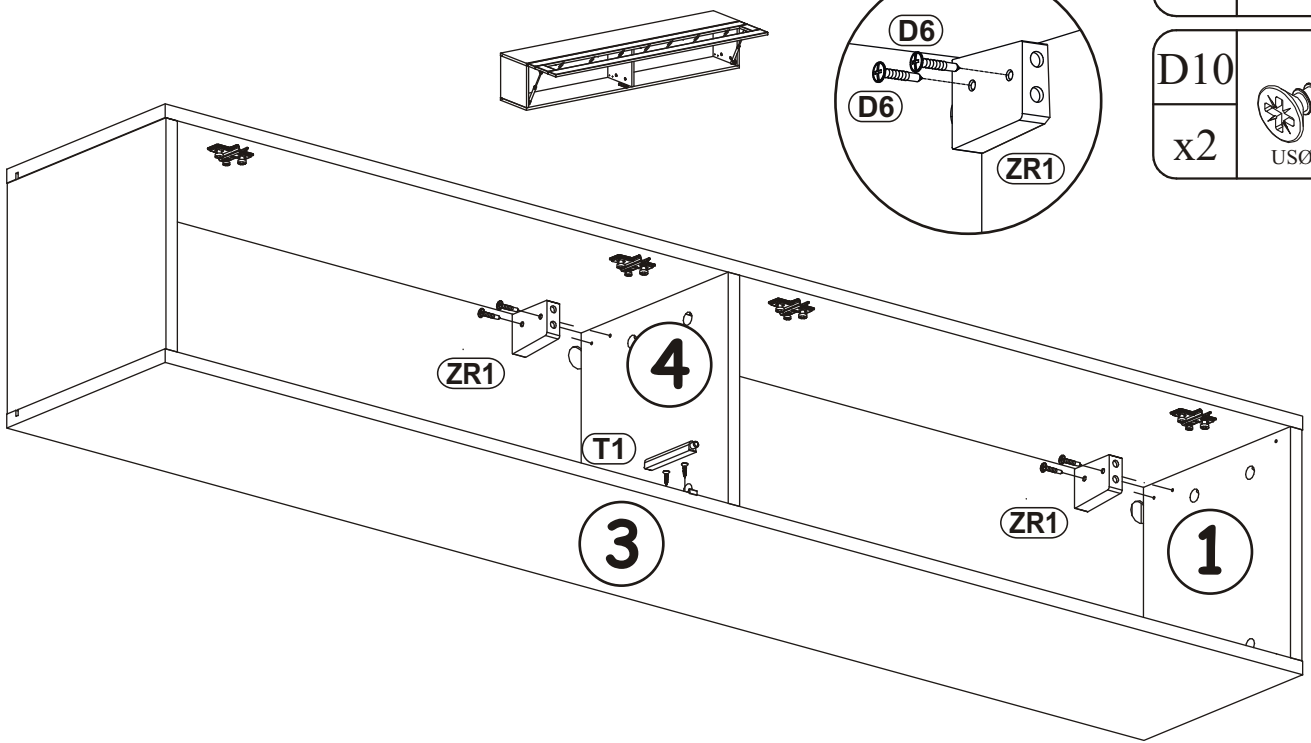

FLY TYP-51

15

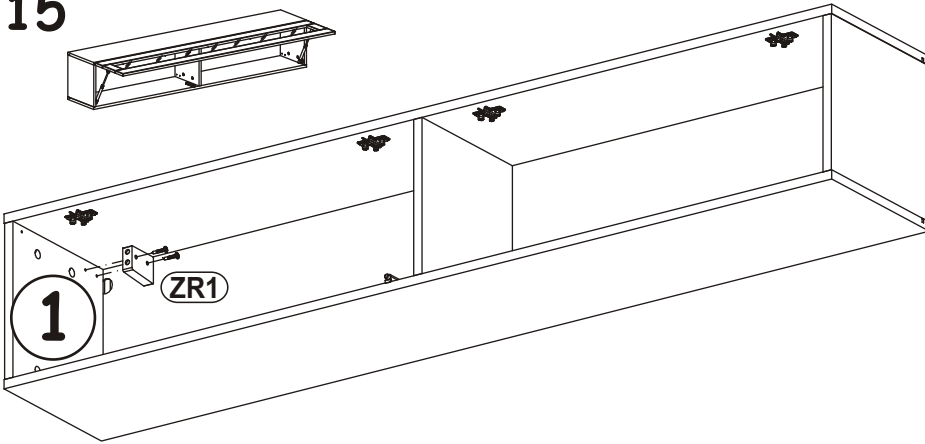

ZR1		D6	
x1		x2	USØ3,5x30

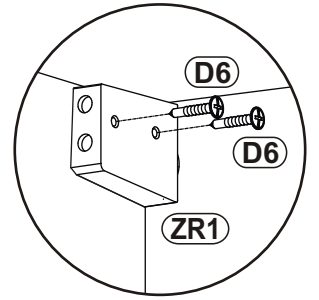

16

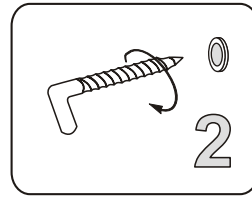
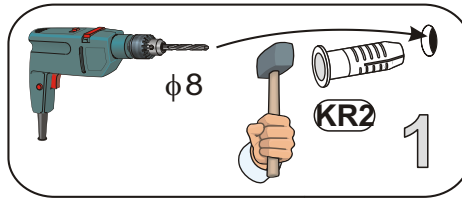
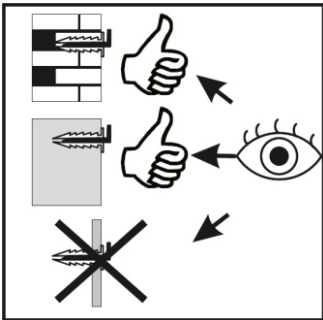

KR2	
x3	

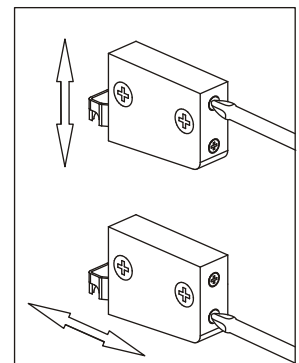
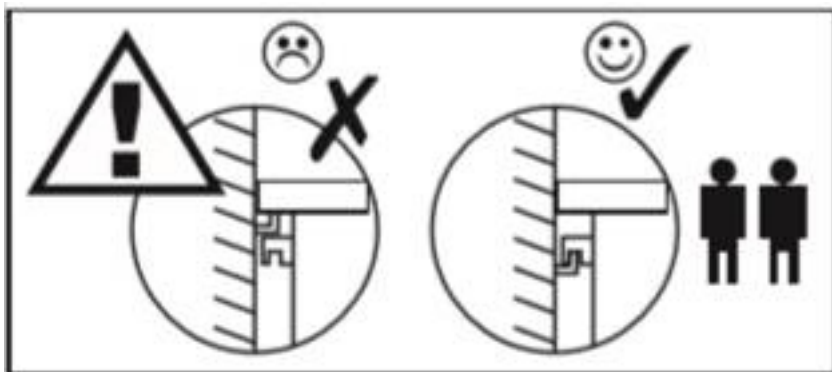
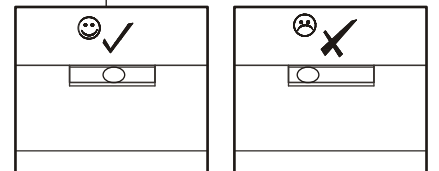
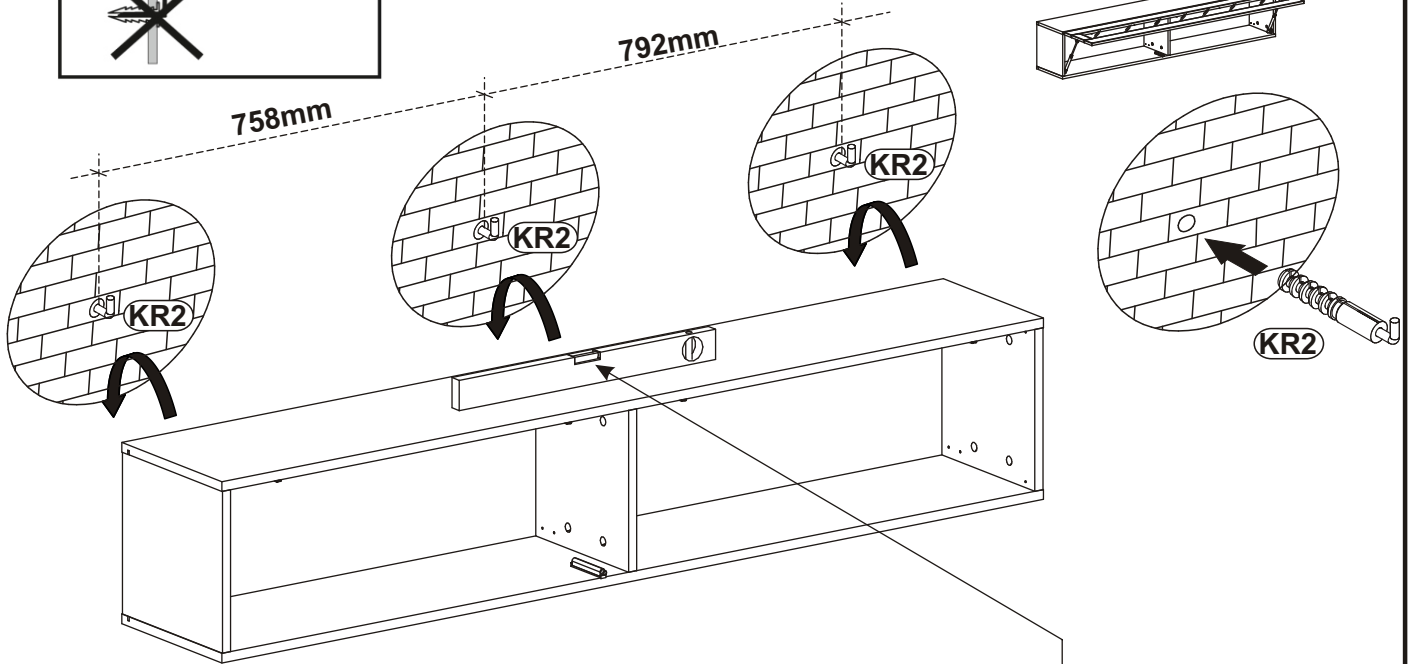
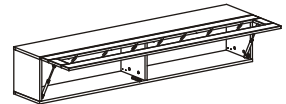

17

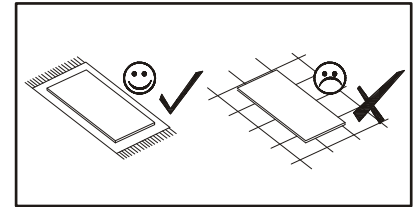
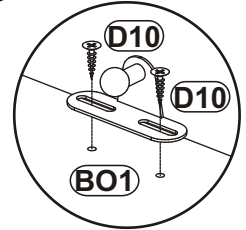
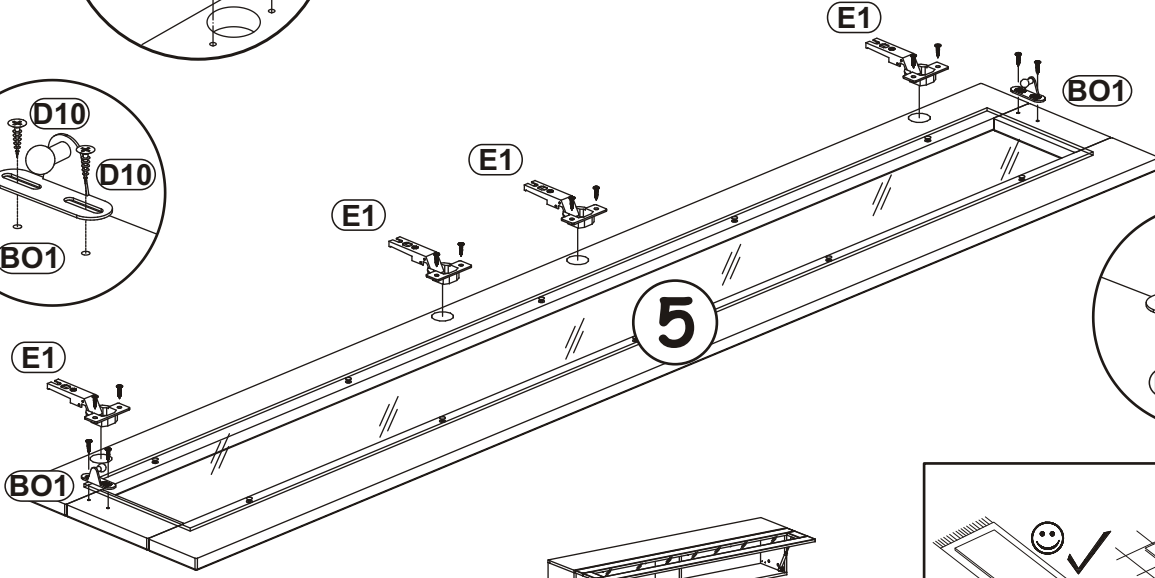
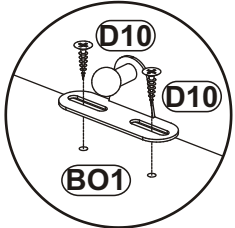
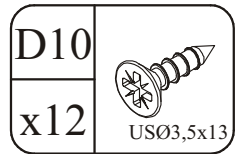
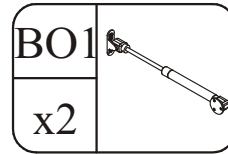
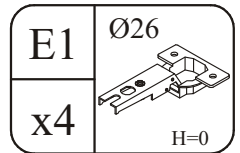
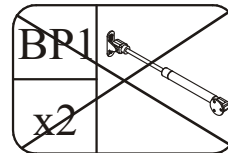
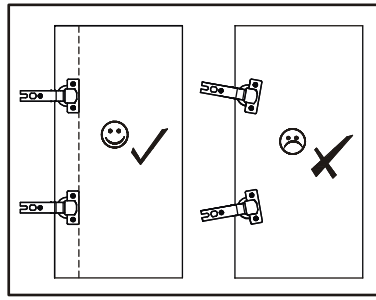
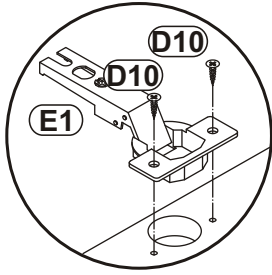

18

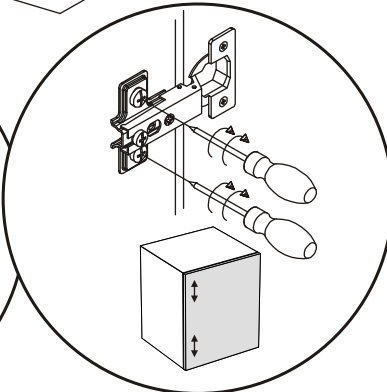
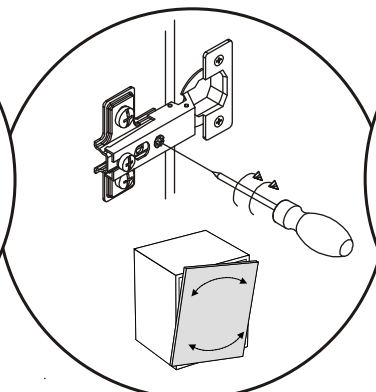
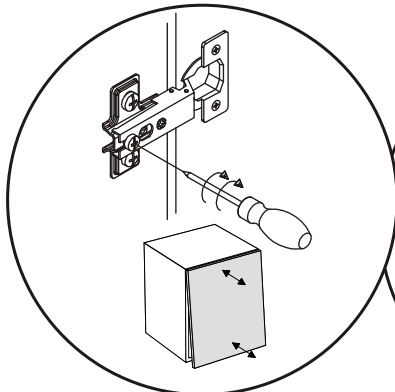
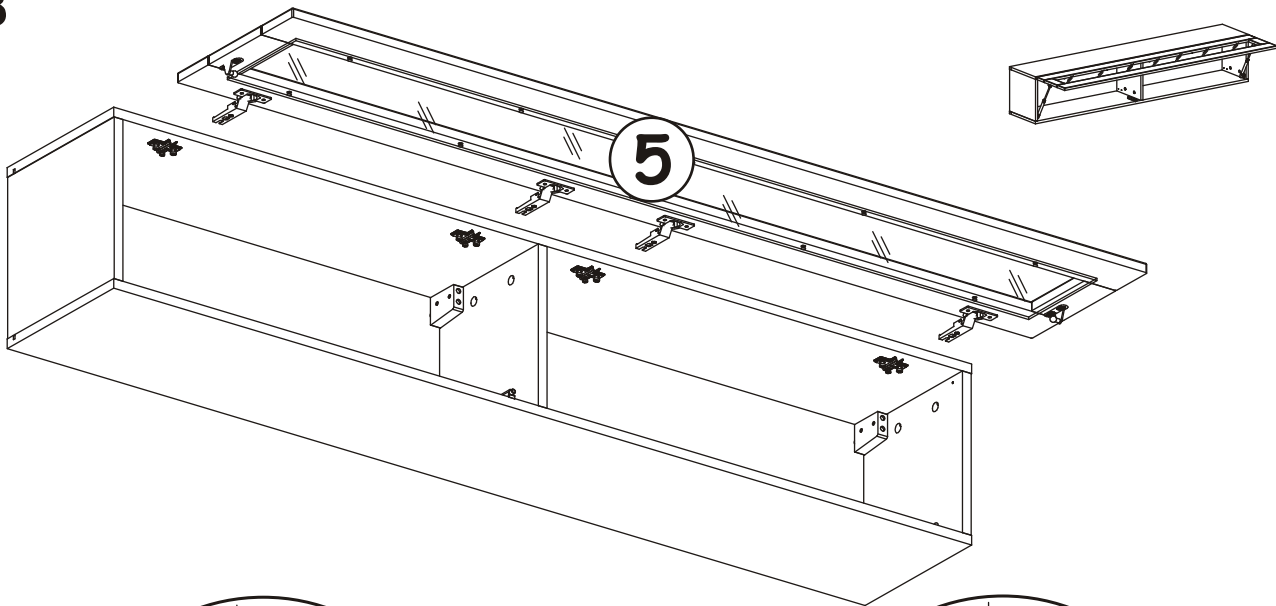

FLY TYP-51

